



New Project Proposal: SFF-TA-1048

Compression Mount High-Speed Cable Interconnect

Presented: 2026-04-17

Presenter: Raymond Law [LOTES]

Supporters: Jeff Wolford [HPE]
Mike Gregoire [Dell]
Trent Johnson [IBM]
Raymond Law [LOTES]

New Project Proposal: SFF-TA-1048 Compression Mount High-Speed Cable Interconnect

- This specification defines the mechanical specifications and general performance requirements for a Compression Mount Cable Interconnect System that is designed for high-speed serial applications. Formfactors include vertical and right-angle receptacles and plugs for high speed (up to 256G) internal high-speed applications
- Editor(s): Raymond Law [LOTES]
- Supporters:
 1. HPE
 2. Dell
 3. IBM
 4. LOTES

New Project Proposal: SFF-TA-1048 Compression Mount High-Speed Cable Interconnect

- Key Features of Compression Mount Cable/Connector System
 - Right angle exit and straight exit cable
 - Low profile: 8.0mm mated height for right-angle
 - Pitch: 0.5mm within pair, 2.0mm x 1.8mm pair-to-pair
 - Support 29, 30, and 32 AWG twinax cables
 - Intent to support up to 256G data rate for PCIe and Ethernet applications
- IP Declaration (if applicable):
 - TBD

Compression Mount PrezLink Ultra

Example 2x12 Formfactor

GND shielding



Signal pairs

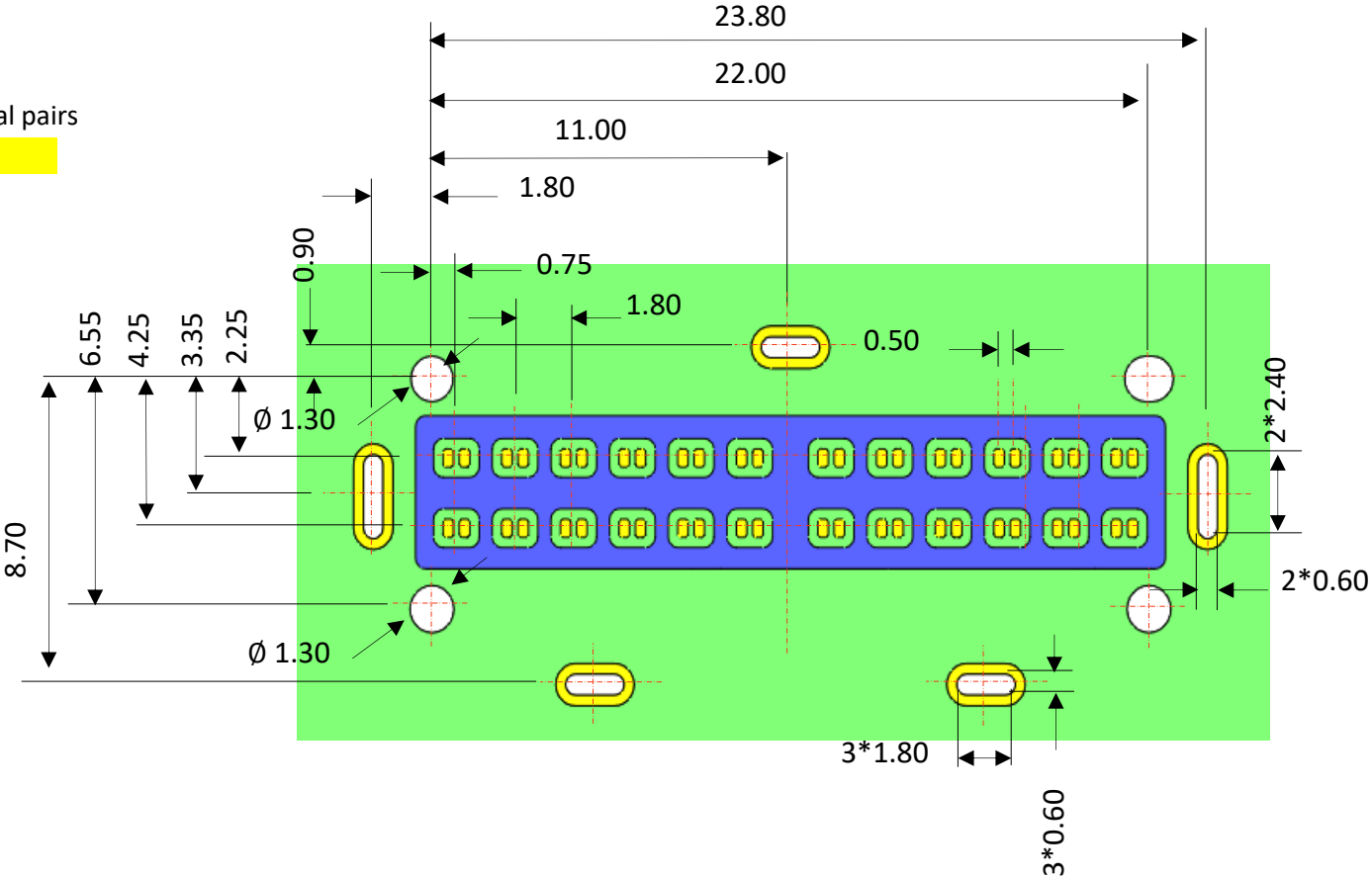

Compression Mount PrezLink Ultra – Right-Angle

Example 2x12 Formfactor

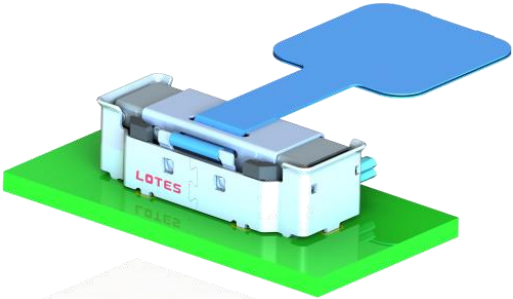
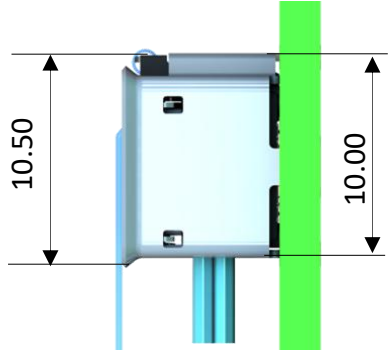
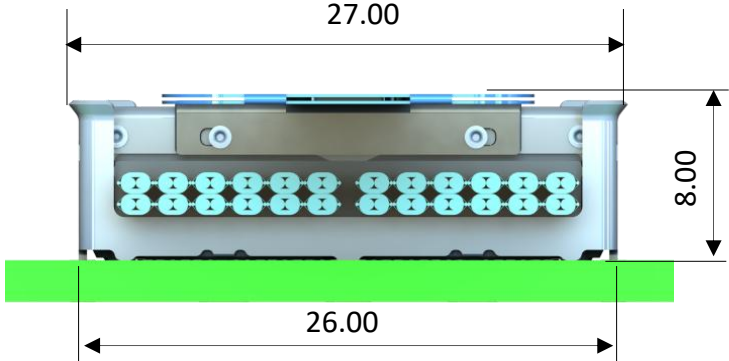
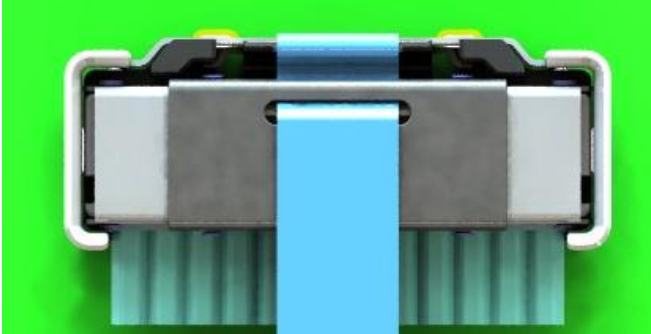
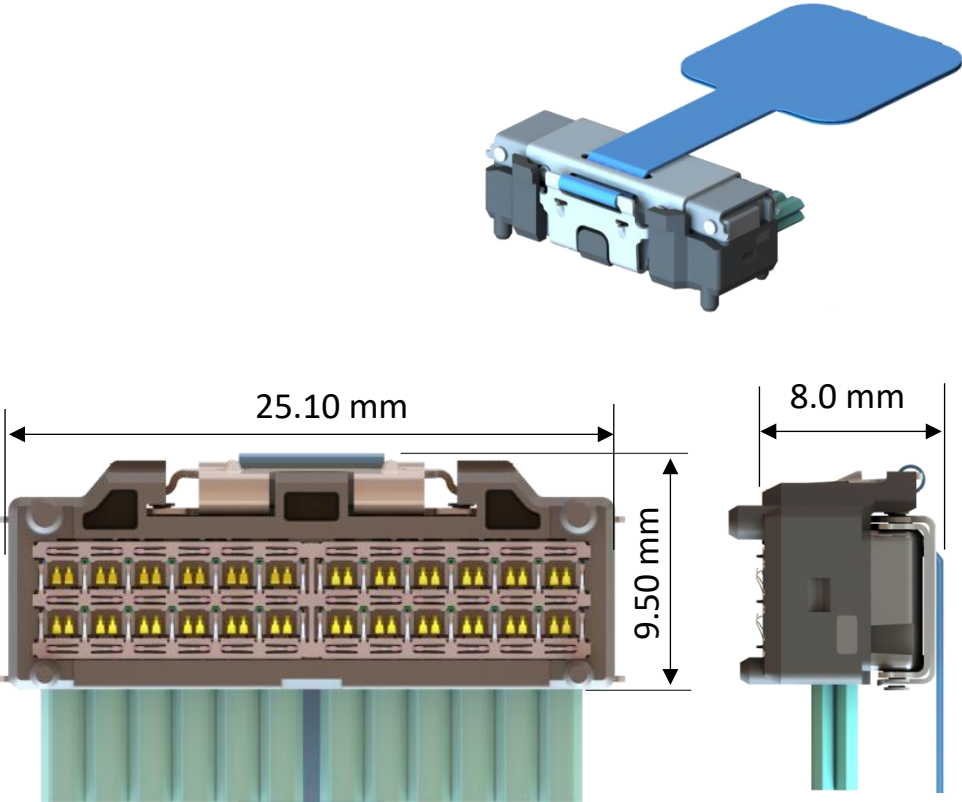

Compression Mount PrezLink Ultra – RA Mated Connector

Example 2x12 Formfactor

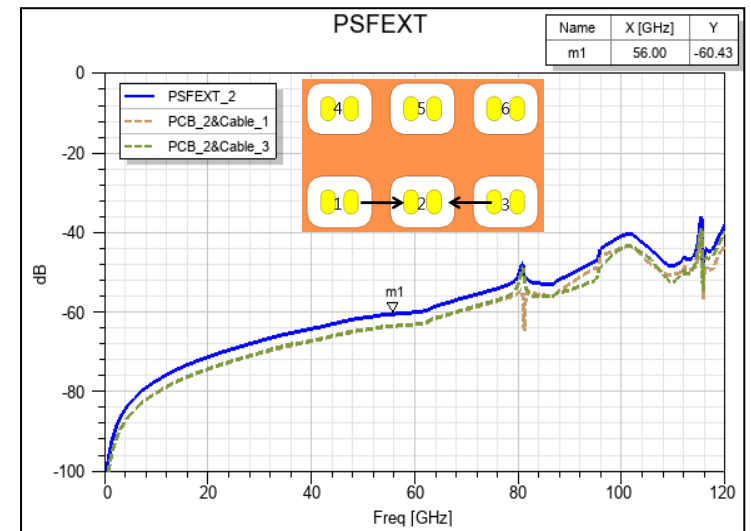
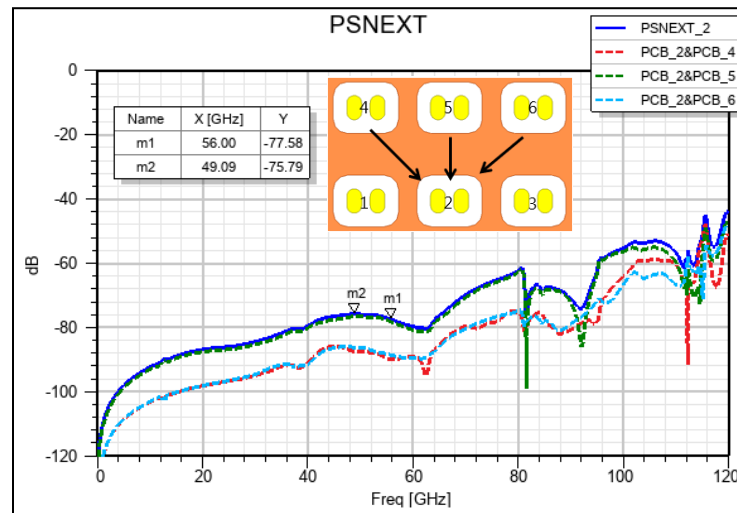
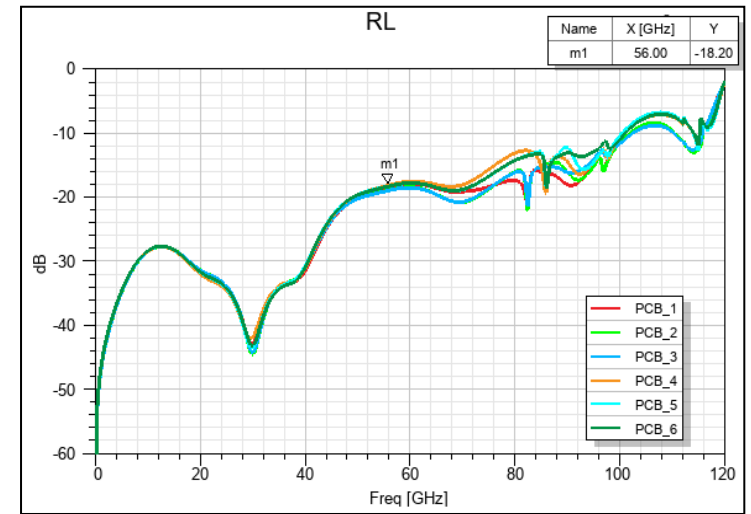
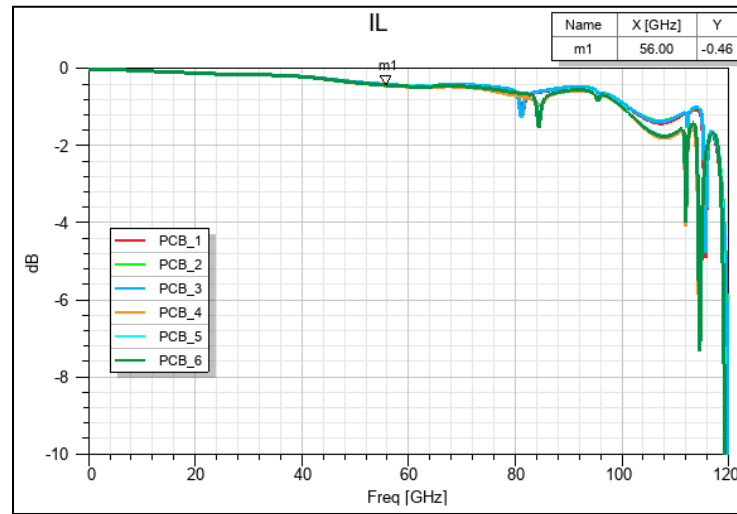
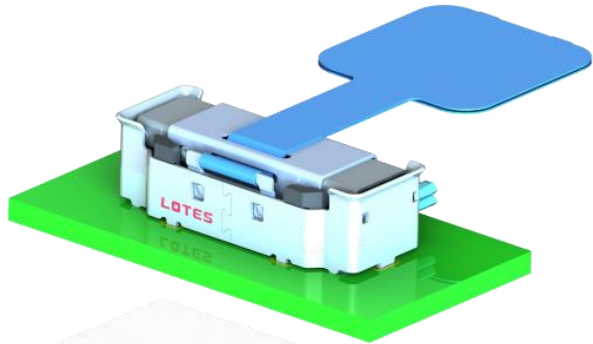

Compression Mount PrezLink Ultra – RA Cable Assembly

Example 2x12 Formfactor

- 500mm 30 AWG cable

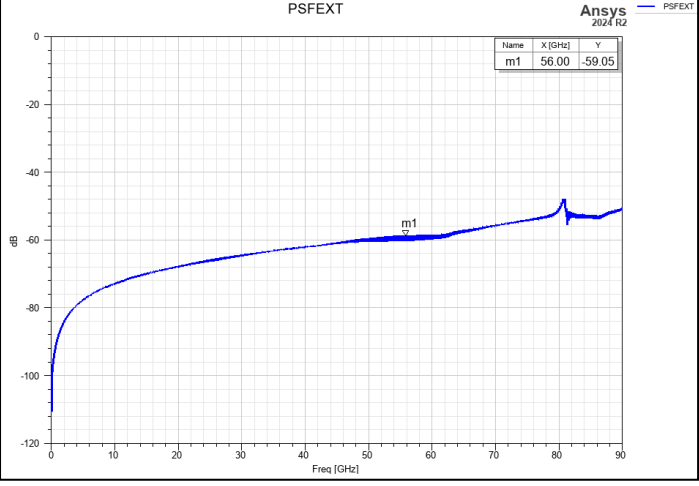
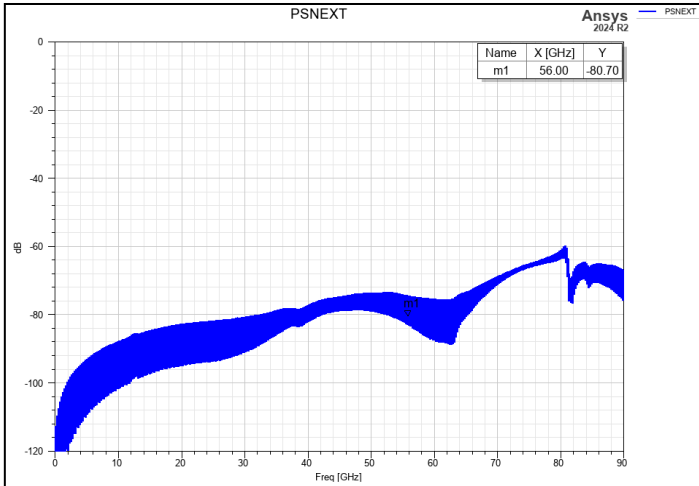
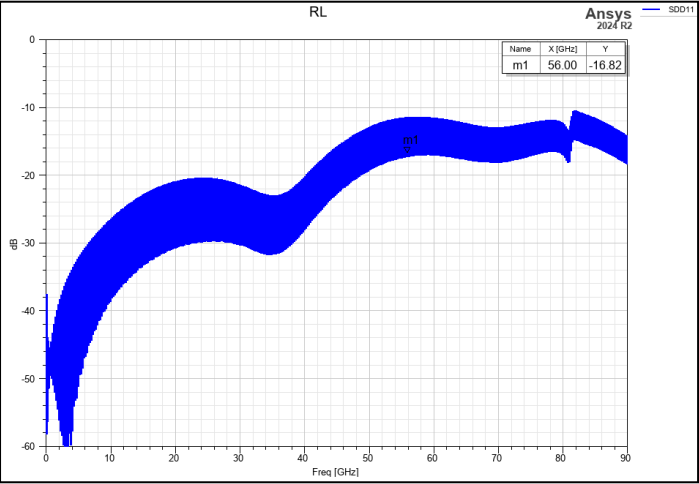
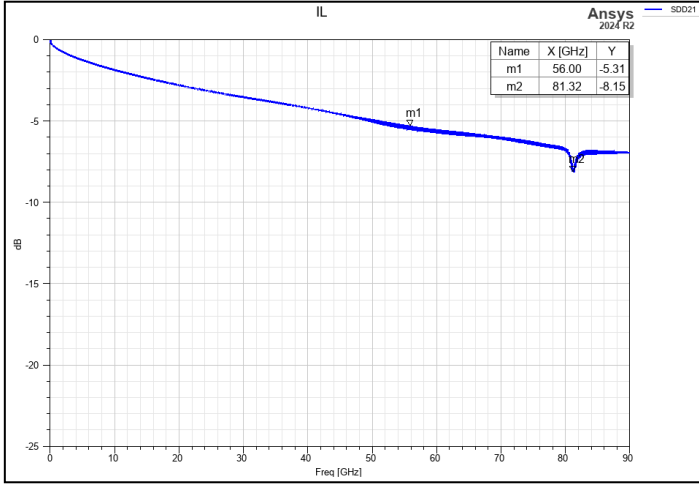
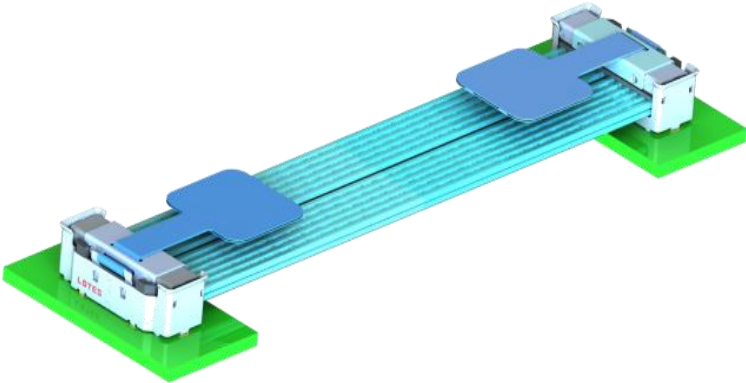

Compression Mount PrezLink Ultra – Measured RA Cable Assembly

Example 2x12 Formfactor

- 500mm 30 AWG cable
- POC sample

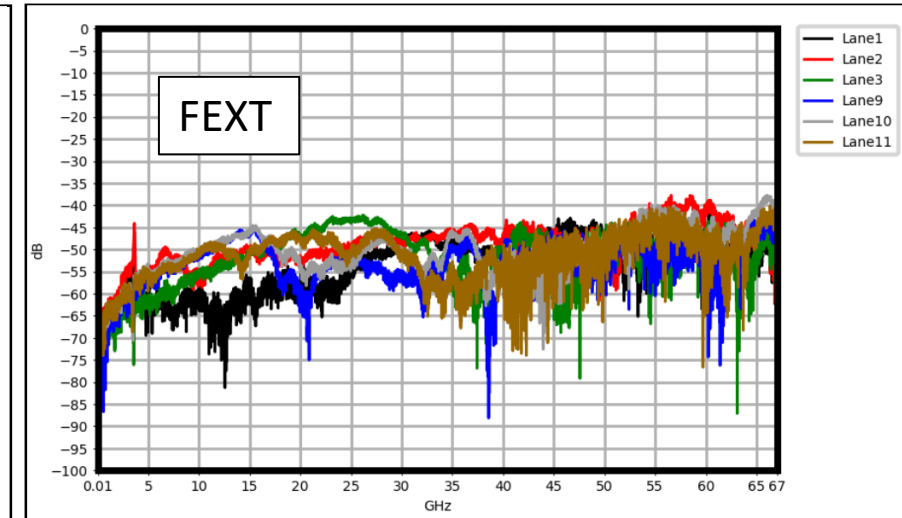
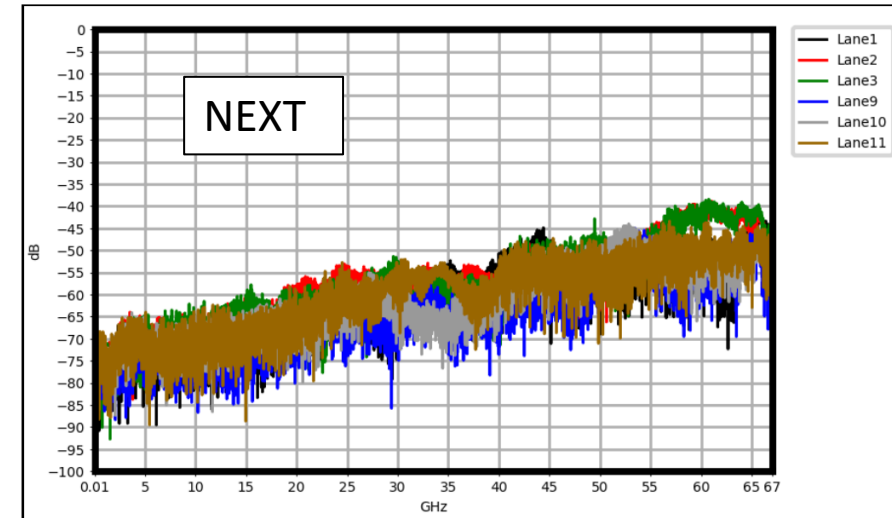
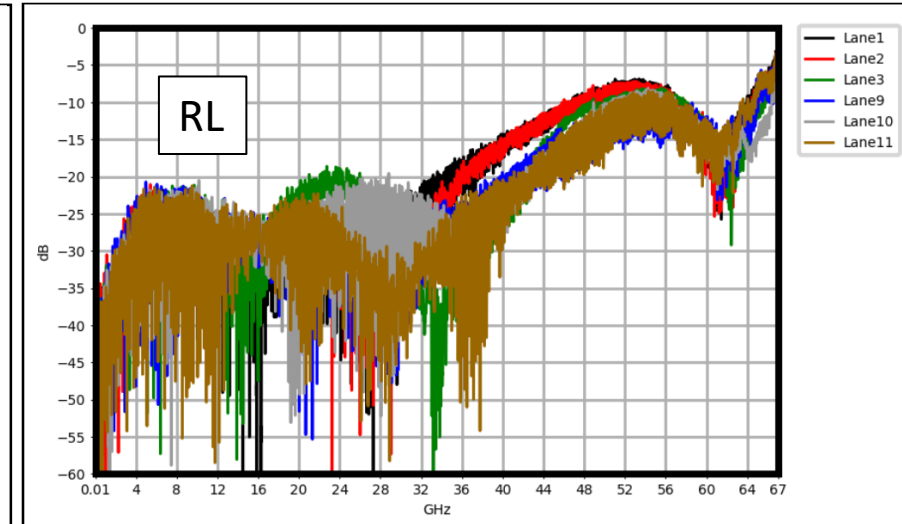
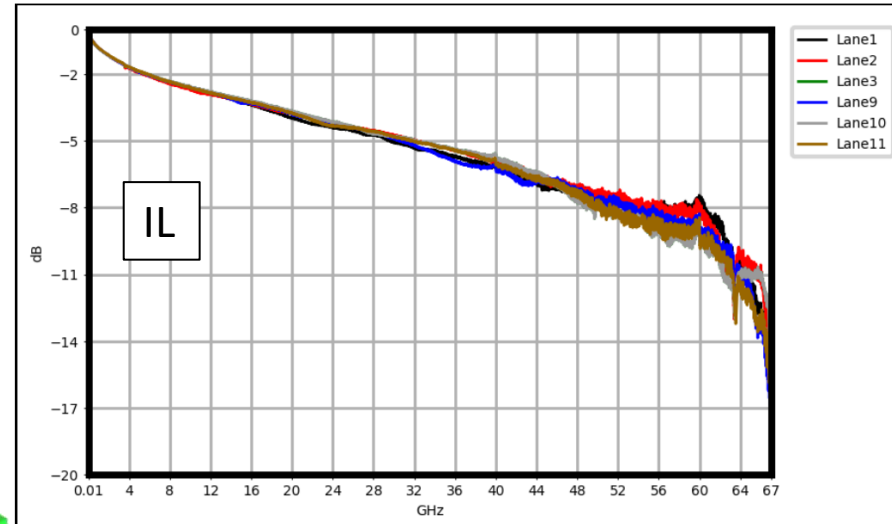
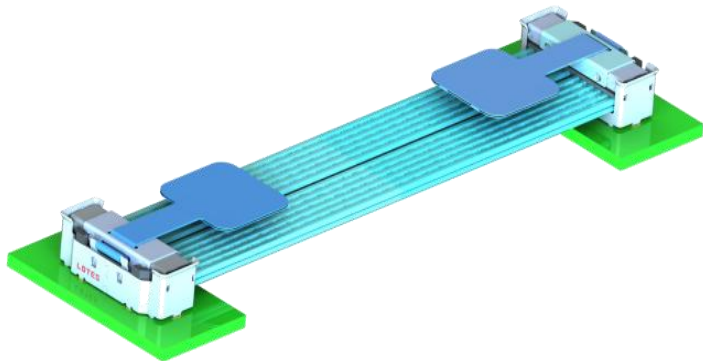

Compression Mount PrezLink Ultra – Vertical

Example 2x12 Formfactor

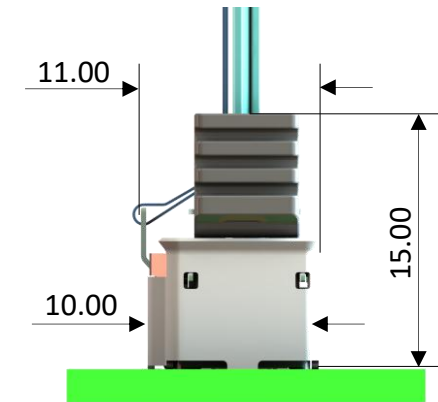
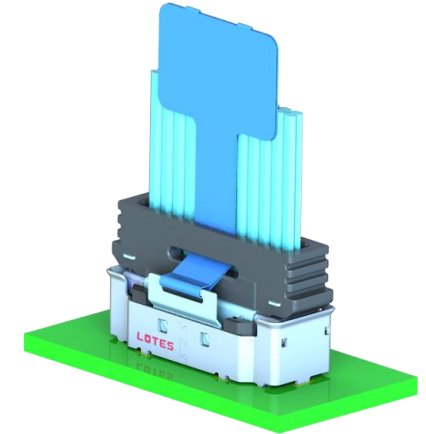
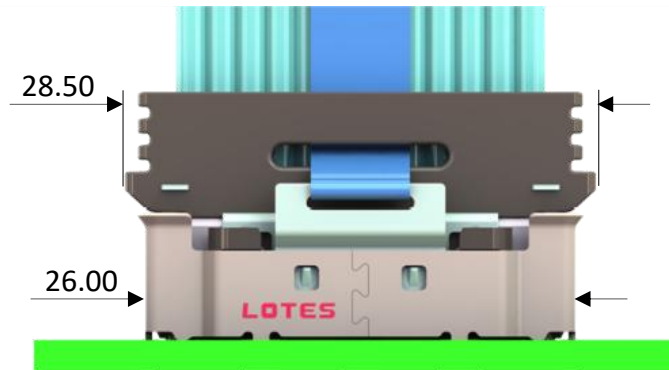
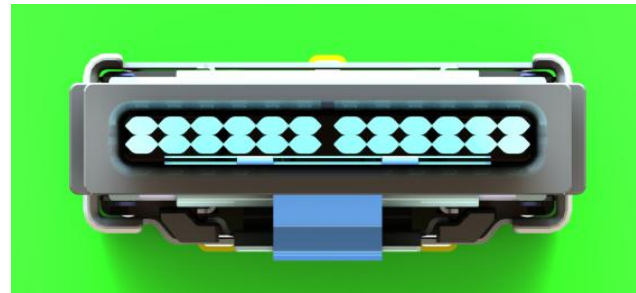
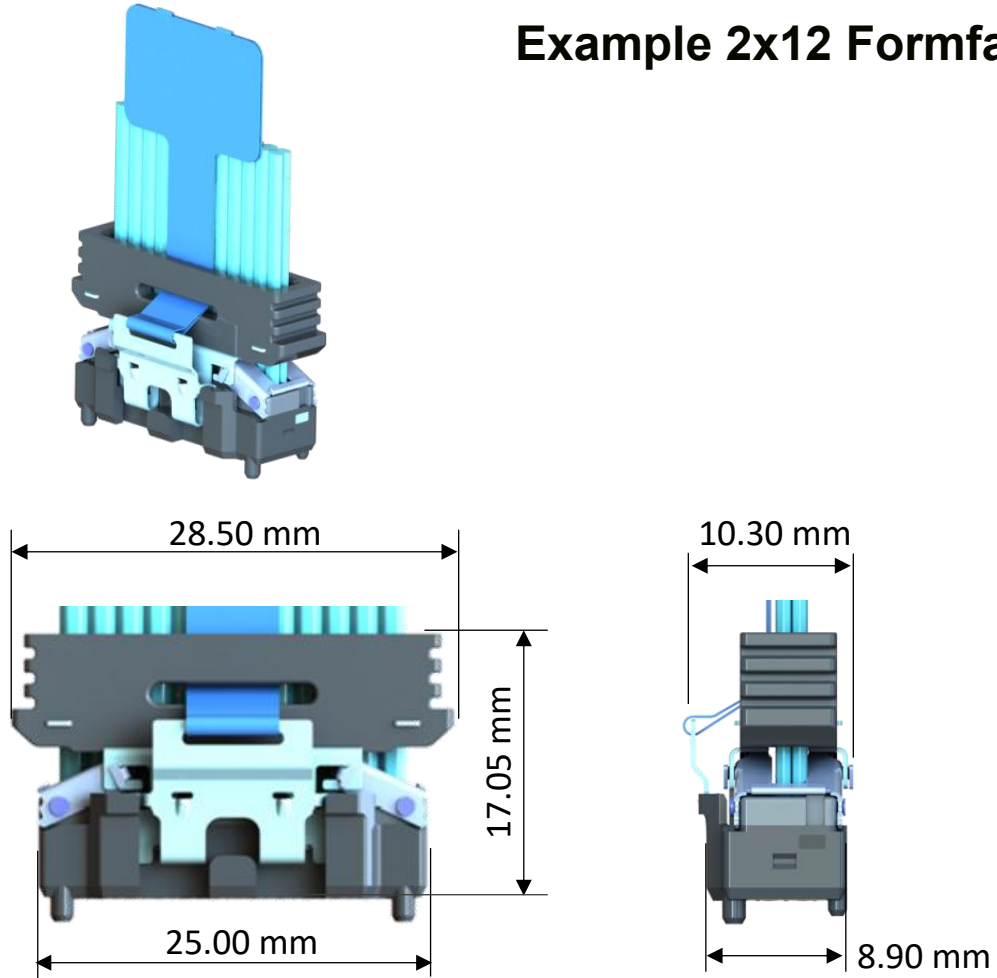

Compression Mount PrezLink Ultra – Vertical Mated Connector

Example 2x12 Formfactor

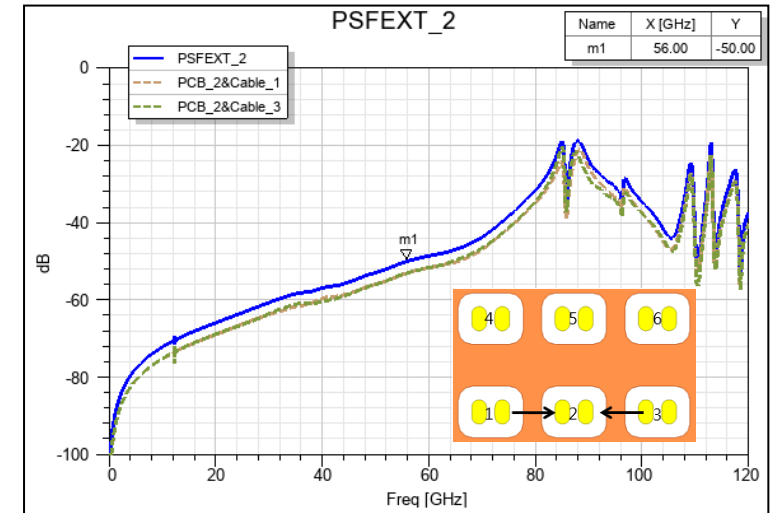
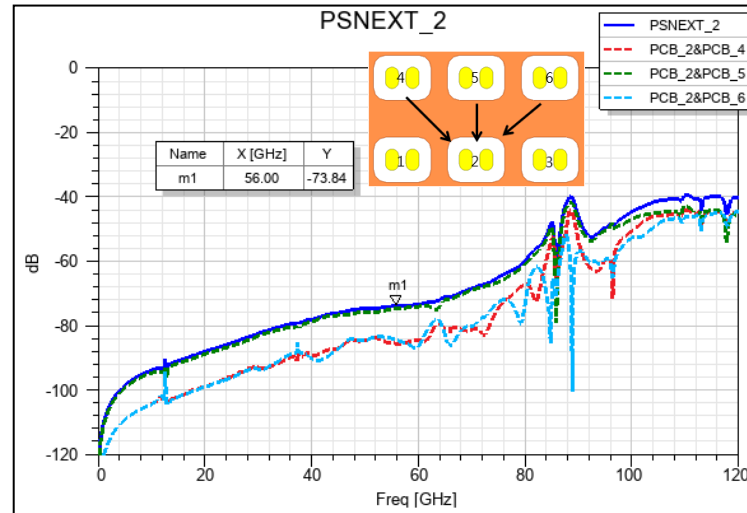
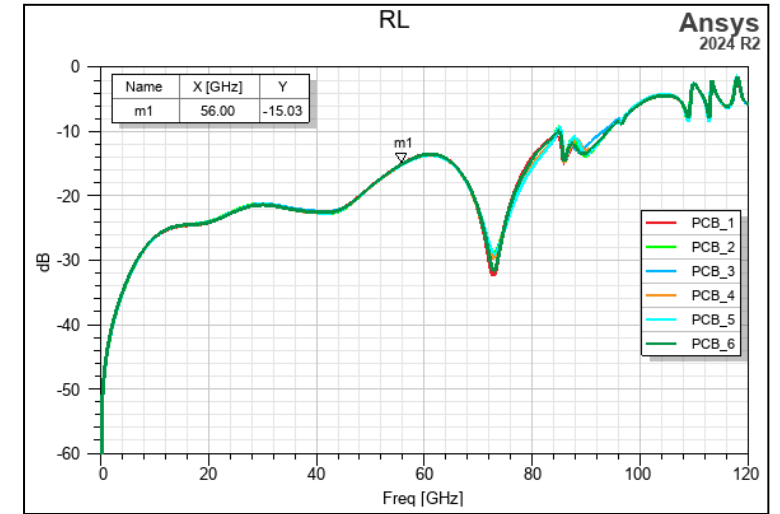
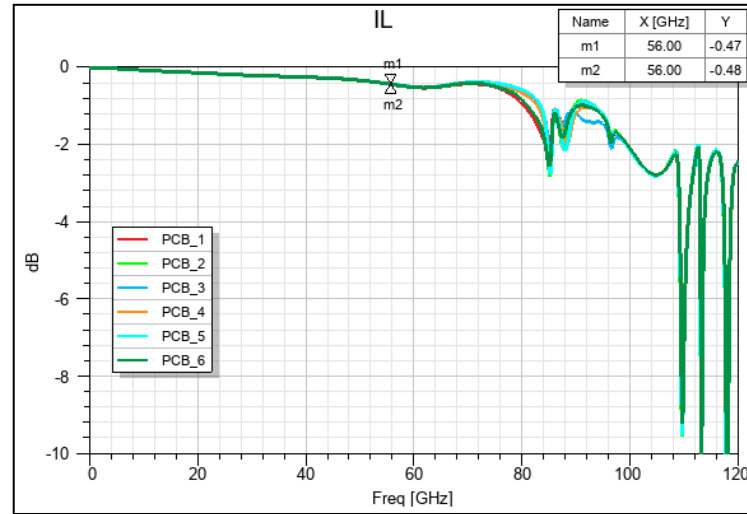
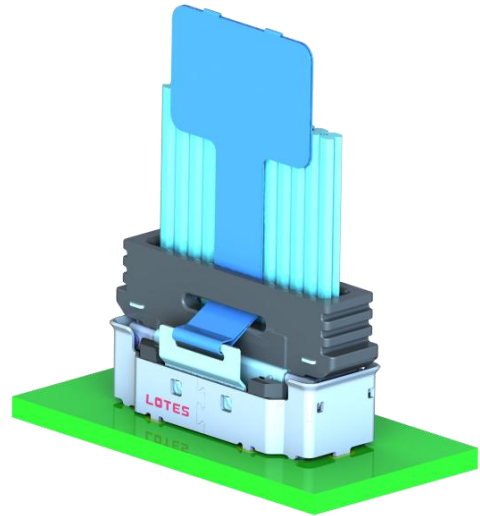



Thank You

SNIA SFF Chair Contact: sff-chair@snia.org

SNIA SFF URL: <https://www.snia.org/sff>