



## SFF-TA-1041

Specification for

# Low Profile PCIe Gen 7 Connector System

Rev 1.0

April 7, 2026

SECRETARIAT: SFF TWG

This specification is made available for public review at <https://www.snia.org/sff/specifications>. Comments may be submitted at <https://www.snia.org/feedback>. Comments received will be considered for inclusion in future revisions of this specification.

This document has been released by SNIA. The SFF TWG believes that the ideas, methodologies, and technologies described in this document are technically accurate and are appropriate for widespread distribution.

The description in this specification does not assure that the specific component is available from suppliers. If such a component is supplied, it should comply with this specification to achieve interoperability between suppliers.

**ABSTRACT:** This specification defines the mechanical and electrical requirements of a pluggable high speed connector and cable system commonly referred to as ULP (Ultra Low Profile) This document provides a common specification for systems manufacturers, system integrators, and suppliers of modules.

**POINTS OF CONTACT:**

SNIA Technical Council Administrator  
Email: [TCA@snia.org](mailto:TCA@snia.org)

Chairman SFF TWG  
Email: [SFF-Chair@snia.org](mailto:SFF-Chair@snia.org)

**EDITOR:**

Dan Gorenc, TE Connectivity

**INTELLECTUAL PROPERTY**

The user's attention is called to the possibility that implementation of this specification may require the use of an invention covered by patent rights. By distribution of this specification, no position is taken with respect to the validity of a claim or claims or of any patent rights in connection therewith.

This specification is covered by the SNIA IP Policy and as a result goes through a request for disclosure when it is published.

Additional information can be found at the following locations:

- Results of IP Disclosures: <https://www.snia.org/sffdisclosures>
- SNIA IP Policy: [https://www.snia.org/about/corporate\\_info/ip\\_policy](https://www.snia.org/about/corporate_info/ip_policy)

**COPYRIGHT**

SNIA hereby grants permission for individuals to use this document for personal use only, and for corporations and other business entities to use this document for internal use only (including internal copying, distribution, and display) provided that:

1. Any text, diagram, chart, table or definition reproduced shall be reproduced in its entirety with no alteration, and,
2. Any document, printed or electronic, in which material from this document (or any portion hereof) is reproduced shall acknowledge the SNIA copyright on that material, and shall credit SNIA for granting permission for its reuse.

Other than as explicitly provided above, there may be no commercial use of this document, or sale of any part, or this entire document, or distribution of this document to third parties. All rights not explicitly granted are expressly reserved to SNIA.

Permission to use this document for purposes other than those enumerated (Exception) above may be requested by e-mailing [copyright\\_request@snia.org](mailto:copyright_request@snia.org). Please include the identity of the requesting individual and/or company and a brief description of the purpose, nature, and scope of the requested use. Permission for the Exception shall not be unreasonably withheld. It can be assumed permission is granted if the Exception request is not acknowledged within ten (10) business days of SNIA's receipt. Any denial of permission for the Exception shall include an explanation of such refusal.

**DISCLAIMER**

The information contained in this publication is subject to change without notice. SNIA makes no warranty of any kind with regard to this specification, including, but not limited to, the implied warranties of merchantability and fitness for a particular purpose. SNIA shall not be liable for errors contained herein or for incidental or consequential damages in connection with the furnishing, performance, or use of this specification.

Suggestions for revisions should be directed to <https://www.snia.org/feedback/>.

**FOREWORD**

The development work on this specification was done by the SNIA SFF TWG, an industry group. Since its formation as the SFF Committee in August 1990, as well as since SFF's transition to SNIA in 2016, the membership has included a mix of companies which are leaders across the industry.

For those who wish to participate in the activities of the SFF TWG, the signup for membership can be found at <https://www.snia.org/join>.

**REVISION HISTORY**

Rev 1.0      *April 7, 2026:*  
              -First publication revision

**CONTENTS**

1.	Scope	6
2.	References and Conventions	6
2.1	Industry Documents	6
2.2	Sources	6
2.3	Conventions	7
3.	Keywords, Acronyms, and Definitions	8
3.1	Keywords	8
3.2	Acronyms and Abbreviations	8
3.3	Definitions	9
4.	General Description	12
4.1	Configuration Overview/Descriptions	12
4.1.1	Right Angle	12
4.2	Contact Numbering	13
5.	Connector Mechanical Specification	14
5.1	Overview	14
5.1.1	Datums	14
5.2	System Offset Mating Limits	15
5.2.1	Vertical Fixed Side/Right Angle Free Side	15
5.3	Mechanical Description: Fixed Side Vertical Connector	16
5.3.1	Fixed Side Vertical Connector X8	17
6.	Free Side Mechanical Specification	20
6.1	Overview	20
6.2	Mechanical Description	21
6.2.1	Right Angle Cable Exit X8	21
7.	Dust Covers	22
8.	Test Requirements and Methodologies (TS-1000, etc.)	23
8.1	Performance Tables	23

**FIGURES**

Figure 3-1 Fixed-side and Free-side Connector Definition	9
Figure 3-2 Plug and Receptacle Definition	10
Figure 3-3 Right Angle Connector and Cable Assembly	11
Figure 3-4 Wipe for a Continuous Contact	11
Figure 4-1 Right Angle	12
Figure 4-2 Contact Numbering	13
Figure 5-1 Datum Definitions	14
Figure 5-2 Offset Mating Limits	15
Figure 5-3 X8 Fixed-Side Overall View	16
Figure 5-4 Fixed-Side Vertical Connector X8	17
Figure 5-5 Fixed Side Vertical Connector Bottom View	18
Figure 5-6 Fixed Side Board Layout	19
Figure 6-1 X8 Free-Side Overall View	21
Figure 6-2 X8 Free Side Right Angle Exit Connector	21
Figure 7-1 Dust Cover Example	22

**TABLES**

Table 5-1 Datum Descriptions	15
Table 8-1 Form Factor Performance Requirements	23
Table 8-2 EIA-364-1000 Test Details	24
Table 8-3 Additional Test Procedures	25

## 1. Scope

This specification defines a cable interconnect system with a two connector design, one which is fixed, and the other which is free. The fixed connector is mounted onto a host board, while the free connector is attached to a cable assembly. This free side connector has a a right angle cable exit direction relative to the mating orientation.

## 2. References and Conventions

### 2.1 Industry Documents

The following documents are relevant to this specification:

- ASME Y14.5                    Dimensioning and Tolerancing
- EIA-364-1000                Environmental Test Methodology for Assessing the Performance of Electrical Connectors and Sockets Used in Controlled Environment Applications
- REF-TA-1011                 Cross Reference to Select SFF Connectors

### 2.2 Sources

The complete list of SFF documents which have been published, are currently being worked on, or that have been expired by the SFF Committee can be found at <https://www.snia.org/sff/specifications>. Suggestions for improvement of this specification are welcome and should be submitted to <https://www.snia.org/feedback>.

Other standards may be obtained from the organizations listed below:

Standard	Organization	Website
ASME	American Society of Mechanical Engineers (ASME)	<a href="https://www.asme.org">https://www.asme.org</a>
Electronic Industries Alliance (EIA)	Electronic Components Industry Association (ECIA)	<a href="https://www.ecianow.org/eia-technical-standards">https://www.ecianow.org/eia-technical-standards</a>
IEEE	Institute of Electrical and Electronics Engineers (IEEE)	<a href="https://ieeexplore.ieee.org/browse/standards/get-program/page/series?id=68">https://ieeexplore.ieee.org/browse/standards/get-program/page/series?id=68</a>
InfiniBand	InfiniBand Trade Association (IBTA)	<a href="https://www.infinibandta.org">https://www.infinibandta.org</a>
JEDEC	Joint Electron Deice Engineering Council (JEDEC)	<a href="https://www.jedec.org">https://www.jedec.org</a>
OIF	Optical Internetworking Forum (OIF)	<a href="https://www.oiforum.com/technical-work/implementation-agreements-ias/">https://www.oiforum.com/technical-work/implementation-agreements-ias/</a>
PCIe	PCI-SIG	<a href="https://www.pcisig.com/specifications">https://www.pcisig.com/specifications</a>
SAS and other ANSI standards	International Committee for Information Technology Standards (INCITS)	<a href="https://www.incits.org">https://www.incits.org</a>

### 2.3 Conventions

The following conventions are used throughout this document:

**DEFINITIONS:** Certain words and terms used in this standard have a specific meaning beyond the normal English meaning. These words and terms are defined either in the definitions or in the text where they first appear.

**ORDER OF PRECEDENCE:** If a conflict arises between text, tables, or figures, the order of precedence to resolve the conflicts is text; then tables; and finally figures. Not all tables or figures are fully described in the text. Tables show data format and values.

**LISTS:** Lists sequenced by lowercase or uppercase letters show no ordering relationship between the listed items.

EXAMPLE 1 - The following list shows no relationship between the named items:

- a. red (i.e., one of the following colors):
  - A. crimson; or
  - B. pink;
- b. blue; or
- c. green.

Lists sequenced by numbers show an ordering relationship between the listed items.

EXAMPLE 2 -The following list shows an ordered relationship between the named items:

- 1. top;
- 2. middle; and
- 3. bottom.

Lists are associated with an introductory paragraph or phrase and are numbered relative to that paragraph or phrase (i.e., all lists begin with an a. or 1. entry).

**DIMENSIONING CONVENTIONS:** The dimensioning conventions are described in ASME-Y14.5, Geometric Dimensioning and Tolerancing. All dimensions are in millimeters, which are the controlling dimensional units (if inches are supplied, they are for guidance only).

**NUMBERING CONVENTIONS:** The ISO convention of numbering is used (i.e., the thousands and higher multiples are separated by a space and a period is used as the decimal point). This is equivalent to the English/American convention of a comma and a period.

<b>American</b>	<b>French</b>	<b>ISO</b>
0.6	0,6	0.6
1,000	1 000	1 000
1,323,462.9	1 323 462,9	1 323 462.9

### 3. Keywords, Acronyms, and Definitions

For the purposes of this document, the following keywords, acronyms, and definitions apply.

#### 3.1 Keywords

**May:** Indicates flexibility of choice with no implied preference.

**May or may not:** Indicates flexibility of choice with no implied preference.

**Obsolete:** Indicates that an item was defined in prior specifications but has been removed from this specification.

**Optional:** Describes features which are not required by the SFF specification. However, if any feature defined by the SFF specification is implemented, it shall be implemented as defined by the specification. Describing a feature as optional in the text is an informational callout to assist the reader.

**Prohibited:** Describes a feature, function, or coded value that is defined in a referenced specification to which this SFF specification makes a reference, where the use of said feature, function, or coded value is not allowed for implementations of this specification.

**Reserved:** Where the term is used for a signal on a connector contact, the function is set aside for future standardization. It is not available for vendor specific use. Where this term is used for bits, bytes, fields, and code values; the bits, bytes, fields, and code values are set aside for future standardization. The default value shall be zero. The originator is required to define a Reserved field or bit as zero, but the receiver should not check Reserved fields or bits for zero.

**Restricted:** Refers to features, bits, bytes, words, and fields that are set aside for other standardization purposes. If the context of the specification applies to the restricted designation, then the restricted bit, byte, word, or field shall be treated as a value whose definition is not in scope of this document, and is not interpreted by this specification.

**Shall:** Indicates a mandatory requirement. Designers are required to implement all such mandatory requirements to ensure interoperability with other products that conform to this specification.

**Should:** Indicates flexibility of choice with a strongly preferred alternative.

**Vendor specific:** Indicates something (e.g., a bit, field, code value) that is not defined by this specification. Specification of the referenced item is determined by the manufacturer and may be used differently in various implementations.

#### 3.2 Acronyms and Abbreviations

**AOC:** Active Optical Cable

**EMLB:** Early Mate Late Break

**IDC:** Insulation Displacement Contact

**IDT:** Insulation Displacement Termination

**PCB:** Printed Circuit Board

**PF:** Press Fit

**PTH:** Plated Through Hole

**RA:** Right Angle

**RAND:** Reasonable and Non-Discriminatory

**SMT:** Surface Mount Technology

### 3.3 Definitions

**Alignment guides:** A term used to describe features that pre-align the two halves of a connector interface before electrical contact is established. Other common terms include guide pins, guideposts, blind mating features, mating features, alignment features, and mating guides.

**Basic (dimension):** The theoretical exact size, profile, orientation, or location of a feature. It is used as the basis from which permissible variations are established by tolerances in notes or in feature control frames (GD&T).

**Connector:** Each half of an interface that, when joined together, establish electrical contact and mechanical retention between two components. In this specification, the term connector does not apply to any specific gender; it is used to describe the receptacle, the plug or the card edge, or the union of receptacle to plug or card edge. Other common terms include connector interface, mating interface, and separable interface.

**Contact mating sequence:** A term used to describe the order of electrical contact established/ terminated during mating/un-mating. Other terms include contact sequencing, contact positioning, mate first/break last, EMLB (early mate late break) staggered contacts, and long pin/short pin.

**Contacts:** A term used to describe connector terminals that make electrical connections across a separable interface.

**Datum:** A point, line, plane, etc. assumed to be exact for the purposes of computation or reference, as established from actual features, and from which the location or geometric relationship of either feature is established.

**Fixed-side connector:** A term used to describe a connector that is terminated to a PCB. An example is shown in Figure 3-1.

**Free-side connector:** A term used to describe connector terminals that make electrical connections across a separable interface (e.g., the cable end). An example is shown in Figure 3-1.

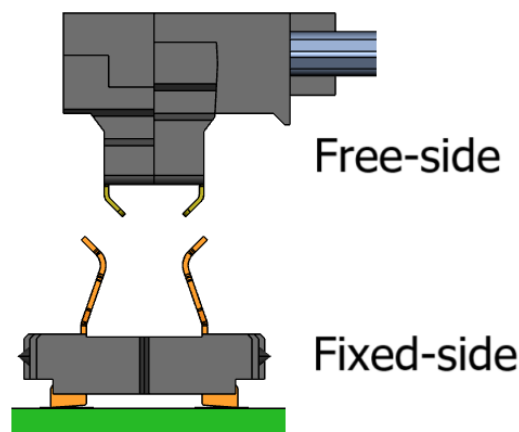
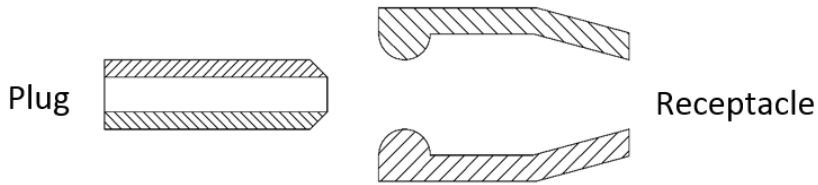

**Figure 3-1 Fixed-side and Free-side Connector Definition**

**Frontshell / Backshell:** A term used to describe the metallic part of a module that provides mechanical and shielding continuity between the plug and receptacle. Other common terms include housing, snout, and metal shroud.

**Module:** In this specification, module may refer to a plug assembly at the end of a copper (electrical) cable (passive or active), an active optical cable assembly, an optical transceiver, or a loopback.

**Plug:** A term used to describe the connector that contains the penetrating contacts of the connector interface as shown in Figure 3-2. Plugs typically contain stationary contacts. Other common terms include male connector, pin connector, and card edge.



**Figure 3-2 Plug and Receptacle Definition**

**Plated through hole termination:** A term used to describe a termination style in which rigid pins extend into or through the PCB. Pins are soldered to keep the connector or cage in place. Other common terms include plated through hole (PTH).

**Press fit:** A term used to describe a termination style in which collapsible pins penetrate the surface of a PCB. Upon insertion, the pins collapse to fit inside the PCB’s plated through holes. The connector or cage is held in place by the interference fit between the collapsed pins and the PCB.

**Receptacle:** A term used to describe the connector that contains the contacts that accept the plug contacts as shown in Figure 3-2. Receptacles typically contain spring contacts. Other common terms include female connector and socket connector.

**Reference (dimension):** A dimension provided for information or convenience. It has no tolerance and is not to be used for inspection or conformance. It can be calculated from other tolerance dimensions or can be found elsewhere on the drawing with a tolerance. If removed, it would have no impact on the defined object or the ability to reproduce it.

**Right Angle:** A term used to describe either a connector design where the mating direction is parallel to the plane of the printed circuit board upon which the connector is mounted or a cable assembly design where the mating direction is perpendicular to the bulk cable.

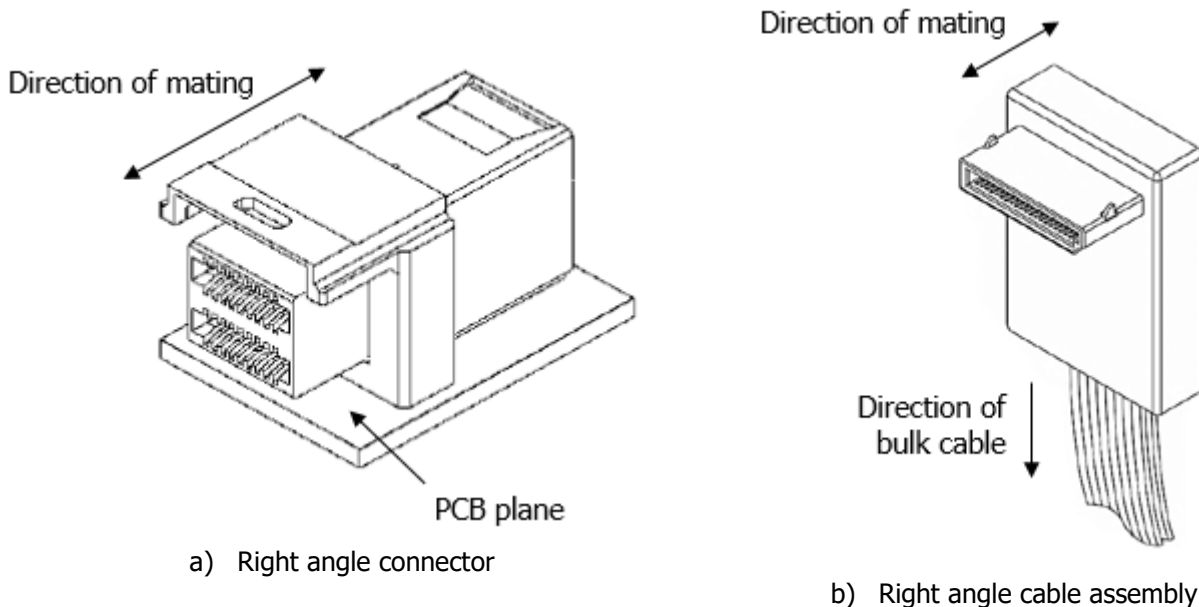

### Figure 3-3 Right Angle Connector and Cable Assembly

**Straddle mount:** A term used to describe a termination style that uses surface mount termination points on both sides of a PCB.

**Straight:** A term used to describe a connector design where the mating direction is parallel to the bulk cable.

**Surface mount:** A term used to describe a termination style in which solder tails sit on pads on the surface of a PCB and are then soldered to keep the connector or cage in place. Other common terms include surface mount technology (SMT).

**Termination:** A term used to describe a connector's non-separable attachment point such as [a connector contact to a bulk cable/ a cage to a PCB or flex circuit/ bulk cable to a PCB or flex circuit/ solder tail to PCB]. Common PCB terminations include surface mount technology (SMT), plated through hole (PTH), and press fit (PF). Common cable terminations include insulation displacement contact (IDC), insulation displacement termination (IDT), wire slots, solder, welds, crimps, and brazes.

**Vertical:** A term used to describe a connector design where the mating direction is perpendicular to the printed circuit board upon which the connector is mounted.

**Wipe:** The distance a contact travels on the surface of its mating contact during the mating cycle as shown in Figure 3-4.

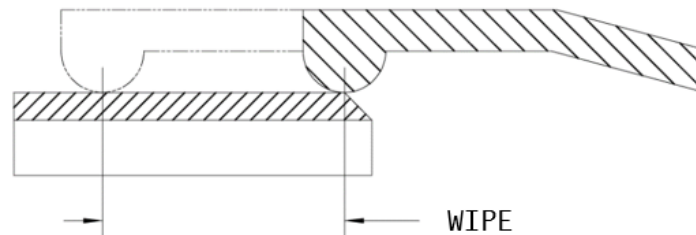

**Figure 3-4 Wipe for a Continuous Contact**

## 4. General Description

### 4.1 Configuration Overview/Descriptions

The ULP connector system is composed of two components: a fixed (board mounted) connector and a mating free (cable mounted) right angle exit connector. The free connector mates to the fixed connector in a direction perpendicular to the board surface.

#### 4.1.1 Right Angle

The right angle configuration consists of the common vertical fixed side connector and a mating free-side connector where the cable exits the free side connector parallel to the board surface (at right angle to the mating direction of the connectors).

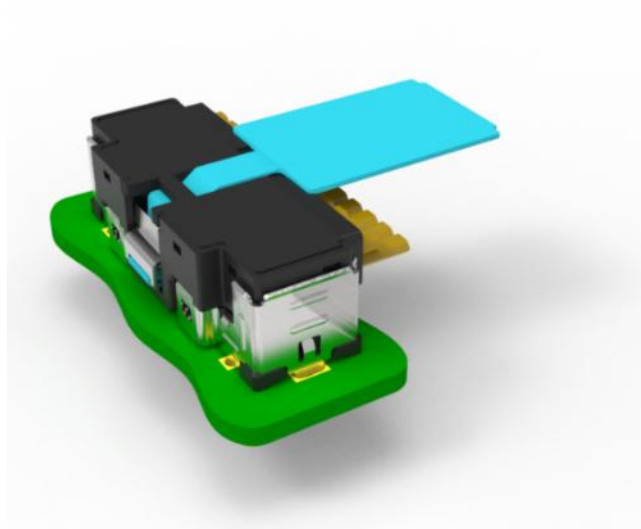

Figure 4-1 Right Angle

### 4.2 Contact Numbering

The pins or electrical contacts in this connector are numbered as shown in Figure 4-2.

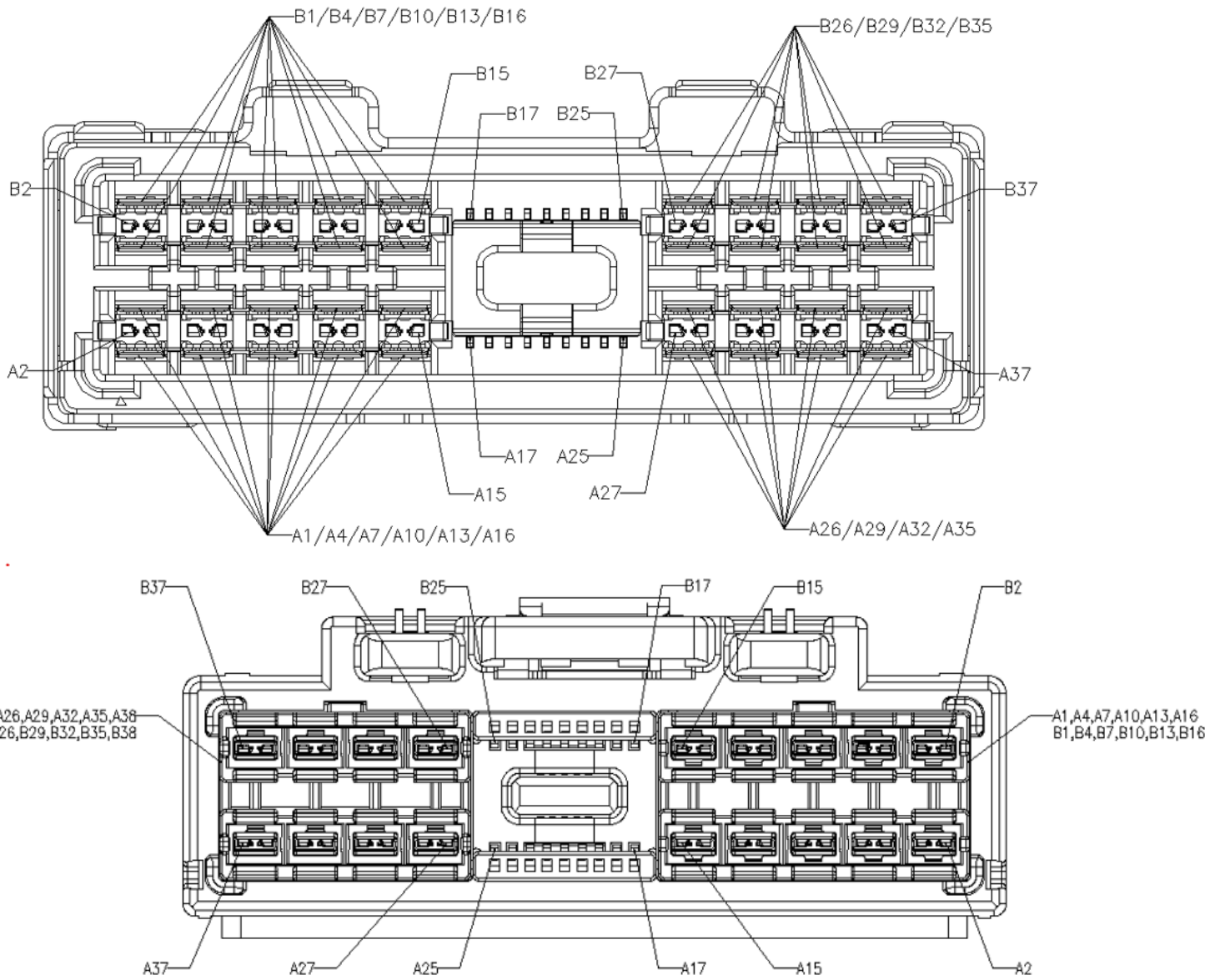

Figure 4-2 Contact Numbering

## 5. Connector Mechanical Specification

### 5.1 Overview

The vertical board mounted connector (Fixed Side Connector) is a 76 position X8 receptacle that will accommodate the mating cable mounted (Free-Side Connector) Plug.

#### 5.1.1 Datums

The datums defined in Figure 5-1 and Table 5-1 are used throughout the rest of the document to describe the dimensional requirements of this connector.

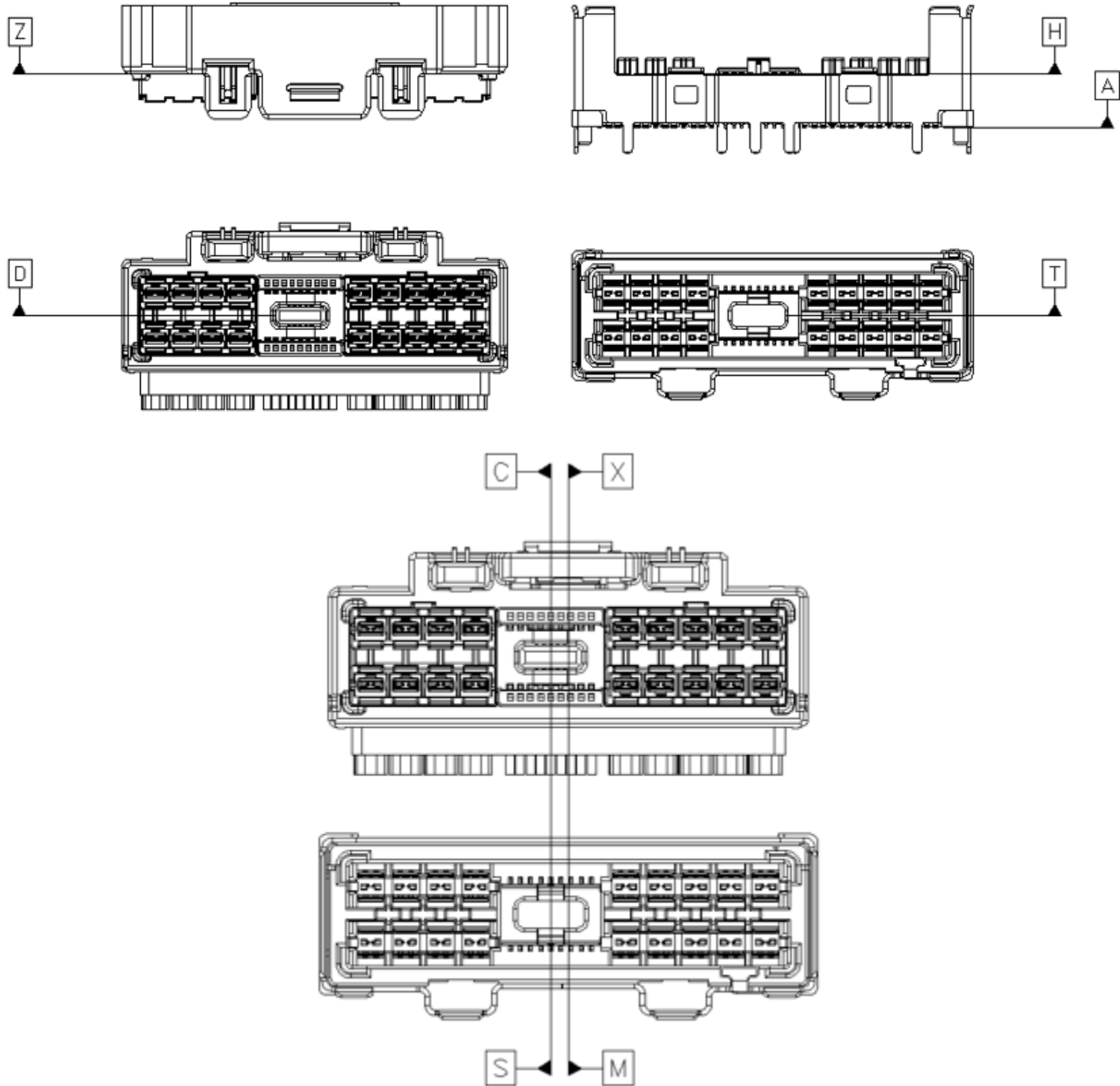

Figure 5-1 Datum Definitions

**Table 5-1 Datum Descriptions**

Datum	Description
A	Fixed Side Housing (Bottom)
C	Free-Side centerline X-direction mate Side
D	Free-Side centerline Y-direction mate Side
H	Fixed-Side Housing Hard Stop
M	Fixed-Side centerline X-direction
S	Fixed-Side centerline X-direction mate Side
T	Fixed-Side centerline Y-direction mate Side
X	Free-Side centerline X-direction
Z	Free-Side Housing Hard Stop

## 5.2 System Offset Mating Limits

### 5.2.1 Vertical Fixed Side/Right Angle Free Side

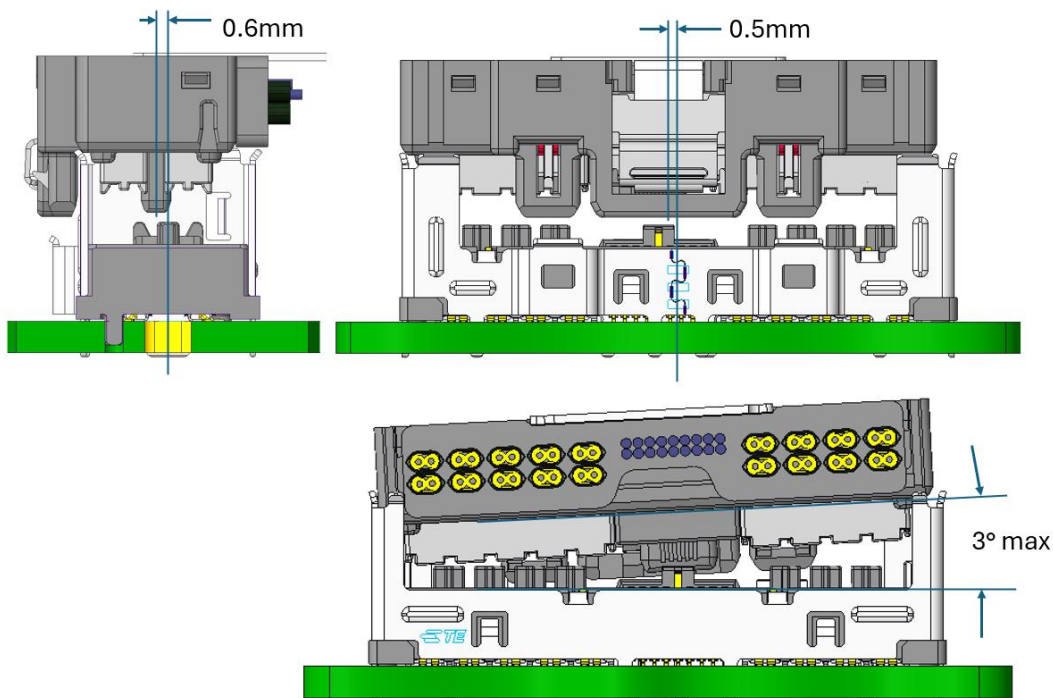

**Figure 5-2 Offset Mating Limits**

### 5.3 Mechanical Description: Fixed Side Vertical Connector

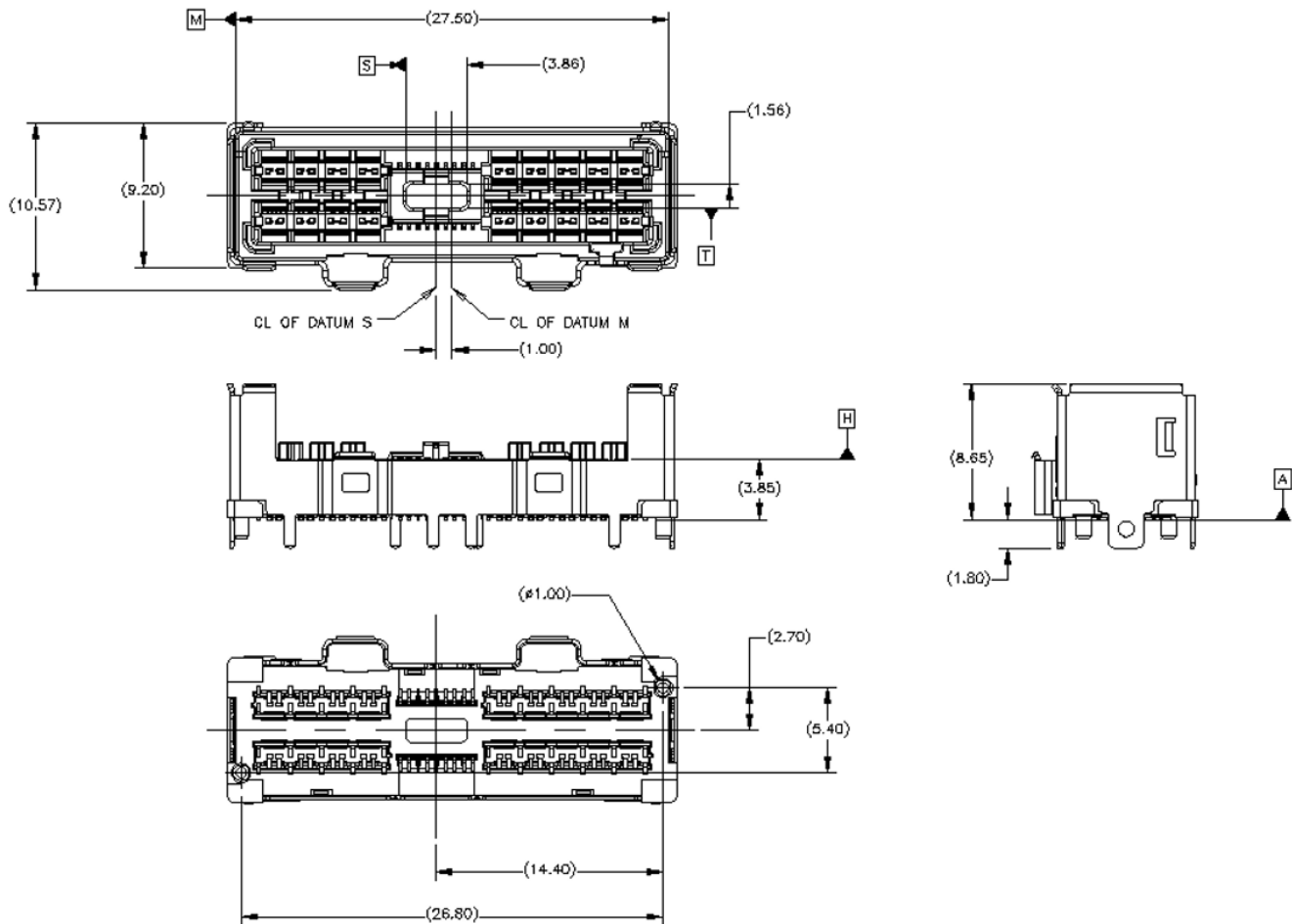
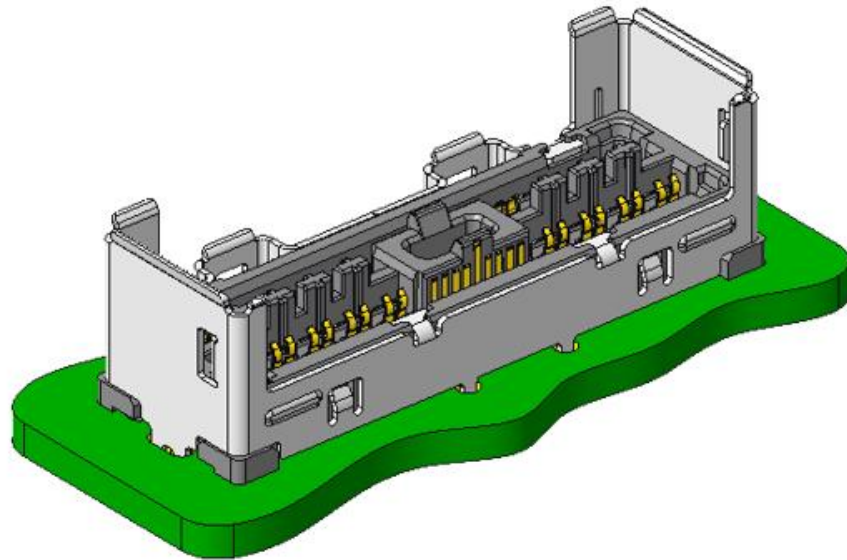

Figure 5-3 X8 Fixed-Side Overall View

### 5.3.1 Fixed Side Vertical Connector X8

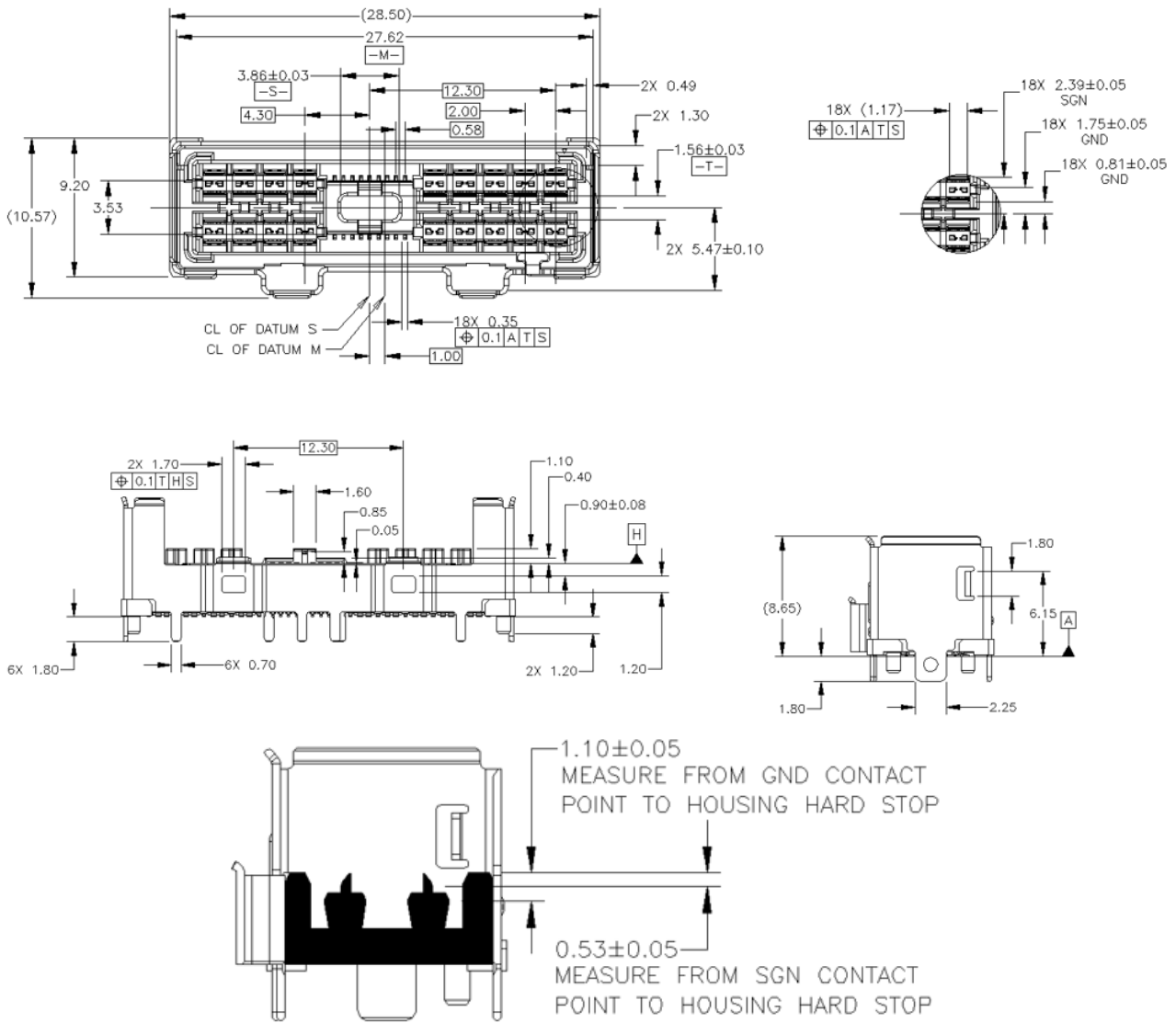

Figure 5-4 Fixed-Side Vertical Connector X8

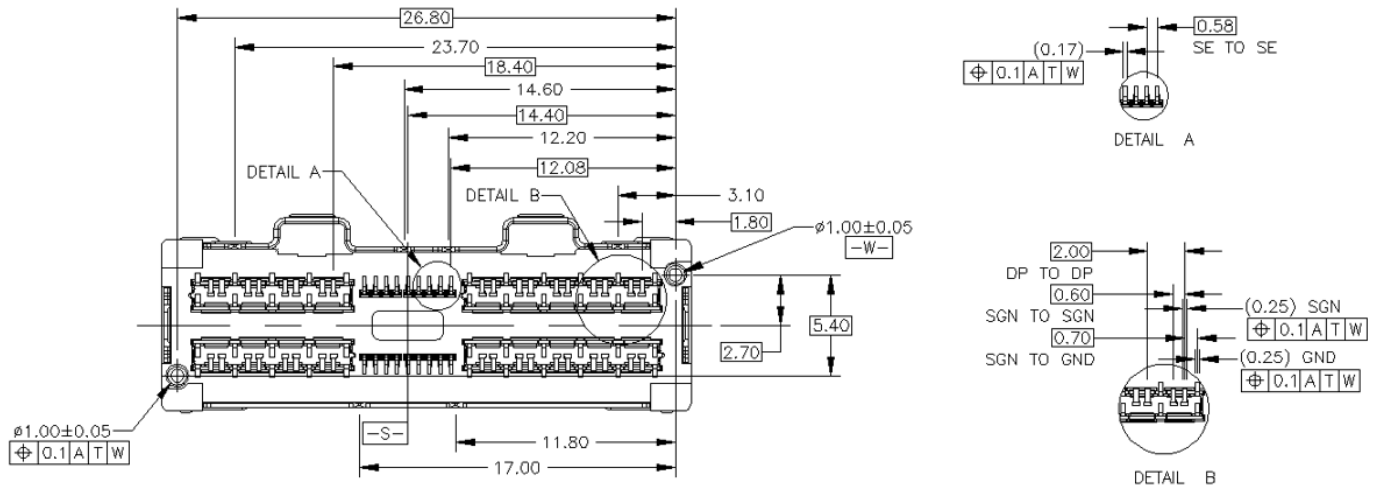

Figure 5-5 Fixed Side Vertical Connector Bottom View

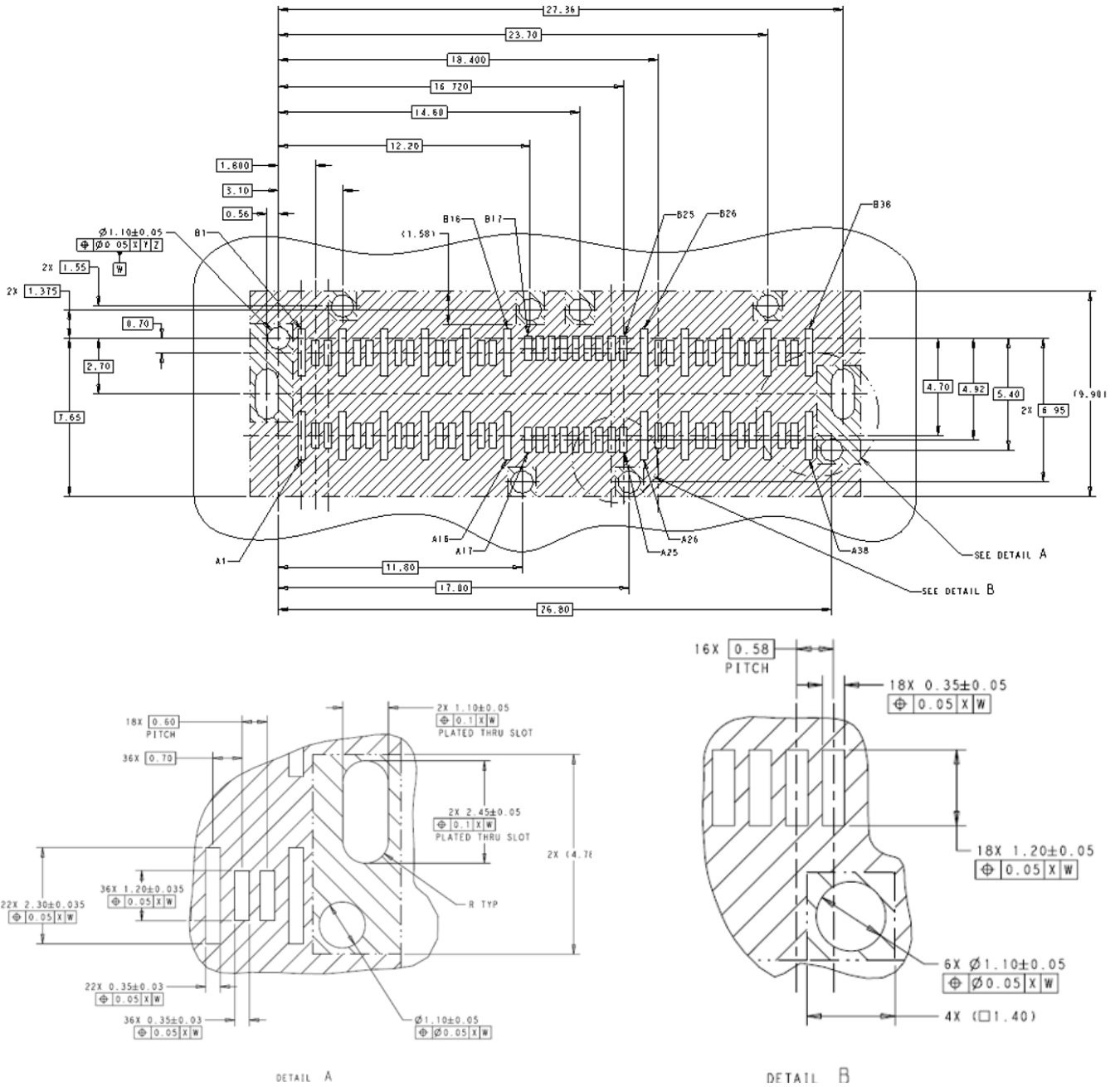

Figure 5-6 Fixed Side Board Layout

## 6. Free Side Mechanical Specification

### 6.1 Overview

The cable mounted plug (Free-Side Connector) is a 76 position X8 plug that will mate with the fixed side connector as described in the previous sections.

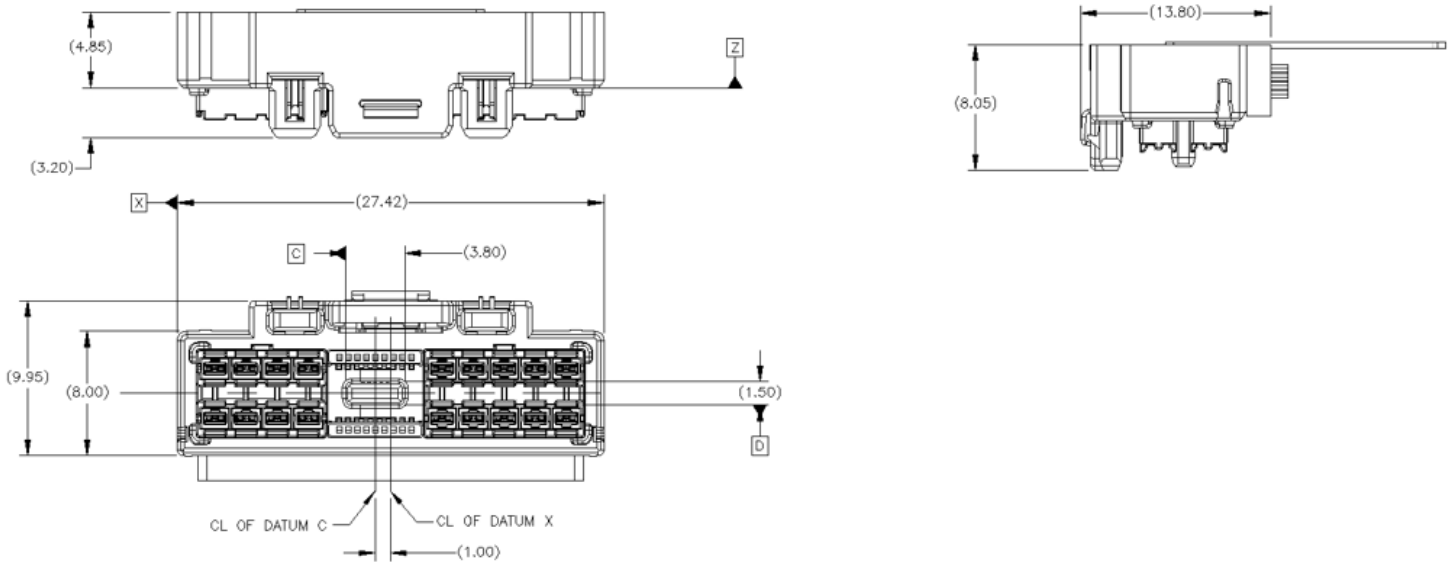
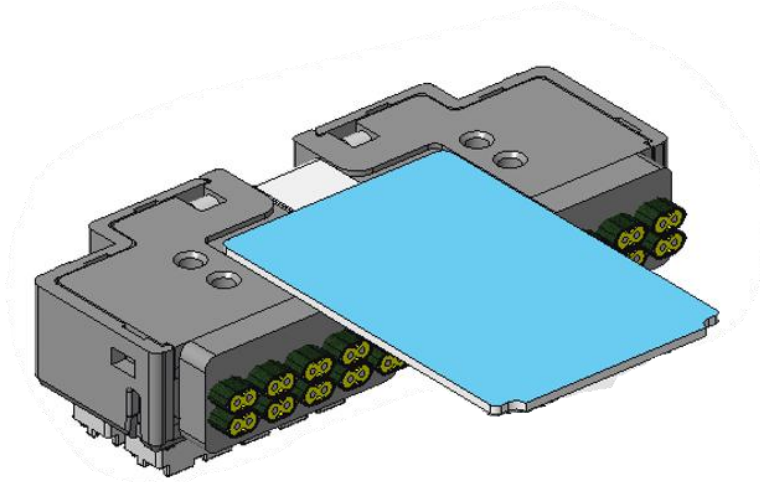

Figure 6-1 X8 Free-Side Overall View

6.2 Mechanical Description

6.2.1 Right Angle Cable Exit X8

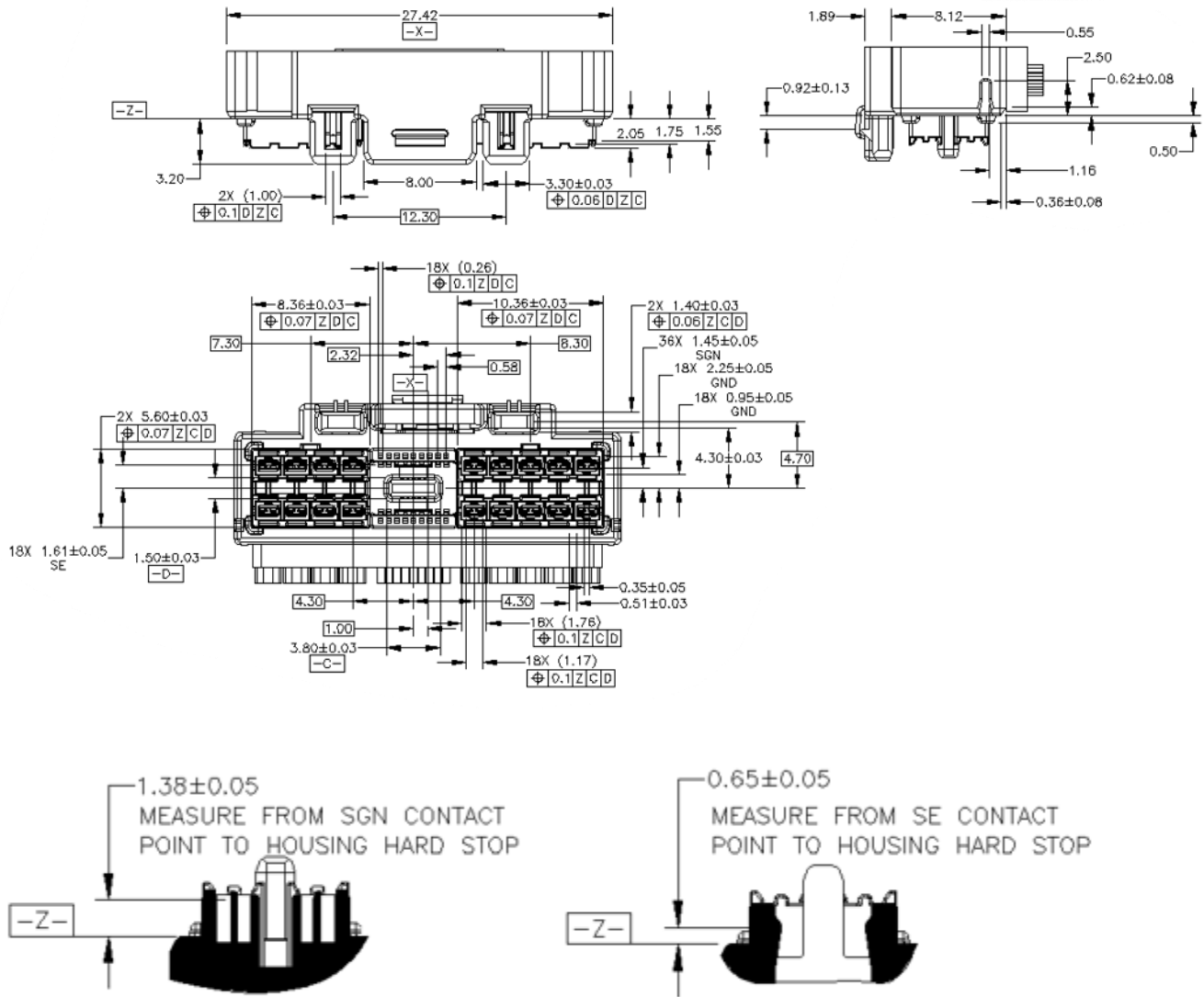
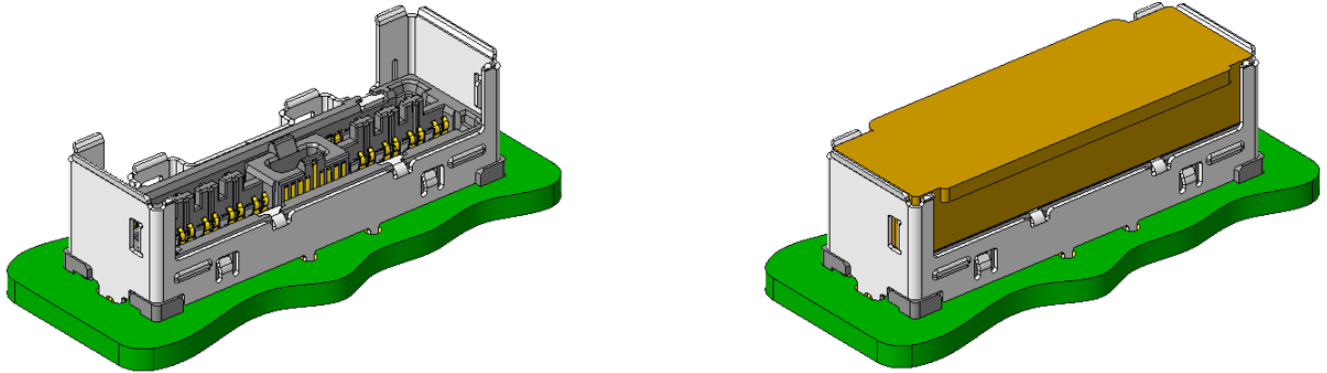

Figure 6-2 X8 Free Side Right Angle Exit Connector

## 7. Dust Covers

While recommended, dust covers are optional, especially for the Fixed Side connectors. These covers could be used to aid pick and place and are at the discretion of the manufacturer. An example of a dust cover is shown in Fig. 6-2.



**Figure 7-1 Dust Cover Example**

## 8. Test Requirements and Methodologies (TS-1000, etc.)

### 8.1 Performance Tables

EIA-364-1000 (TS-1000) shall be used to define the test sequences and procedures for evaluating the connector system described in this document. Where multiple test options are available, the manufacturer shall select the appropriate option where not previously specified. The selected procedure should be noted when reporting data. If there are conflicting requirements or test procedures between EIA-364 procedures and those contained within this document, this document shall be considered the prevailing authority.

Unless otherwise specified, procedures for sample size, data, and collection to be followed as specified in EIA-364-1000. See EIA-364-1000 Annex B for objectives of tests and test groups.

Table 8-1 summarizes the performance criteria that are to be satisfied by the connector described in this document. Most performance criteria are validated by EIA-364-1000 testing, but this test suite leaves some test details to be determined. To ensure that testing is repeatable, these details are identified in Table 8-2. Finally, testing procedures used to validate any performance criteria not included in EIA-364-1000 are provided in Table 8-3.

**Table 8-1 Form Factor Performance Requirements**

Performance Parameters	Description/ Details	Requirement
<b>Mechanical/ Physical Requirements</b>		
<b>Plating Type</b>	Plating type on connector contacts	Precious
<b>Surface Treatment</b>	Surface treatment on connector contacts	Non-lubricated
<b>Wipe length</b>	Designed distance a contact traverses over a mating contact surface during mating and resting at a final position	Greater than 0.2 mm
<b>Rated Durability Cycles</b>	The expected number of durability cycles a component is expected to encounter over the course of its life	Connector/ cage: 100 cycles
<b>Latched Mating Force*</b>	Amount of force needed to mate a module with a connector when latches are deactivated	45 N max
<b>Unlatched Unmating Force*</b>	Amount of force needed to separate a module from a connector when latches are deactivated	45 N max
<b>Latch Retention*</b>	Amount of force the latching mechanism can withstand	50 N min
<b>Environmental Requirements</b>		
<b>Field Life</b>	The expected service life for a component	10 years
<b>Field Temperature</b>	The expected service temperature for a component	65°C
<b>Storage Temperature*</b>	The expected storage temperature for a component when not in use	-40 °C to +85 °C
<b>Storage Humidity*</b>	The maximum expected storage humidity for a component when not in use	80% Relative Humidity

Performance Parameters	Description/ Details	Requirement
<b>Electrical Requirements</b>		
<b>Current*</b>	Maximum current to which a contact is exposed in use	0.25 A per contact max
<b>Operating Rating Voltage</b>	Maximum voltage to which a contact is exposed in use	29 V DC per contact max
<b>NOTE: Performance criteria denoted with stars (*) are not validated by EIA-364-1000 testing. Refer to Table 8-3 for test procedures and pass/fail criteria.</b>		

Table 8-2 describes the details necessary to perform the tests described in the EIA-364-1000 test sequences. Testing shall be done in accordance with EIA-364-1000 and the test procedures it identifies in such a way that the parameters/ requirements defined in Table 8-1 are met. Any information in this table supersedes EIA-364-1000.

**Table 8-2 EIA-364-1000 Test Details**

Test	Test Descriptions and Details	Pass/ Fail Criteria
<b>Mechanical/ Physical Tests</b>		
<b>Durability (preconditioning)</b>	EIA-364-09 To be tested with connector, cage, and module (Latches should not be locked)	No evidence of physical damage
<b>Durability (see Note 1)</b>	EIA-364-09 To be tested with connector, cage, and module (Latches should not be locked out per EIA-364-1000)	No visual damage to mating interface or latching mechanism
<b>Environmental Tests</b>		
<b>Mixed Flowing Gas (see Note 2)</b>	EIA-364-65 Class IIA See Table 4.1 in EIA-364-1000 for exposure times Test option Per EIA-364-1000: 4	No intermediate test criteria
<b>Electrical Tests</b>		
<b>Low Level Contact Resistance (see Note 3)</b>	EIA-364-23 20 mV DC max, 100 mA max To include wire termination or connector-to-board termination	15 mΩ max change from baseline
<b>Dielectric Withstanding Voltage</b>	EIA-364-20 Method B 300 VDC minimum for 1 minute	No defect or breakdown between adjacent contacts
<b>NOTES:</b>		
<ol style="list-style-type: none"> <li>1. If the durability requirement on the connector is greater than that of the module, modules may be replaced after their specified durability rating.</li> <li>2. Test option, temperature, duration must be reported.</li> <li>3. The first low level contact resistance reading in each test sequence is used to determine a baseline measurement. Subsequent measurements in each sequence are measured against this baseline.</li> </ol>		

Table 8-3 describes the testing procedures necessary to validate performance criteria not validated by EIA-364-1000 testing. The tests are to be performed in such a way that the parameters/ requirements defined in Table 8-1 are met.

**Table 8-3 Additional Test Procedures**

Test	Test Descriptions and Details	Pass/ Fail Criteria
<b>Mechanical/ Physical Tests</b>		
<b>Mating Force</b>	EIA-364-13 To be tested with cage, connector, and module without heat sinks Latching mechanism deactivated (locked out)	Refer to Table 8-1 -AND- No physical damage to any components
<b>Unmating Force</b>	EIA-364-13 To be tested with cage, connector, and module without heat sinks Latching mechanism deactivated (locked out)	
<b>Latch Retention</b>	EIA-364-13 To be tested with cage, connector, and module without heat sinks Latching mechanism engaged (not locked out)	
<b>Environmental Tests</b>		
<b>Storage Temperature</b>	EIA-364-32 Method A, Test Condition 1, Duration 4 Use min and max Field Temperatures listed in Table 8-1 for temperature range	Refer to Table 8-1
<b>Storage Humidity</b>	EIA-364-31	Refer to Table 8-1
<b>Electrical Tests</b>		
<b>Current</b>	EIA-364-70 Method 3, 30-degree temperature rise Contacts energized: All	Refer to Table 8-1 for current magnitude