

1
2
3
4

5
6
7
8
9
10
11
12
13
14
15
16
17
18
19
20
21
22
23
24
25
26
27
28
29
30
31
32
33
34



SFF-TA-1044

Specification for

Hybrid Orthogonal EDSFF Connector System

Rev 0.0.2

February 6, 2026

SECRETARIAT: SFF TWG

This specification is made available for public review at <https://www.snia.org/sff/specifications>. Comments may be submitted at <https://www.snia.org/feedback>. Comments received will be considered for inclusion in future revisions of this specification.

This document has been released by SNIA. The SFF TWG believes that the ideas, methodologies, and technologies described in this document are technically accurate and are appropriate for widespread distribution.

The description in this specification does not assure that the specific component is available from suppliers. If such a component is supplied, it should comply with this specification to achieve interoperability between suppliers.

ABSTRACT: This specification defines the hybrid orthogonal interconnect system: a PCB mount connector with a standard EDSFF interface and a cable plug interface, and a cable assembly that pass the signals from the connector to a host board. The connector can accept 1C, 2C and 4C EDSFF devices.

POINTS OF CONTACT:

SNIA Technical Council Administrator
Email: TCA@snia.org

Chairman SFF TWG
Email: SFF-Chair@snia.org

EDITORS:

Zhineng Fan, Amphenol Corporation

INTELLECTUAL PROPERTY

The user's attention is called to the possibility that implementation of this specification may require the use of an invention covered by patent rights. By distribution of this specification, no position is taken with respect to the validity of a claim or claims or of any patent rights in connection therewith.

This specification is covered by the SNIA IP Policy and as a result goes through a request for disclosure when it is published.

The SNIA IP Review Process is still in progress and is completing on xx xx, xxxx. If IP disclosures that affect this specification are made during this process, this specification may be withdrawn.

Additional information can be found at the following locations:

- Results of IP Disclosures: <https://www.snia.org/sffdisclosures>
- SNIA IP Policy: https://www.snia.org/about/corporate_info/ip_policy

COPYRIGHT

SNIA hereby grants permission for individuals to use this document for personal use only, and for corporations and other business entities to use this document for internal use only (including internal copying, distribution, and display) provided that:

1. Any text, diagram, chart, table or definition reproduced shall be reproduced in its entirety with no alteration, and,
2. Any document, printed or electronic, in which material from this document (or any portion hereof) is reproduced shall acknowledge the SNIA copyright on that material, and shall credit SNIA for granting permission for its reuse.

Other than as explicitly provided above, there may be no commercial use of this document, or sale of any part, or this entire document, or distribution of this document to third parties. All rights not explicitly granted are expressly reserved to SNIA.

Permission to use this document for purposes other than those enumerated (Exception) above may be requested by e-mailing copyright_request@snia.org. Please include the identity of the requesting individual and/or company and a brief description of the purpose, nature, and scope of the requested use. Permission for the Exception shall not be unreasonably withheld. It can be assumed permission is granted if the Exception request is not acknowledged within ten (10) business days of SNIA's receipt. Any denial of permission for the Exception shall include an explanation of such refusal.

DISCLAIMER

The information contained in this publication is subject to change without notice. SNIA makes no warranty of any kind with regard to this specification, including, but not limited to, the implied warranties of merchantability and fitness for a particular purpose. SNIA shall not be liable for errors contained herein or for incidental or consequential damages in connection with the furnishing, performance, or use of this specification.

Suggestions for revisions should be directed to <https://www.snia.org/feedback/>.

1 **FOREWORD**

2 The development work on this specification was done by the SNIA SFF TWG, an industry group. Since its formation
3 as the SFF Committee in August 1990, as well as since SFF's transition to SNIA in 2016, the membership has
4 included a mix of companies which are leaders across the industry.
5

6 For those who wish to participate in the activities of the SFF TWG, the signup for membership can be found at
7 <https://www.snia.org/join>.
8
9

10 **REVISION HISTORY**

- 11 **Rev 0.0.1** *November 23, 2025:*
12 -Initial draft
13
14 **Rev 0.0.2** February 6, 2026
15 -Update drawings in Section 5 and Section 6
16 -Add connector type description
17 -Editorial change in Section 4.1
18
19
20

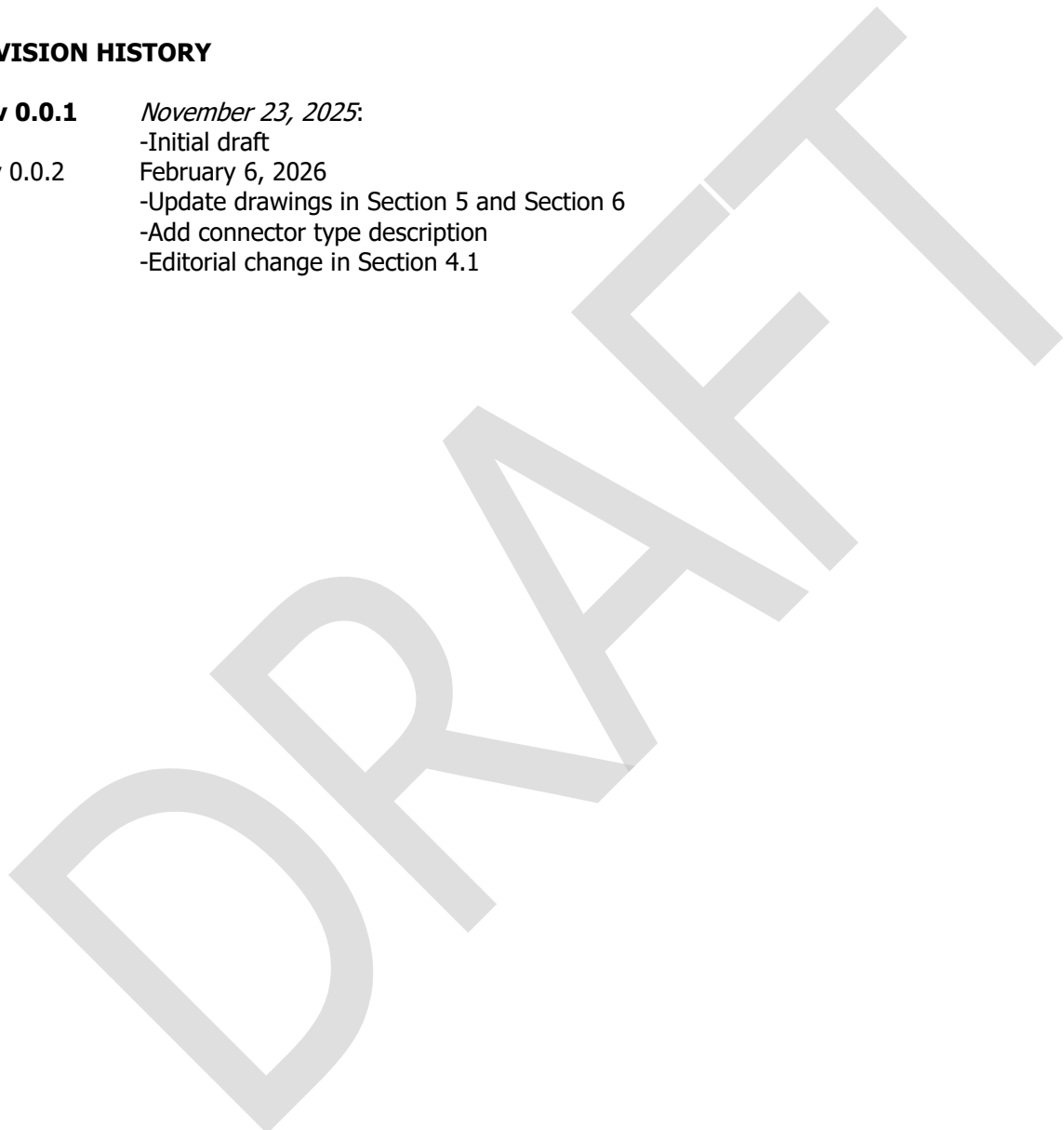

1	CONTENTS	
2	1. Scope	7
3	2. References and Conventions	7
4	2.1 Industry Documents	7
5	2.2 Sources	7
6	2.3 Conventions	8
7	3. Keywords, Acronyms, and Definitions	9
8	3.1 Keywords	9
9	3.2 Acronyms and Abbreviations	9
10	3.3 Definitions	9
11	4. General Description	13
12	4.1 Configuration Overview/Descriptions	13
13	4.1.1 Connector Configuration 1 – 1C-RS20	14
14	4.1.2 Connector Configuration 2 – 1C-RS24	14
15	4.1.3 Connector Configuration 3 – 2C-RS20	14
16	4.1.4 Connector Configuration 4 – 2C-RS24	15
17	4.1.5 Connector Configuration 5 – 4C-RS20	15
18	4.1.6 Connector Configuration 6 – 4C-RS24	15
19	4.2 Contact Numbering	16
20	5. Connector Mechanical Specification	21
21	5.1 Overview	21
22	5.2 Mechanical Description: Hybrid Orthogonal 1C Connector	21
23	5.2.1 Hybrid Orthogonal 1C-RS20 Connector	21
24	5.2.2 Hybrid Orthogonal 1C-RS24 Connector	23
25	5.3 Mechanical Description: Hybrid Orthogonal 2C Connector	25
26	5.3.1 Hybrid Orthogonal 2C-RS20 Connector	25
27	5.3.2 Hybrid Orthogonal 2C-RS24 Connector	28
28	5.4 Mechanical Description: Hybrid Orthogonal 4C Connector	29
29	5.4.1 Hybrid Orthogonal 4C-RS20 Connector	29
30	5.4.2 Hybrid Orthogonal 4C-RS24 Connector	31
31	6. Module Mechanical Specification	32
32	6.1 Overview	32
33	6.2 Mechanical Description: 1C Plug Modules	32
34	6.2.1 1C-RS20 Plug Module	32
35	6.2.2 1C-RS24 Plug Module	33
36	6.3 Mechanical Description: 2C Plug Modules	34
37	6.3.1 2C-RS20 Plug Module	34
38	6.3.2 2C-RS24 Plug Module	35
39	6.4 Mechanical Description: 4C Plug Modules	36
40	6.4.1 4C-RS20 Plug Module	36
41	6.4.2 4C-RS24 Plug Module	38
42	7. Test Requirements and Methodologies (TS-1000, etc.)	39
43	7.1 Performance Tables	39
44	Appendix A. System Mechanical Specification (Informative)	42
45	A.1. Overview	42
46	A.2. PCB Layout	42
47	A.2.1 Standalone Connector Footprint	42

1 **A.2.2 Ganged Connector Footprint** 43

2 Appendix B. Labeling Connector Type (Informative) 44

3

4

5

6



1	FIGURES	
2	Figure 3-1 Fixed-side and Free-side Connector Definition	10
3	Figure 3-2 Plug and Receptacle Definition	11
4	Figure 3-3 Right Angle Connector and Cable Assembly	11
5	Figure 3-4 Wipe for a Continuous Contact	12
6	Figure 4-1 Hybrid Orthogonal EDSFF Connector System Overview	13
7	Figure 4-2 Connector Configuration Overview	13
8	Figure 4-3 1C Hybrid Orthogonal Connector Receptacle and Plug with RS20	14
9	Figure 4-4 1C Hybrid Orthogonal Connector Receptacle and Plug with RS24	14
10	Figure 4-5 2C Hybrid Orthogonal Connector Receptacle and Plug with RS20	14
11	Figure 4-6 2C Hybrid Orthogonal Connector Receptacle and Plug with RS24	15
12	Figure 4-7 4C Hybrid Orthogonal Connector Receptacle and Plug with RS20	15
13	Figure 4-8 4C Hybrid Orthogonal Connector Receptacle and Plug with RS24	15
14	Figure 4-9 Contact Numbering of Receptacle Connectors with RS20	16
15	Figure 4-10 Contact Numbering of Receptacle Connectors with RS24	17
16	Figure 4-11 Contact Numbering of Plugs with RS20	18
17	Figure 4-12 Contact Numbering of Plugs with RS24	19
18	Figure 4-13 Pin Numbering of PCB Footprint with RS20	20
19	Figure 4-14 Pin Numbering of PCB Footprint with RS24	20
20	Figure 5-1 Standalone 1C-RS20 Connector	22
21	Figure 5-2 Ganged 1C-RS20 Connector	23
22	Figure 5-3 1C-RS24 Connector	24
23	Figure 5-4 Ganged 1C-RS24 Connector	25
24	Figure 5-5 2C-RS20 Connector	26
25	Figure 5-6 Ganged 2C-RS20 Connector	27
26	Figure 5-7 2C-RS24 Connector	28
27	Figure 5-8 2C-RS24 Connector	29
28	Figure 5-9 Ganged 4C-RS20 Connector	30
29	Figure 5-10 Ganged 4C-RS24 Connector	31
30	Figure 6-1 1C-RS20 Plug Module	32
31	Figure 6-2 1C-RS24 Plug Module	33
32	Figure 6-3 2C-RS20 Plug Module	35
33	Figure 6-4 2C-RS24 Plug Module	36
34	Figure 6-5 4C-RS20 Plug Module	37
35	Figure 6-6 4C-RS24 Plug Module	38
36	Figure A-1 Recommended Standalone Connector Footprint with RS20	42
37	Figure A-2 Recommended Standalone Connector Footprint with RS24	43
38	Figure A-3 Recommended Ganged Connector Footprint with RS20	43
39	Figure A-4 Recommended Ganged Connector Footprint with RS24	44
40	Figure B-1 1C Connector Label Location	45
41	Figure B-2 2C Connector Label Location	45
42	Figure B-3 4C Connector Label Location	46
43		
44		
45	TABLES	
46	Table 7-1 Form Factor Performance Requirements	39
47	Table 7-2 EIA-364-1000 Test Details	40
48	Table 7-3 Additional Test Procedures	41
49		
50		

1. Scope

This specification defines the general description of this form factor, the connector and mating plug mechanical specification, some performance requirements, and the electrical interface. Additional informative information such as PCB layout is included in an appendix.

2. References and Conventions

2.1 Industry Documents

The following documents are relevant to this specification:

- ASME Y14.5 Dimensioning and Tolerancing
- EIA-364-1000 Environmental Test Methodology for Assessing the Performance of Electrical Connectors and Sockets Used in Controlled Environment Applications
- SNIA-SFF-TA-1002 Protocol Agnostic Multi-Lane High Speed Connector
- SNIA-SFF-TA-1005 Universal Backplane Management (UBM)
- SNIA-SFF-TA-1008 Enterprise and Datacenter Standard Form Factor (E3)
- SNIA-SFF-TA-1009 Enterprise and Datacenter Standard Form Factor Pin and Signal Specification
- SNIA-SFF-TA-1045 Pin and Signal Definition for the Hybrid Orthogonal EDSFF Connector Specification

2.2 Sources

The complete list of SFF documents which have been published, are currently being worked on, or that have been expired by the SFF Committee can be found at <https://www.snia.org/sff/specifications>. Suggestions for improvement of this specification are welcome and should be submitted to <https://www.snia.org/feedback>.

Other standards may be obtained from the organizations listed below:

Standard	Organization	Website
ASME	American Society of Mechanical Engineers (ASME)	https://www.asme.org
Electronic Industries Alliance (EIA)	Electronic Components Industry Association (ECIA)	https://www.ecianow.org/eia-technical-standards

2.3 Conventions

The following conventions are used throughout this document:

DEFINITIONS: Certain words and terms used in this standard have a specific meaning beyond the normal English meaning. These words and terms are defined either in the definitions or in the text where they first appear.

ORDER OF PRECEDENCE: If a conflict arises between text, tables, or figures, the order of precedence to resolve the conflicts is text; then tables; and finally figures. Not all tables or figures are fully described in the text. Tables show data format and values.

LISTS: Lists sequenced by lowercase or uppercase letters show no ordering relationship between the listed items.

EXAMPLE 1 - The following list shows no relationship between the named items:

- a. red (i.e., one of the following colors):
 - A. crimson; or
 - B. pink;
- b. blue; or
- c. green.

Lists sequenced by numbers show an ordering relationship between the listed items.

EXAMPLE 2 -The following list shows an ordered relationship between the named items:

- 1. top;
- 2. middle; and
- 3. bottom.

Lists are associated with an introductory paragraph or phrase and are numbered relative to that paragraph or phrase (i.e., all lists begin with an a. or 1. entry).

DIMENSIONING CONVENTIONS: The dimensioning conventions are described in ASME-Y14.5, Geometric Dimensioning and Tolerancing. All dimensions are in millimeters, which are the controlling dimensional units (if inches are supplied, they are for guidance only).

NUMBERING CONVENTIONS: The ISO convention of numbering is used (i.e., the thousands and higher multiples are separated by a space and a period is used as the decimal point). This is equivalent to the English/American convention of a comma and a period.

American	French	ISO
0.6	0,6	0.6
1,000	1 000	1 000
1,323,462.9	1 323 462,9	1 323 462.9

3. Keywords, Acronyms, and Definitions

For the purposes of this document, the following keywords, acronyms, and definitions apply.

3.1 Keywords

May: Indicates flexibility of choice with no implied preference.

May or may not: Indicates flexibility of choice with no implied preference.

Obsolete: Indicates that an item was defined in prior specifications but has been removed from this specification.

Optional: Describes features which are not required by the SFF specification. However, if any feature defined by the SFF specification is implemented, it shall be implemented as defined by the specification. Describing a feature as optional in the text is an informational callout to assist the reader.

Prohibited: Describes a feature, function, or coded value that is defined in a referenced specification to which this SFF specification makes a reference, where the use of said feature, function, or coded value is not allowed for implementations of this specification.

Reserved: Where the term is used for a signal on a connector contact, the function is set aside for future standardization. It is not available for vendor specific use. Where this term is used for bits, bytes, fields, and code values; the bits, bytes, fields, and code values are set aside for future standardization. The default value shall be zero. The originator is required to define a Reserved field or bit as zero, but the receiver should not check Reserved fields or bits for zero.

Restricted: Refers to features, bits, bytes, words, and fields that are set aside for other standardization purposes. If the context of the specification applies to the restricted designation, then the restricted bit, byte, word, or field shall be treated as a value whose definition is not in scope of this document, and is not interpreted by this specification.

Shall: Indicates a mandatory requirement. Designers are required to implement all such mandatory requirements to ensure interoperability with other products that conform to this specification.

Should: Indicates flexibility of choice with a strongly preferred alternative.

Vendor specific: Indicates something (e.g., a bit, field, code value) that is not defined by this specification. Specification of the referenced item is determined by the manufacturer and may be used differently in various implementations.

3.2 Acronyms and Abbreviations

EMLB: Early Mate Late Break

PCB: Printed Circuit Board

PF: Press Fit

PTH: Plated Through Hole

RA: Right Angle

RAND: Reasonable and Non-Discriminatory

RS: Returned Sidebands

SMT: Surface Mount Technology

3.3 Definitions

Alignment guides: A term used to describe features that pre-align the two halves of a connector interface before electrical contact is established. Other common terms include guide pins, guideposts, blind mating features, mating

1 features, alignment features, and mating guides.

2
3 **Basic (dimension):** The theoretical exact size, profile, orientation, or location of a feature. It is used as the basis
4 from which permissible variations are established by tolerances in notes or in feature control frames (GD&T).

5
6 **Connector:** Each half of an interface that, when joined together, establish electrical contact and mechanical
7 retention between two components. In this specification, the term connector does not apply to any specific gender;
8 it is used to describe the receptacle, the plug or the card edge, or the union of receptacle to plug or card edge.
9 Other common terms include connector interface, mating interface, and separable interface.

10
11 **Contact mating sequence:** A term used to describe the order of electrical contact established/ terminated during
12 mating/un-mating. Other terms include contact sequencing, contact positioning, mate first/break last, EMLB (early
13 mate late break) staggered contacts, and long pin/short pin.

14
15 **Contacts:** A term used to describe connector terminals that make electrical connections across a separable
16 interface.

17
18 **Datum:** A point, line, plane, etc. assumed to be exact for the purposes of computation or reference, as established
19 from actual features, and from which the location or geometric relationship of either feature is established.

20
21 **Fixed-side connector:** A term used to describe a connector that is terminated to a PCB. An example is shown
22 in Figure 3-13-13-1.

23
24 **Free-side connector:** A term used to describe connector terminals that make electrical connections across a
25 separable interface (e.g., the cable end). An example is shown in Figure 3-13-13-1.

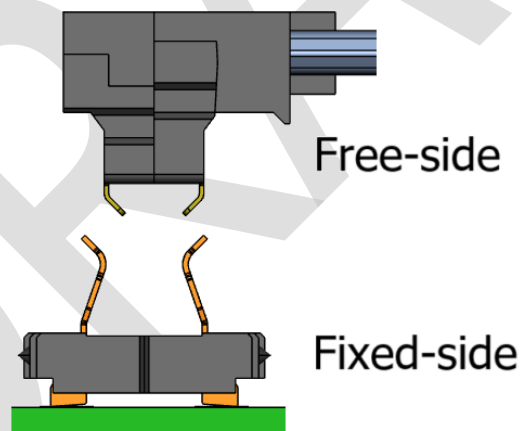

28
29 **Figure 3-1 Fixed-side and Free-side Connector Definition**

30
31 **Frontshell / Backshell:** A term used to describe the metallic part of a module that provides mechanical and
32 shielding continuity between the plug and receptacle. Other common terms include housing, snout, and metal
33 shroud.

34
35 **Module:** In this specification, module may refer to a plug assembly at the end of a copper (electrical) cable (passive
36 or active), an active optical cable assembly, an optical transceiver, or a loopback.

37
38 **Plug:** A term used to describe the connector that contains the penetrating contacts of the connector interface as
39 shown in Figure 3-23-23-2. Plugs typically contain stationary contacts. Other common terms include male
40 connector, pin connector, and card edge.

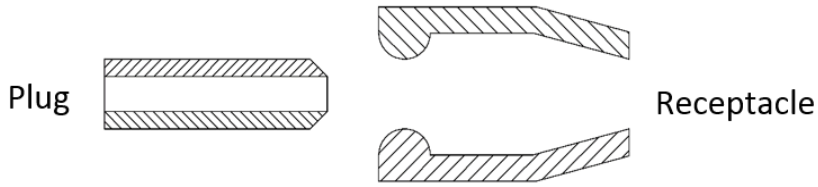

Figure 3-2 Plug and Receptacle Definition

Plated through hole termination: A term used to describe a termination style in which rigid pins extend into or through the PCB. Pins are soldered to keep the connector or cage in place. Other common terms include plated through hole (PTH).

Press fit: A term used to describe a termination style in which collapsible pins penetrate the surface of a PCB. Upon insertion, the pins collapse to fit inside the PCB's plated through holes. The connector or cage is held in place by the interference fit between the collapsed pins and the PCB.

Receptacle: A term used to describe the connector that contains the contacts that accept the plug contacts as shown in Figure 3-23-23-2. Receptacles typically contain spring contacts. Other common terms include female connector and socket connector.

Reference (dimension): A dimension provided for information or convenience. It has no tolerance and is not to be used for inspection or conformance. It can be calculated from other tolerance dimensions or can be found elsewhere on the drawing with a tolerance. If removed, it would have no impact on the defined object or the ability to reproduce it.

Right Angle: A term used to describe either a connector design where the mating direction is parallel to the plane of the printed circuit board upon which the connector is mounted or a cable assembly design where the mating direction is perpendicular to the bulk cable.

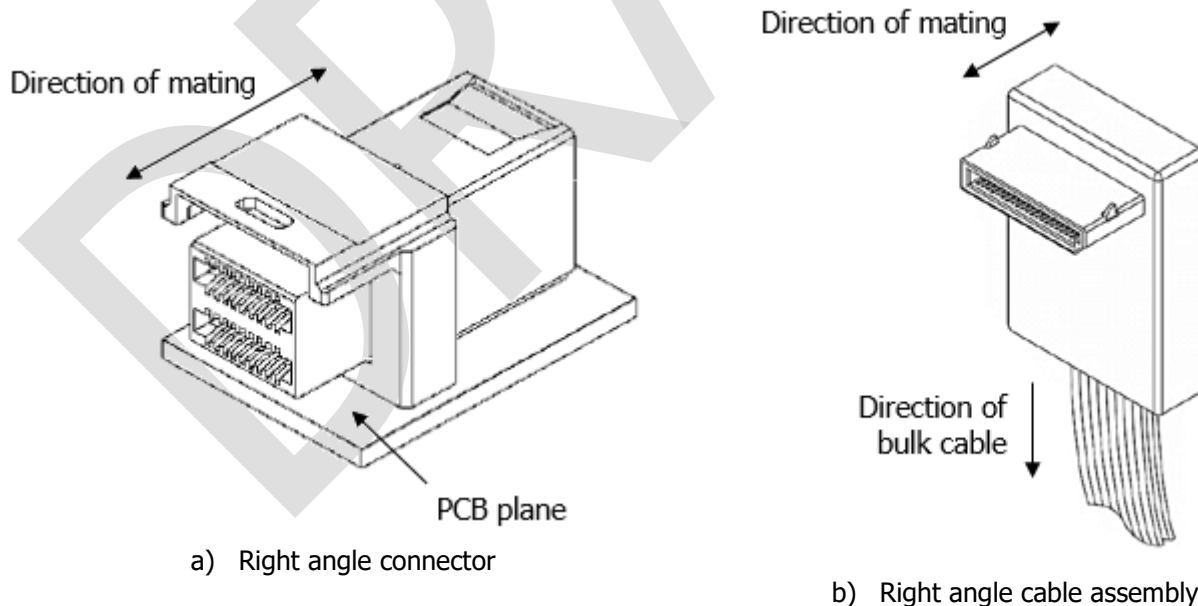

Figure 3-3 Right Angle Connector and Cable Assembly

Straddle mount: A term used to describe a termination style that uses surface mount termination points on both sides of a PCB.

- 1 **Straight:** A term used to describe a connector design where the mating direction is parallel to the bulk cable.
- 2
- 3 **Surface mount:** A term used to describe a termination style in which solder tails sit on pads on the surface of a
- 4 PCB and are then soldered to keep the connector or cage in place. Other common terms include surface mount
- 5 technology (SMT).
- 6
- 7 **Termination:** A term used to describe a connector’s non-separable attachment point such as a connector contact
- 8 to a bulk cable/ a cage to a PCB or flex circuit/ bulk cable to a PCB or flex circuit/ solder tail to PCB. Common PCB
- 9 terminations include surface mount technology (SMT), plated through hole (PTH), and press fit (PF). Common
- 10 cable terminations include insulation displacement contact (IDC), insulation displacement termination (IDT), wire
- 11 slots, solder, welds, crimps, and brazes.
- 12
- 13 **Vertical:** A term used to describe a connector design where the mating direction is perpendicular to the printed
- 14 circuit board upon which the connector is mounted.
- 15
- 16 **Wipe:** The distance a contact travels on the surface of its mating contact during the mating cycle as shown in
- 17 Figure 3-43-43-4.

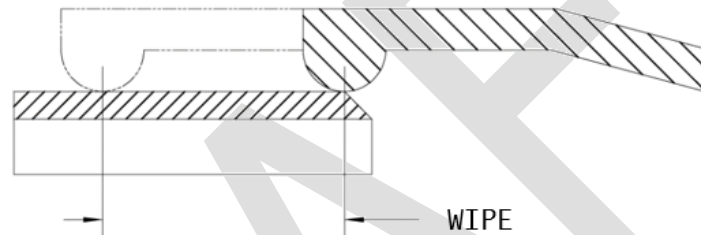

Figure 3-4 Wipe for a Continuous Contact

- 18
- 19
- 20

4. General Description

4.1 Configuration Overview/Descriptions

This document describes an interconnect system that includes a PCB mount receptacle connector and a cable plug. Figure 4-14-14-1 illustrates an overview of the interconnect system. The orthogonal receptacle connector accepts EDSFF devices on the left side and a cable plug on the right side. The connector directly passes through high-speed signals and some sidebands between the device and the cable plug. The connector routes power and some sidebands to a midplane. The sidebands may or may not be processed and returned to the connector. The connector then passes the sidebands to the cable plug. The other end of cable may be attached a SNIA SFF-TA-1016 connector to a host board.

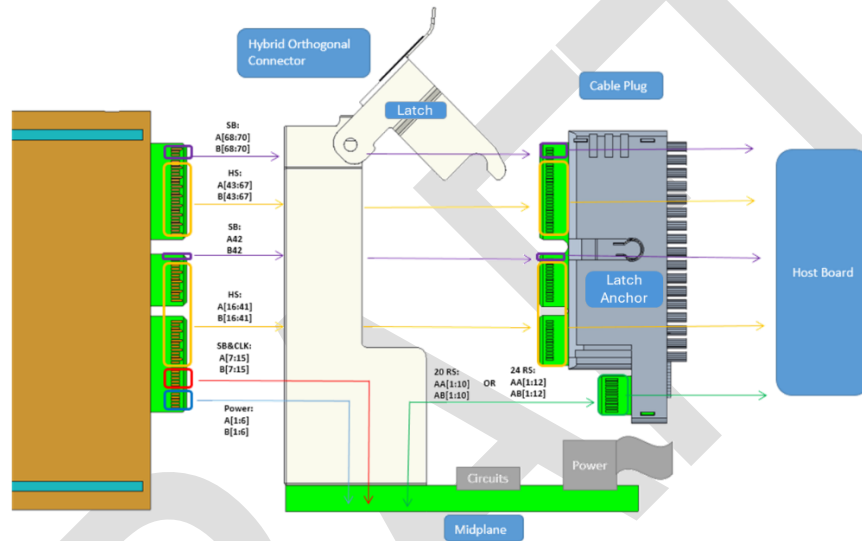

Figure 4-1 Hybrid Orthogonal EDSFF Connector System Overview

The hybrid orthogonal connector has 1C, 2C and 4C configurations. Each configuration may have cable plugs with 20 or 24 sideband pins returned from the midplane. Those pins are referred to RS (returned sidebands) in this document. 1C and 2C connectors have both standalone and ganged versions. Figure 4-24-24-2 shows configuration overview.

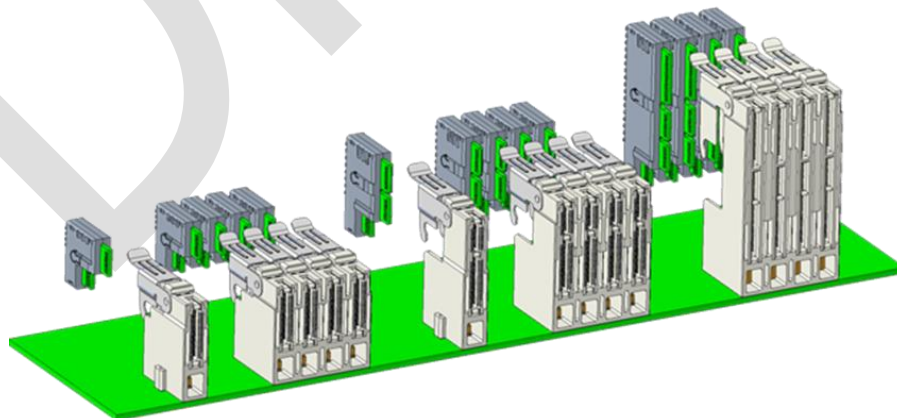
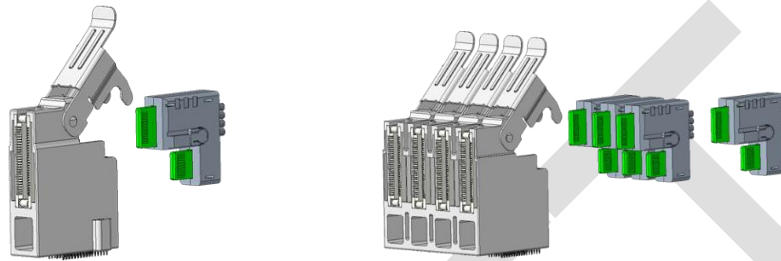

Figure 4-2 Connector Configuration Overview

1 The orthogonal connector defined in this specification has all high-speed ground pins joined together within the
2 connector body. Using the same connector type definition in SNIA SFF-TA-1002, the connector in this specification
3 is called "Type 2". The connector shall be clearly labeled. The location of the label is recommended in Appendix B.
4

5 **4.1.1 Connector Configuration 1 – 1C-RS20**

6 This configuration has 1C connector height and 20 sidebands returned from midplane.
7



8
9 **Figure 4-3 1C Hybrid Orthogonal Connector Receptacle and Plug with RS20**

11 **4.1.2 Connector Configuration 2 – 1C-RS24**

12 This configuration has 1C connector height and 24 sidebands returned from midplane.
13

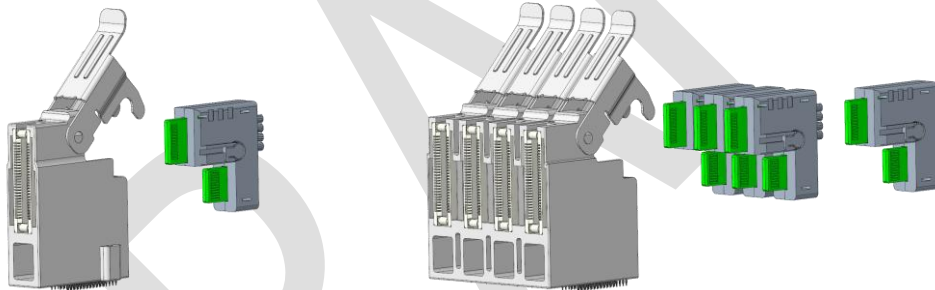

14
15 **Figure 4-4 1C Hybrid Orthogonal Connector Receptacle and Plug with RS24**

17 **4.1.3 Connector Configuration 3 – 2C-RS20**

18 This configuration has 2C connector height and 20 sidebands returned from midplane.
19

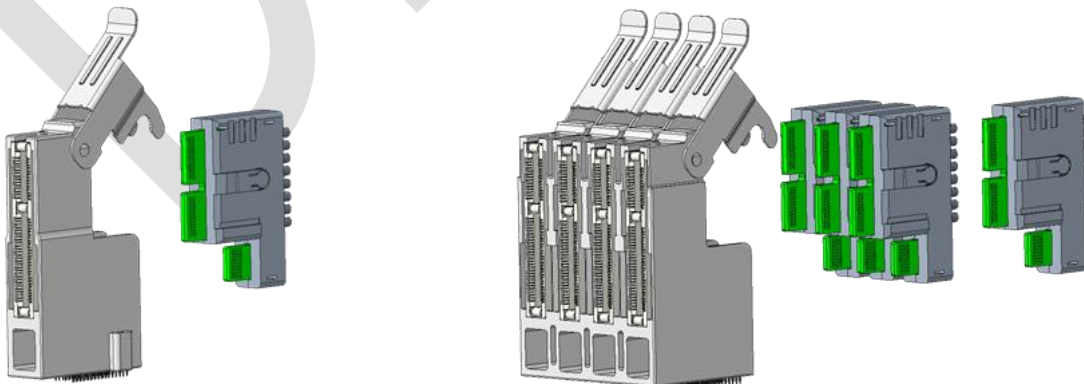

20
21 **Figure 4-5 2C Hybrid Orthogonal Connector Receptacle and Plug with RS20**
22

1 **4.1.4 Connector Configuration 4 – 2C-RS24**

2 This configuration has 2C connector height and 24 sidebands returned from midplane.

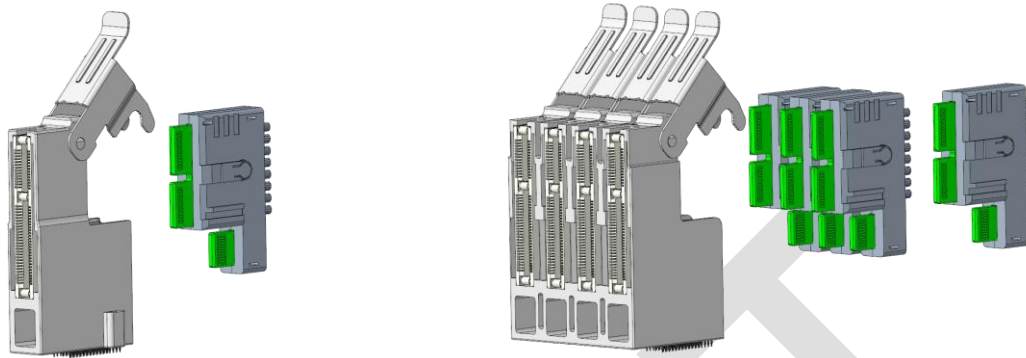

3
4 **Figure 4-6 2C Hybrid Orthogonal Connector Receptacle and Plug with RS24**

5
6 **4.1.5 Connector Configuration 5 – 4C-RS20**

7 This configuration has 4C connector height and 20 sidebands returned from midplane.

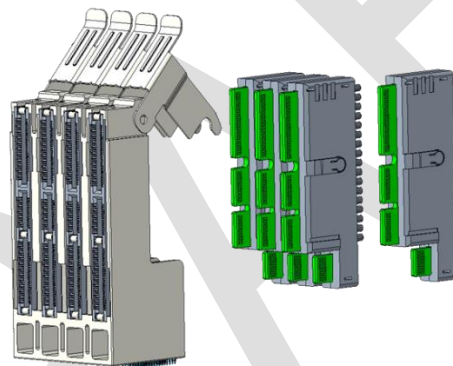

9
10 **Figure 4-7 4C Hybrid Orthogonal Connector Receptacle and Plug with RS20**

11
12 **4.1.6 Connector Configuration 6 – 4C-RS24**

13 This configuration has 4C connector height and 24 sidebands returned from midplane.

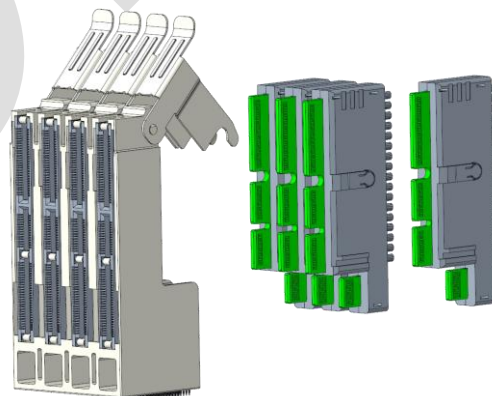

15
16 **Figure 4-8 4C Hybrid Orthogonal Connector Receptacle and Plug with RS24**

17

1
2
3
4
5
6
7

4.2 Contact Numbering

The pins or electrical contacts in the receptacle connectors are numbered as shown in Figure 4-94-94-9 and Figure 4-104-104-10. The pins or electrical contacts in the plug module are numbered as shown in Figure 4-114-114-11 and Figure 4-124-124-12. 1C, 2C and 4C connectors share the same footprint. The footprint pins are numbered as shown in Figure 4-134-134-13 and Figure 4-144-144-14.

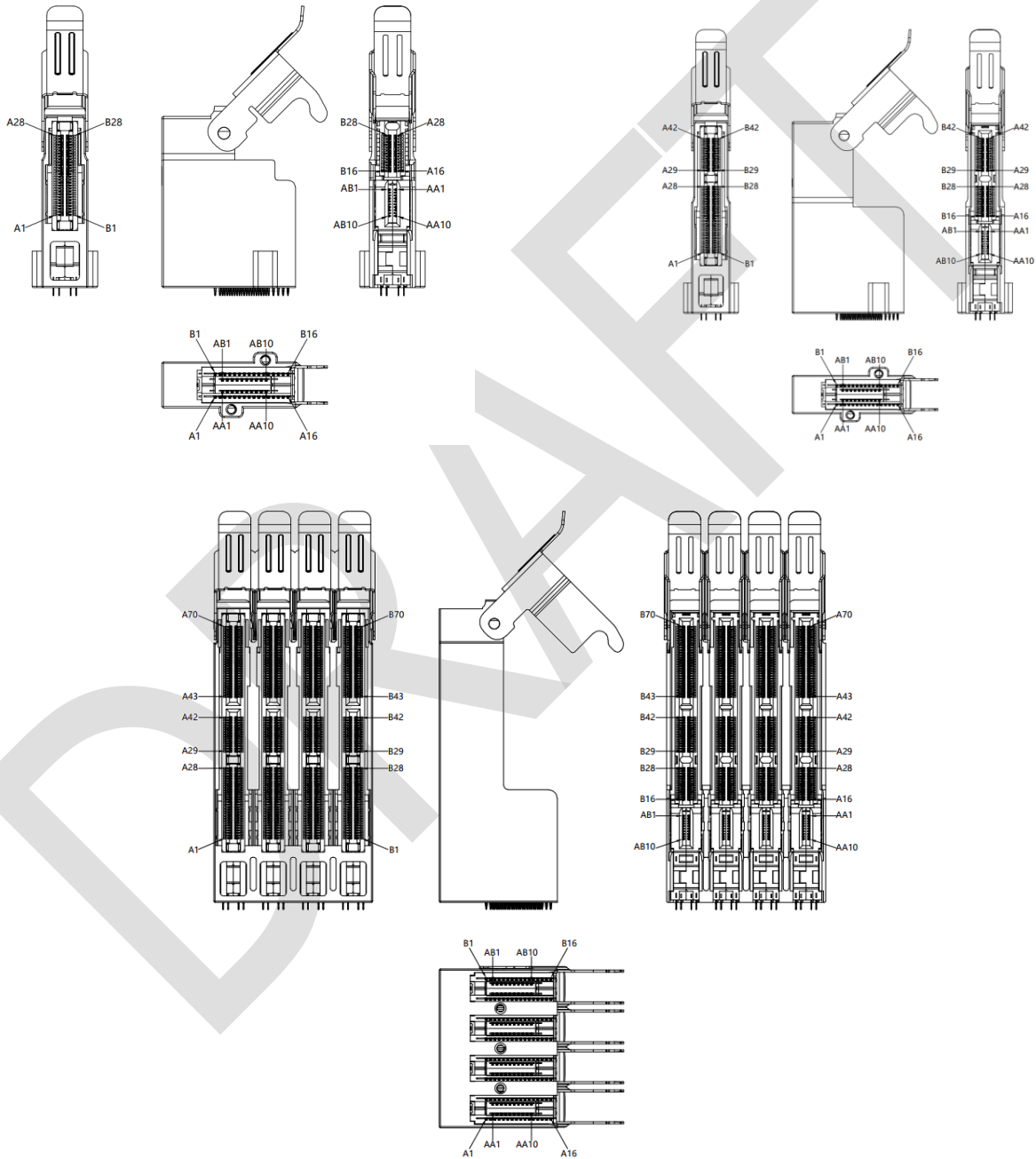

8
9

10
11
12
13

Figure 4-9 Contact Numbering of Receptacle Connectors with RS20

1

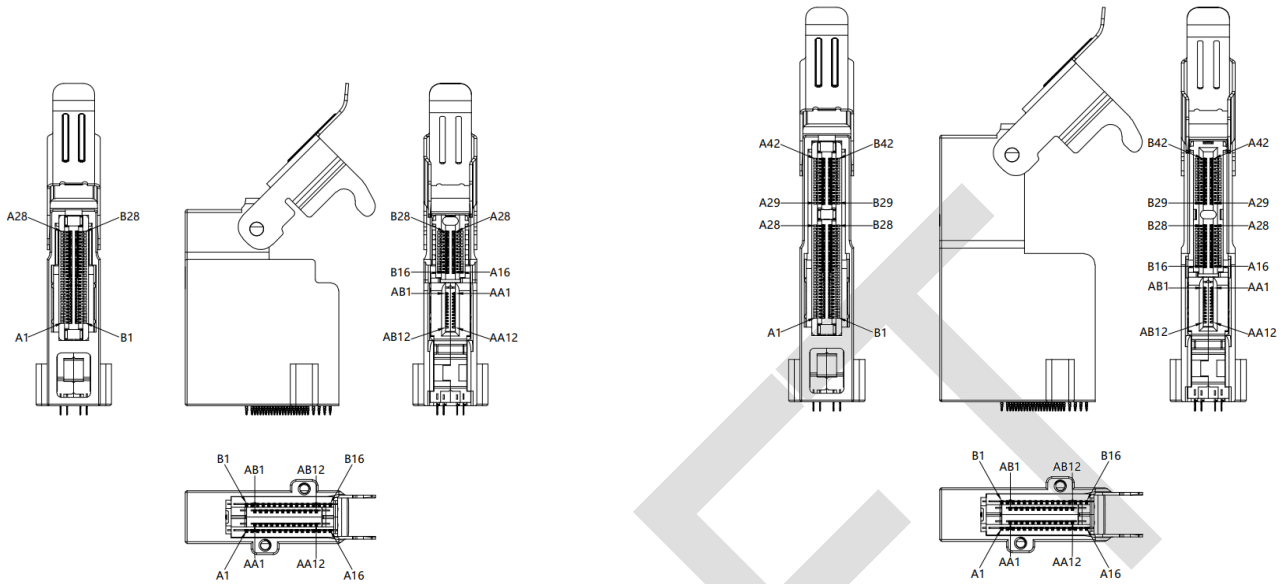

2
3

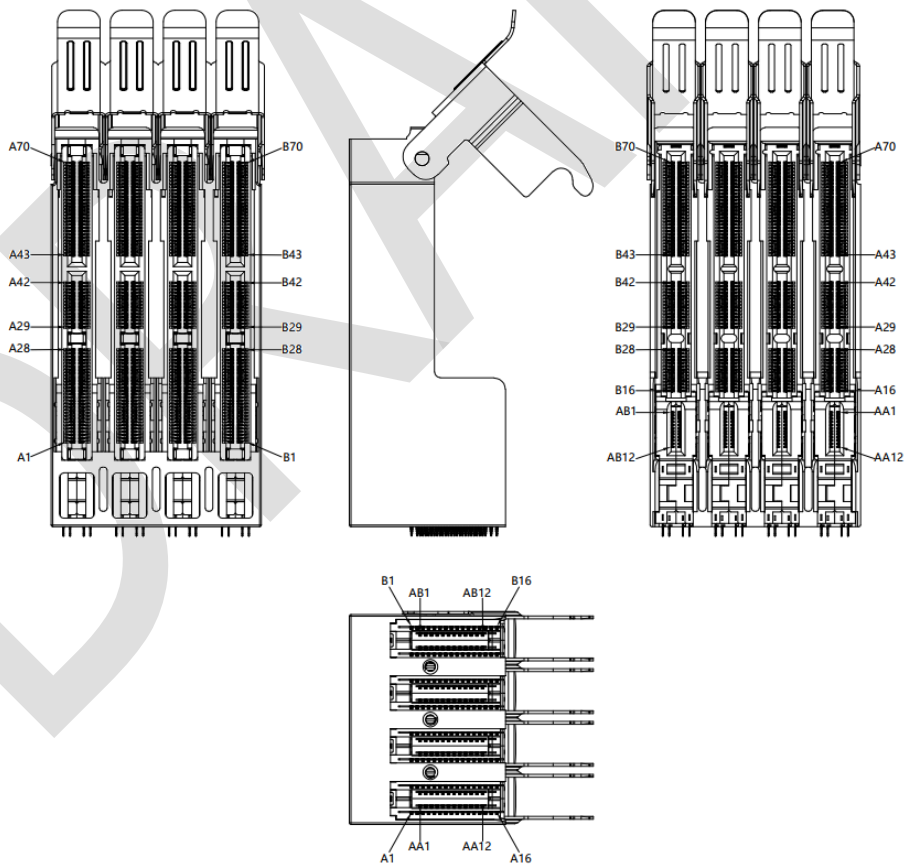

4
5
6
7

Figure 4-10 Contact Numbering of Receptacle Connectors with RS24

1

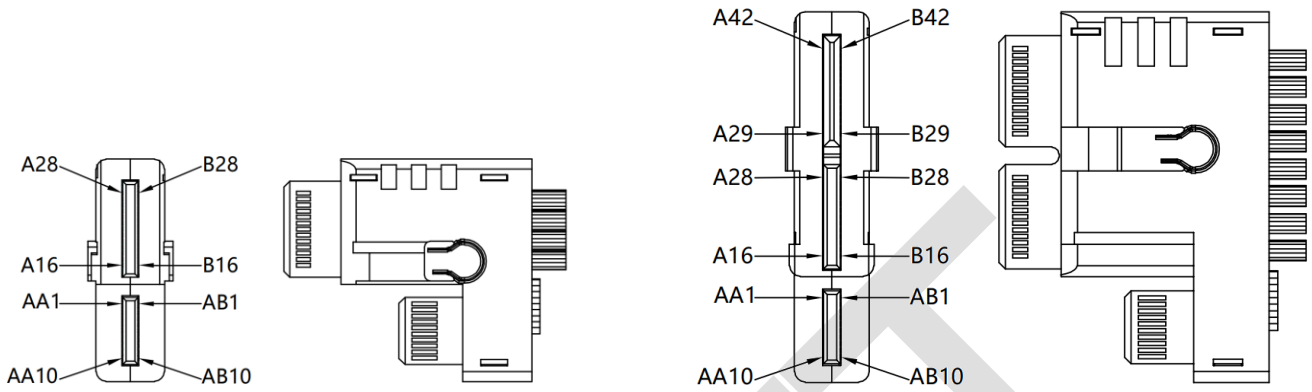

2

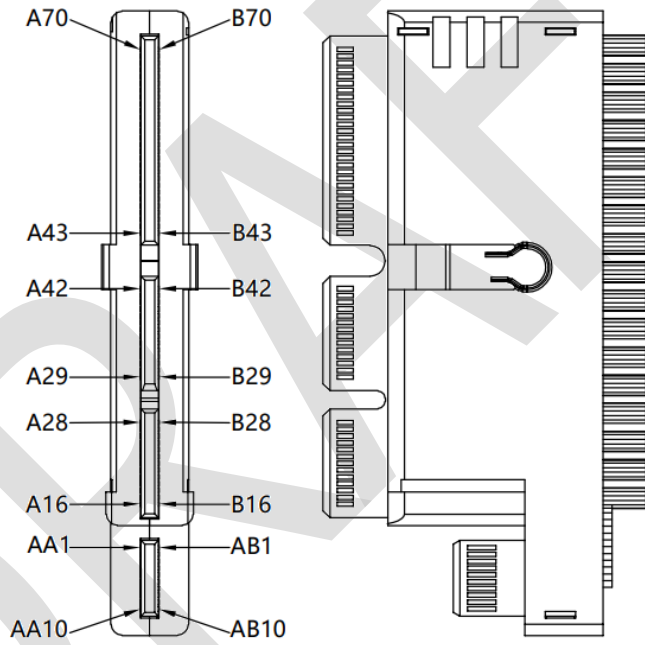

Figure 4-11 Contact Numbering of Plugs with RS20

3

4

5

6

7

8

9

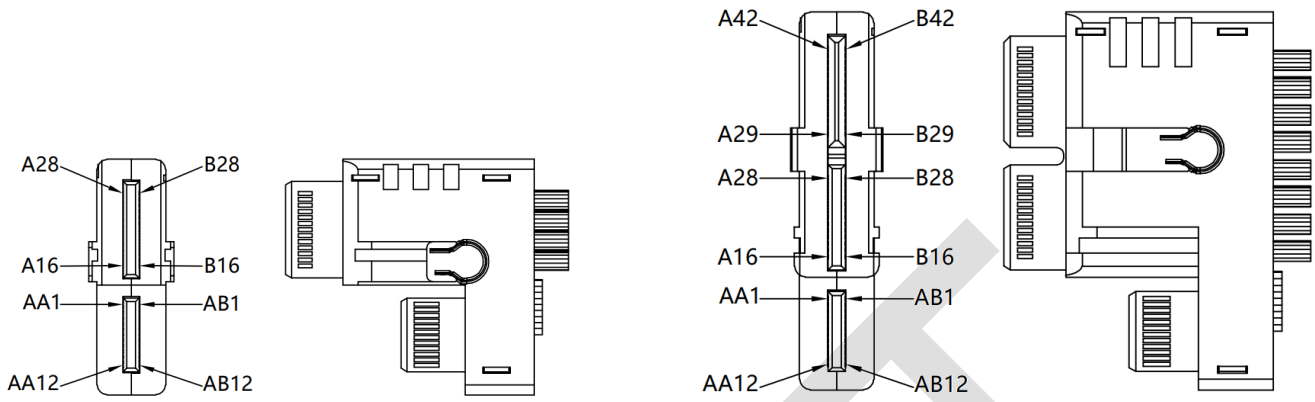

1

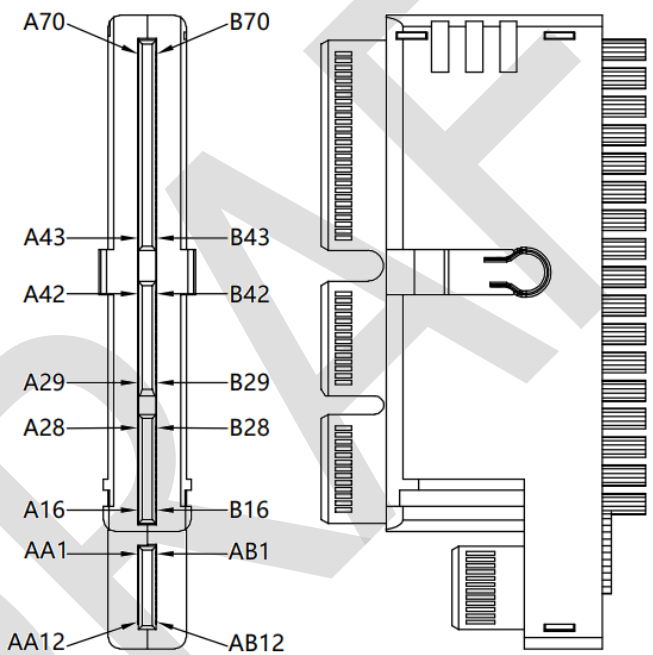

Figure 4-12 Contact Numbering of Plugs with RS24

2
3
4
5
6
7
8
9
10

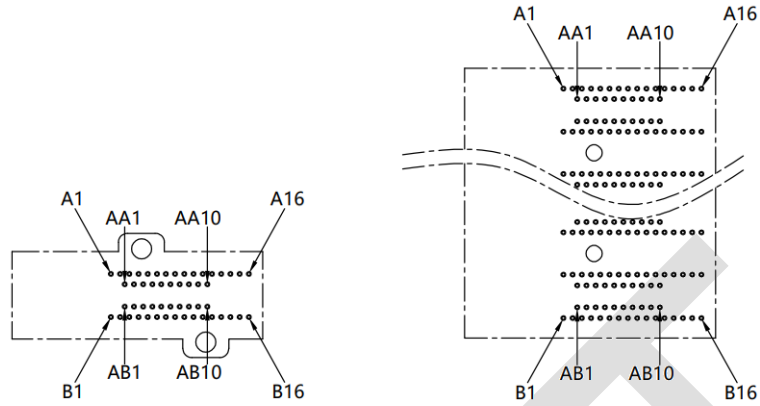

Figure 4-13 Pin Numbering of PCB Footprint with RS20

1
2
3
4
5
6

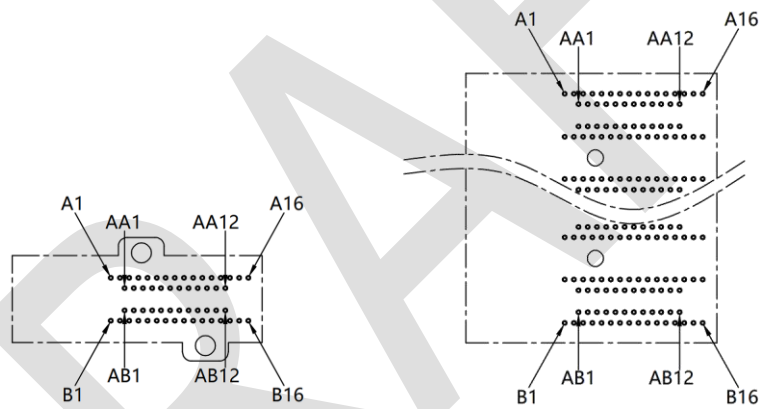

Figure 4-14 Pin Numbering of PCB Footprint with RS24

7
8
9

1
2
3
4
5
6
7
8
9
10
11
12
13
14
15
16
17

5. Connector Mechanical Specification

5.1 Overview

The mechanical drawings of all receptacle connector configurations are shown in this section. For ganged version, only a group of 4 connectors is shown in the drawing. It is easy to extrapolate it to other numbers of connectors in a group with the same pitch between connector to connector. 1x2, 1x3 and 1x4 are typical ganged usage cases.

Unless otherwise specified in the drawing, the following tolerances shall apply by default:

- a. Dimension with one decimal, default tolerance +/- 0.25mm
- b. Dimension with one decimal, default tolerance +/- 0.20mm
- c. Dimension with one decimal, default tolerance +/- 0.10mm
- d. Angular dimension, default tolerance +/- 0.5°

5.2 Mechanical Description: Hybrid Orthogonal 1C Connector

5.2.1 Hybrid Orthogonal 1C-RS20 Connector

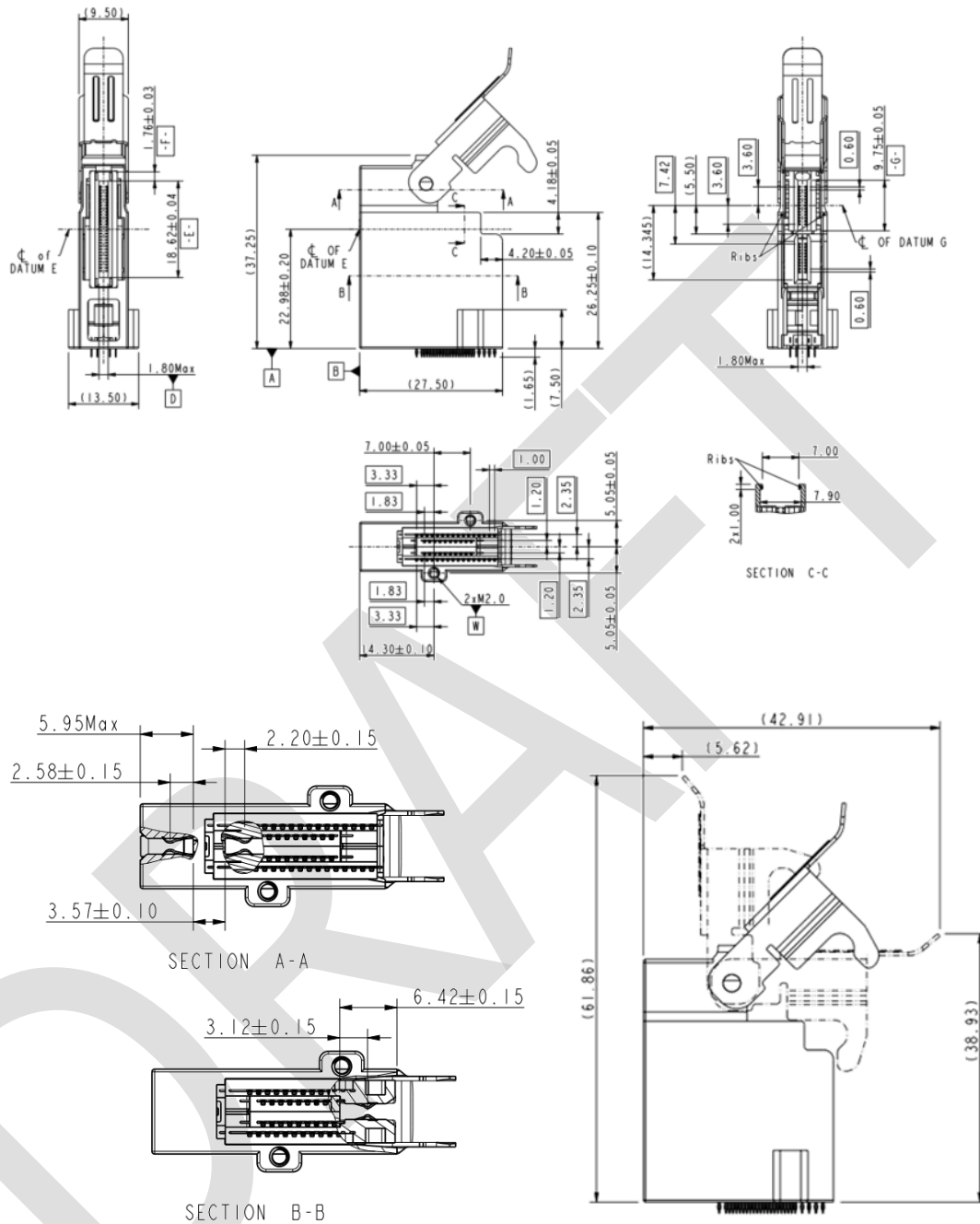

Figure 5-1 Standalone 1C-RS20 Connector

1
2

3
4
5
6

1
2

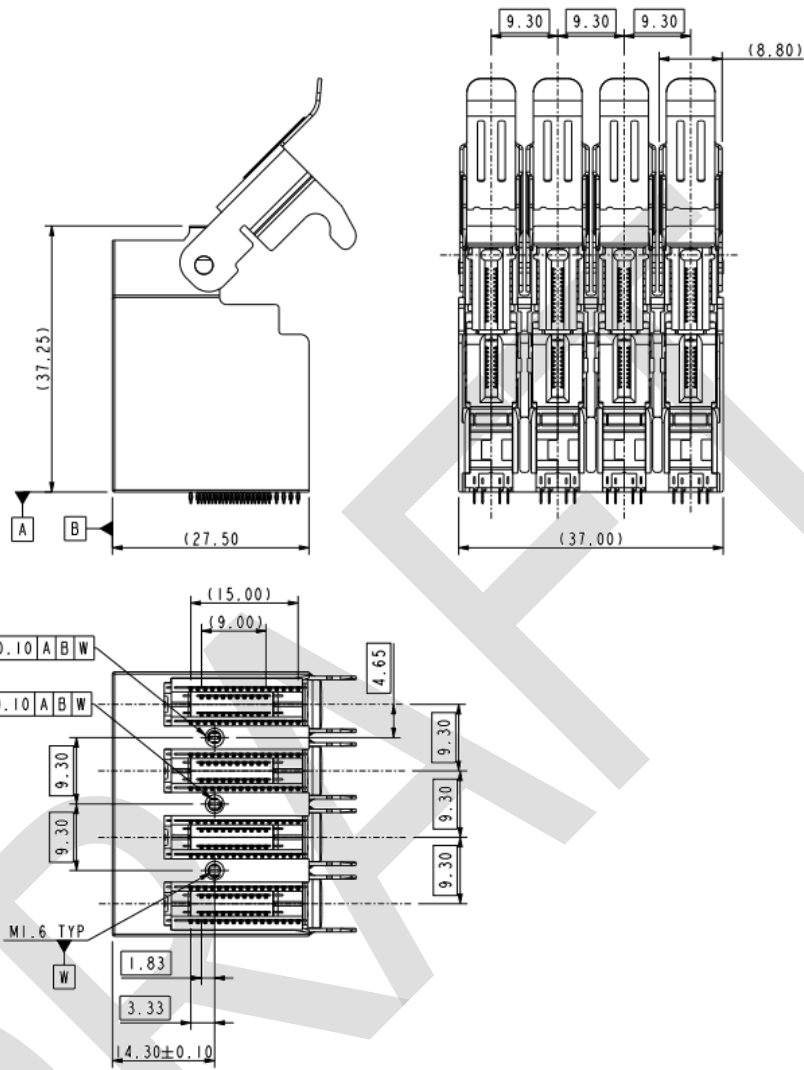
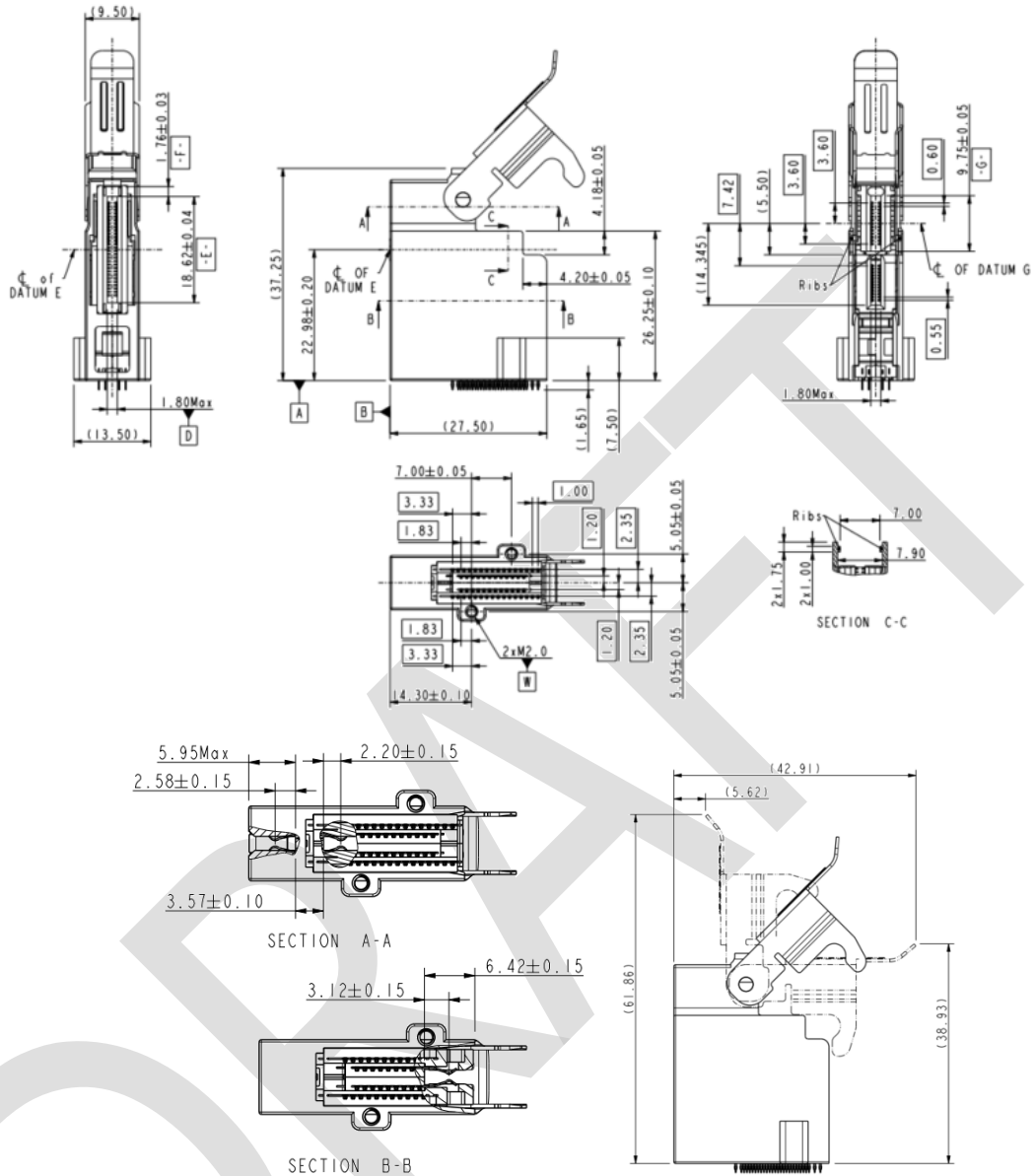

Figure 5-2 Ganged 1C-RS20 Connector

5.2.2 Hybrid Orthogonal 1C-RS24 Connector

3
4
5
6
7
8
9
10
11
12



1

2
3
4
5
6
7
8

Figure 5-3 1C-RS24 Connector

1
2

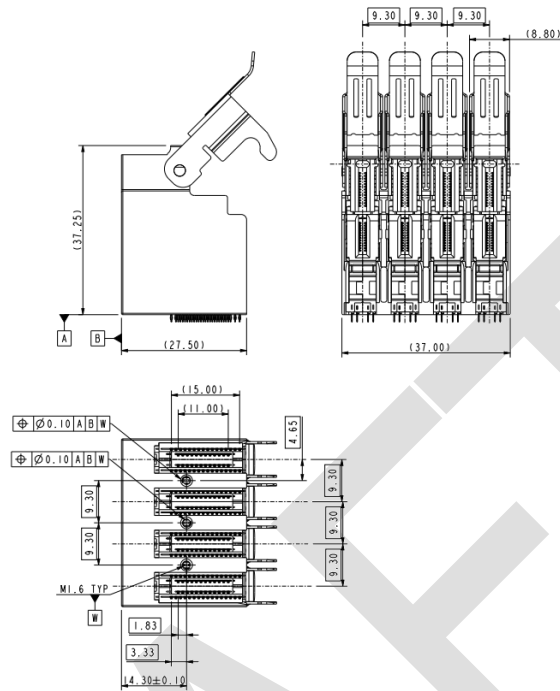
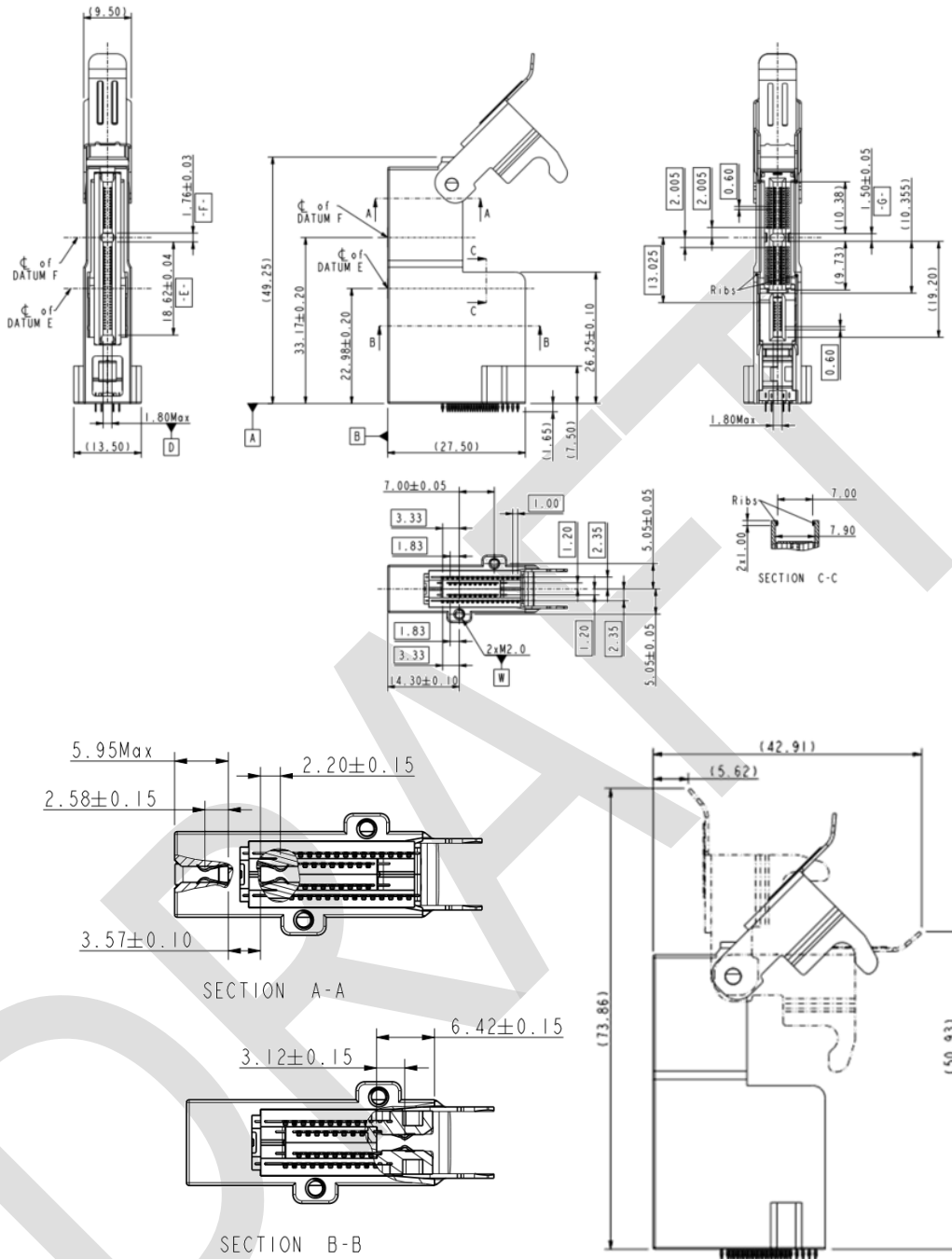

Figure 5-4 Ganged 1C-RS24 Connector

3
4
5
6
7
8
9
10
11
12
13
14
15
16
17

5.3 Mechanical Description: Hybrid Orthogonal 2C Connector

5.3.1 Hybrid Orthogonal 2C-RS20 Connector



1
2

3
4
5
6
7
8

Figure 5-5 2C-RS20 Connector

1
2

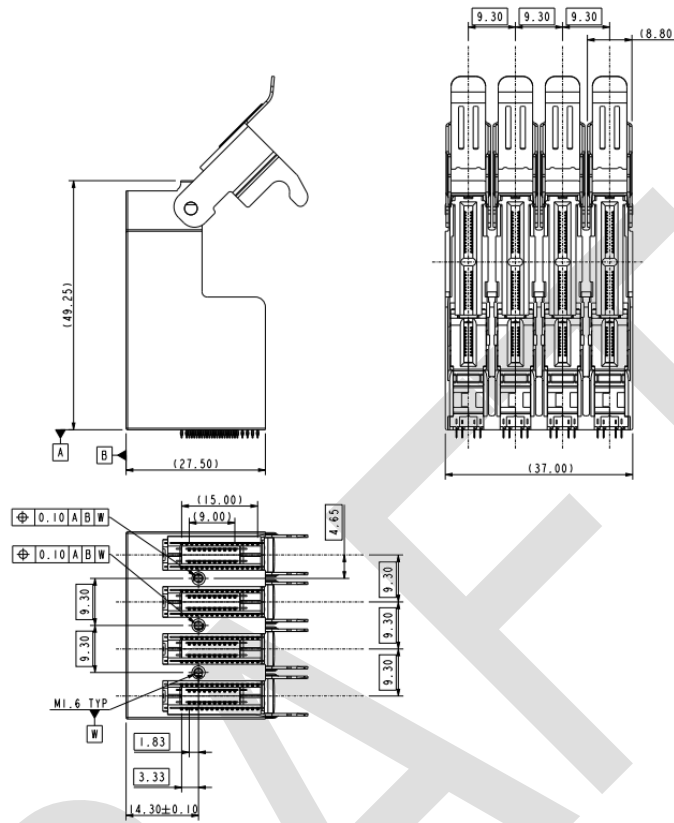
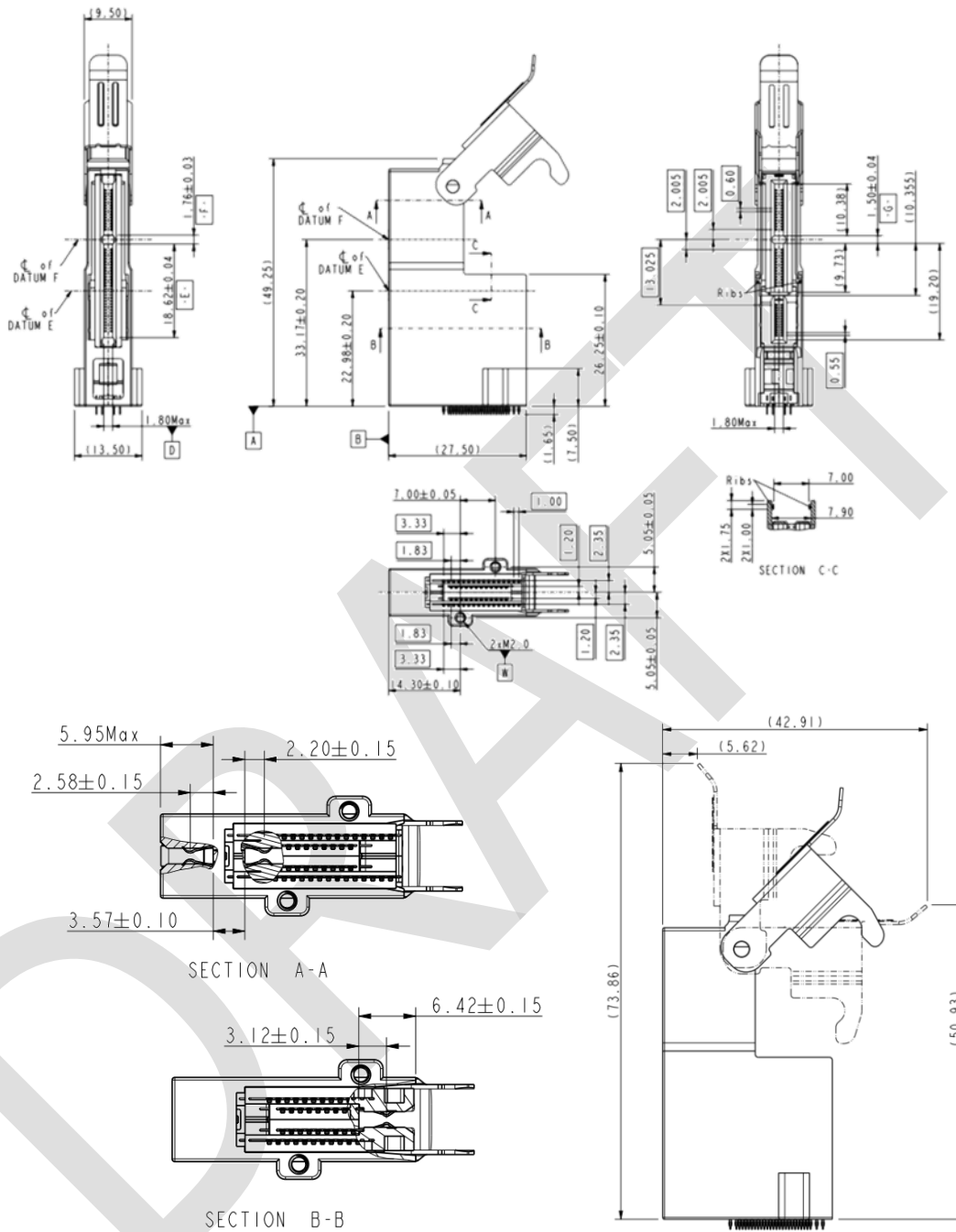

Figure 5-6 Ganged 2C-RS20 Connector

3
4
5
6
7
8
9
10
11
12
13
14
15
16
17
18
19
20
21
22
23
24
25
26

1 **5.3.2 Hybrid Orthogonal 2C-RS24 Connector**

2



3

4

5

6

7

Figure 5-7 2C-RS24 Connector

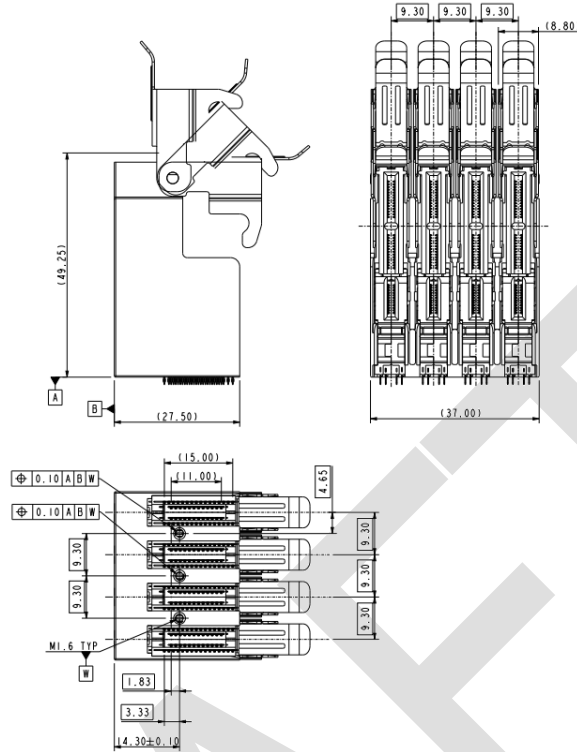

Figure 5-8 2C-RS24 Connector

1
2
3
4
5
6
7
8
9

5.4 Mechanical Description: Hybrid Orthogonal 4C Connector

5.4.1 Hybrid Orthogonal 4C-RS20 Connector

10
11
12
13

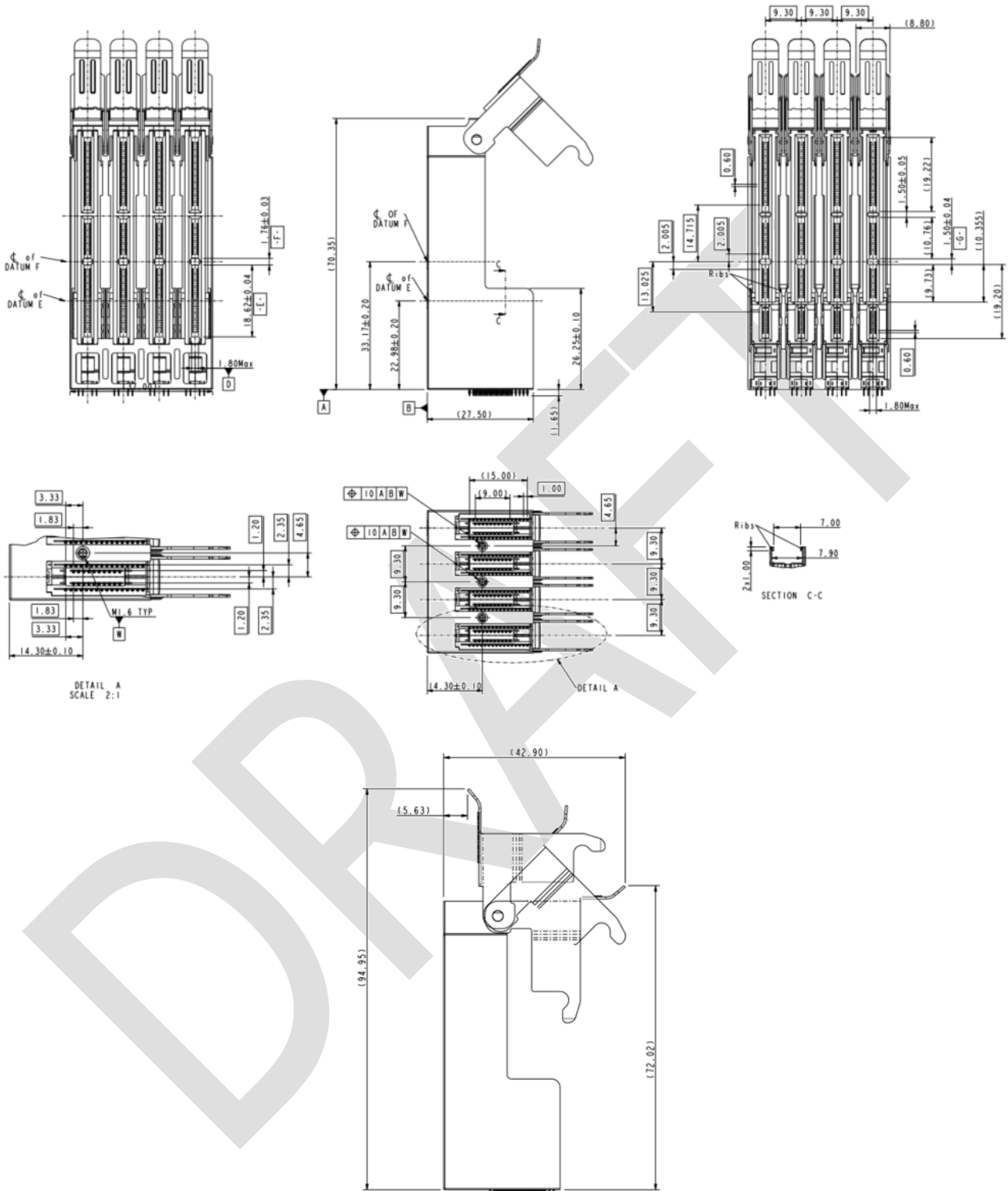

1
2

3
4
5
6
7
8

Figure 5-9 Ganged 4C-RS20 Connector

1
2
3
4
5
6
7

5.4.2 Hybrid Orthogonal 4C-RS24 Connector

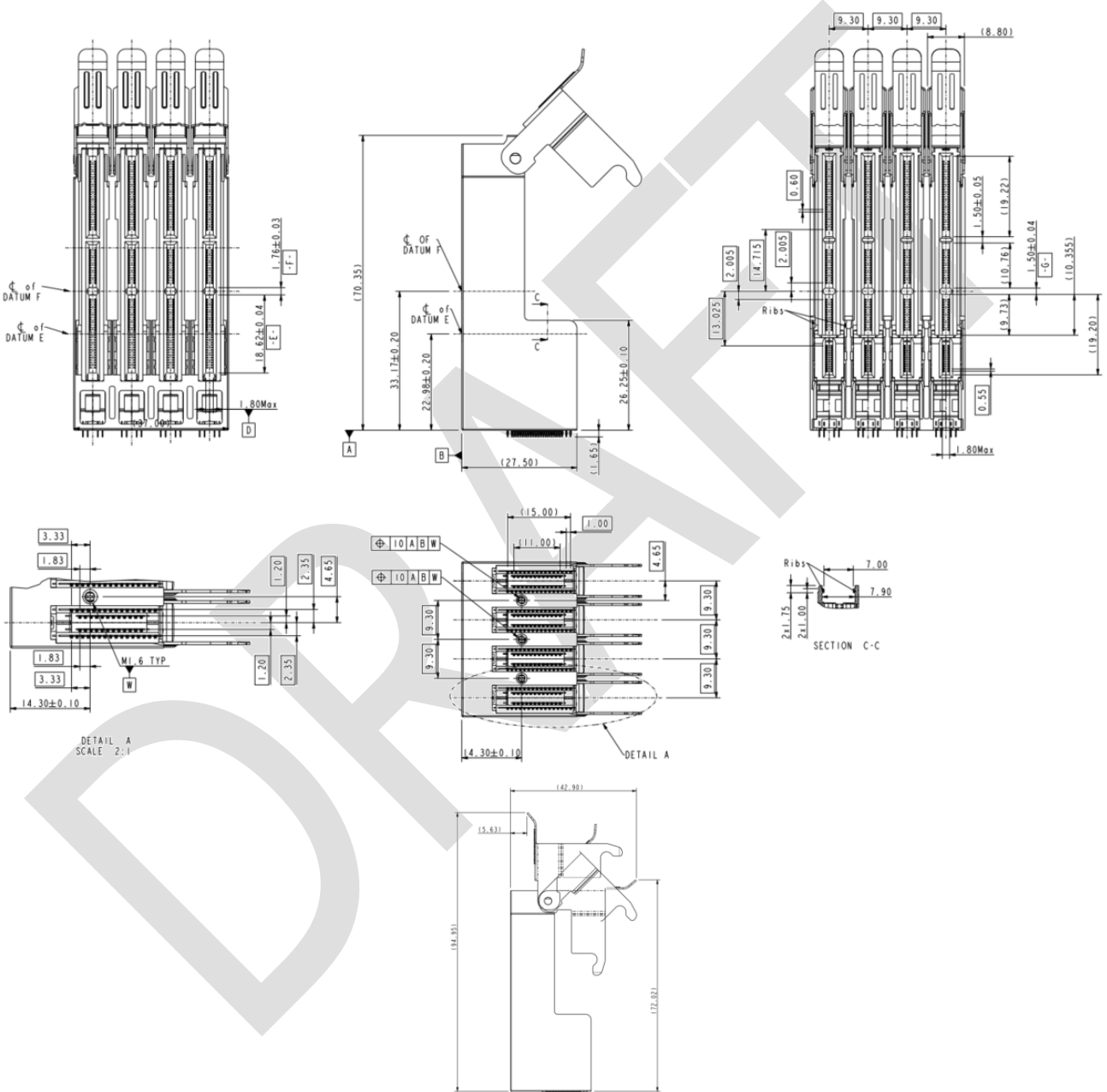

8

Figure 5-10 Ganged 4C-RS24 Connector

9
10
11
12
13

6. Module Mechanical Specification

6.1 Overview

The mechanical drawings of all plug module connector configurations are shown in this section.

Unless otherwise specified in the drawing, the following tolerances shall apply by default:

- a. Dimension with one decimal, default tolerance +/- 0.25mm
- b. Dimension with one decimal, default tolerance +/- 0.20mm
- c. Dimension with one decimal, default tolerance +/- 0.10mm
- d. Angular dimension, default tolerance +/- 0.5°

6.2 Mechanical Description: 1C Plug Modules

6.2.1 1C-RS20 Plug Module

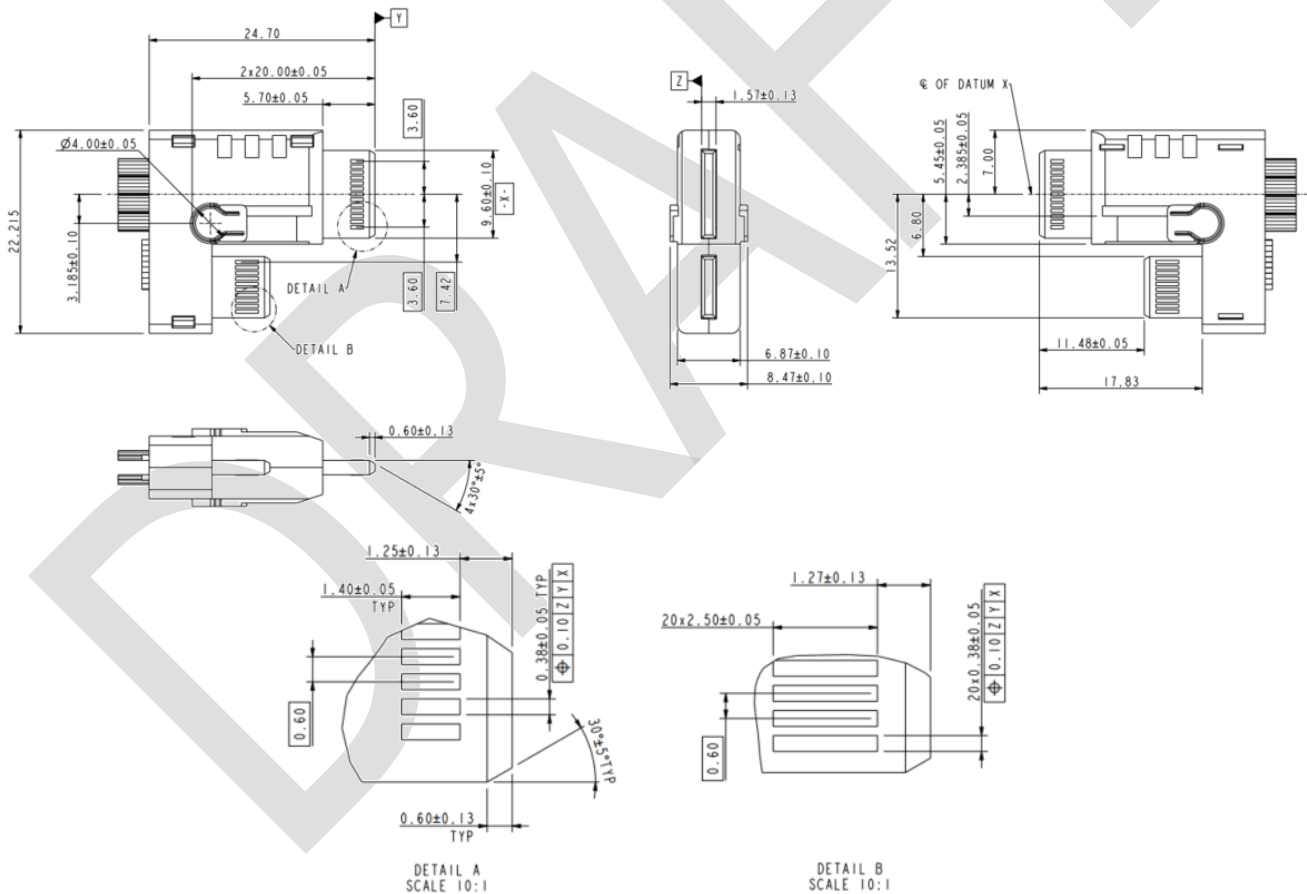
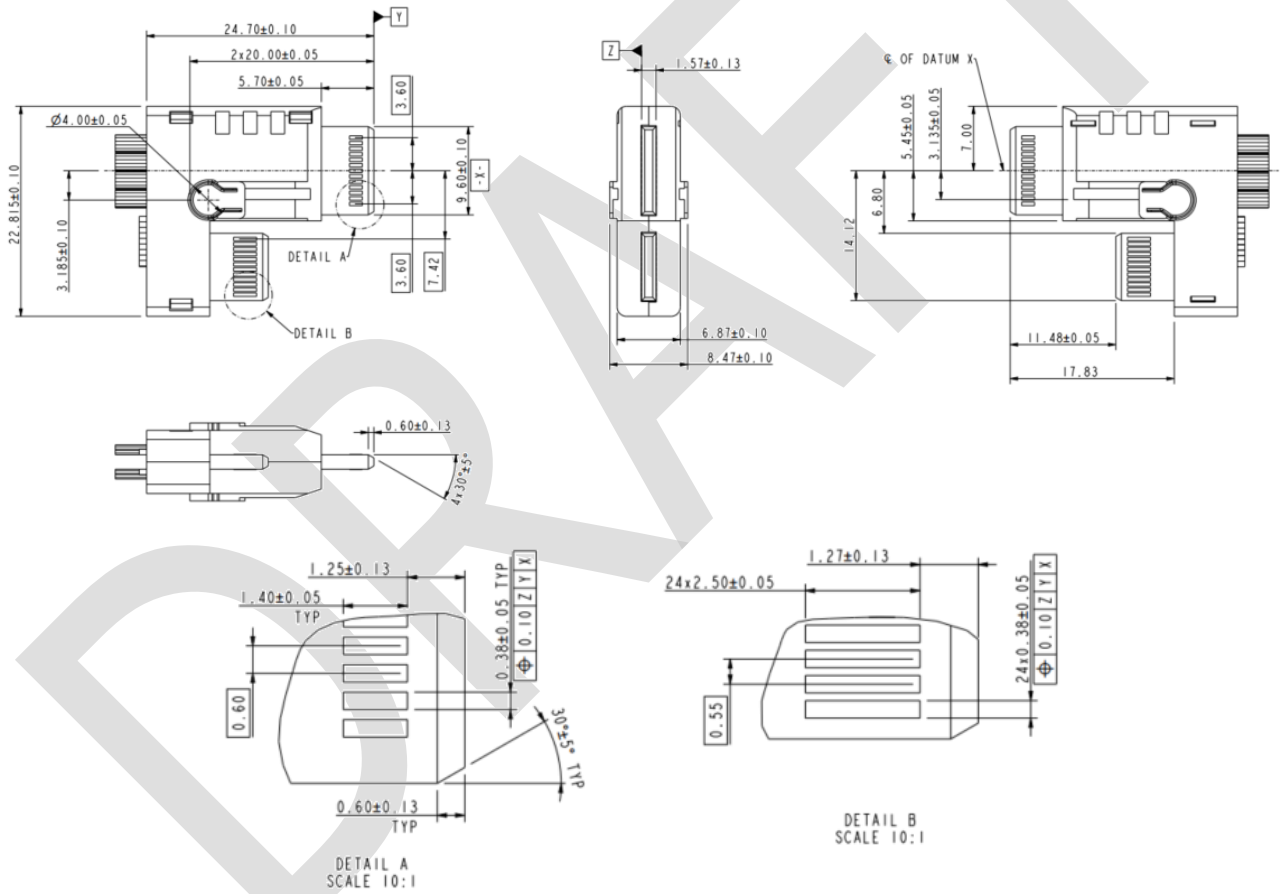

Figure 6-1 1C-RS20 Plug Module

1
2
3
4
5
6
7
8
9
10
11
12
13
14
15

6.2.2 1C-RS24 Plug Module



16

17
18
19
20
21
22
23
24
25

Figure 6-2 1C-RS24 Plug Module

1
2
3
4
5
6
7
8
9
10
11
12
13
14
15
16
17
18
19
20
21
22
23

6.3 Mechanical Description: 2C Plug Modules

6.3.1 2C-RS20 Plug Module

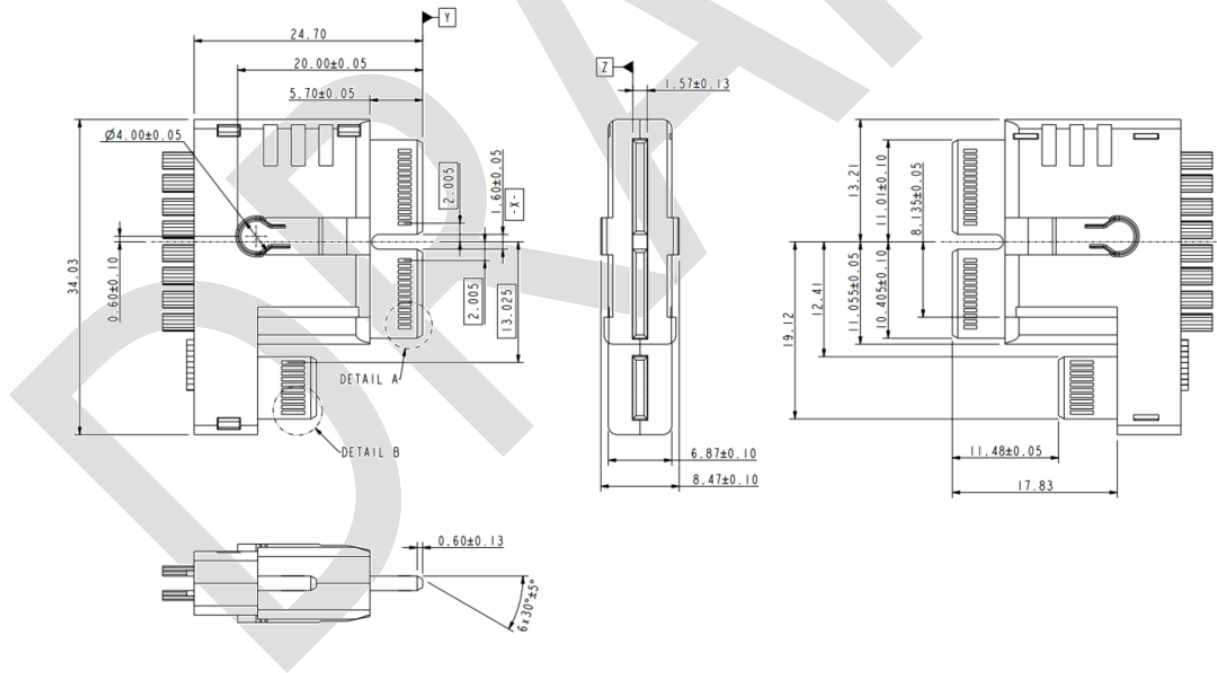

24

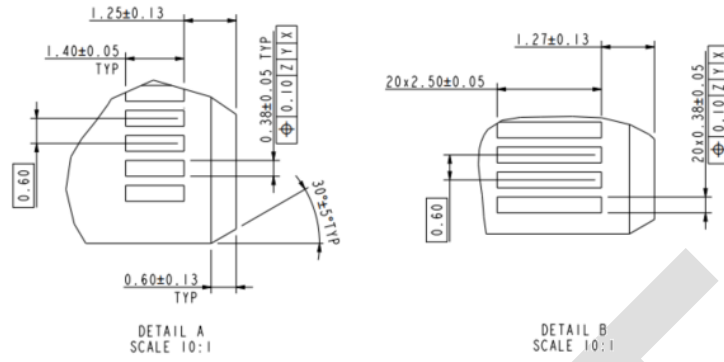
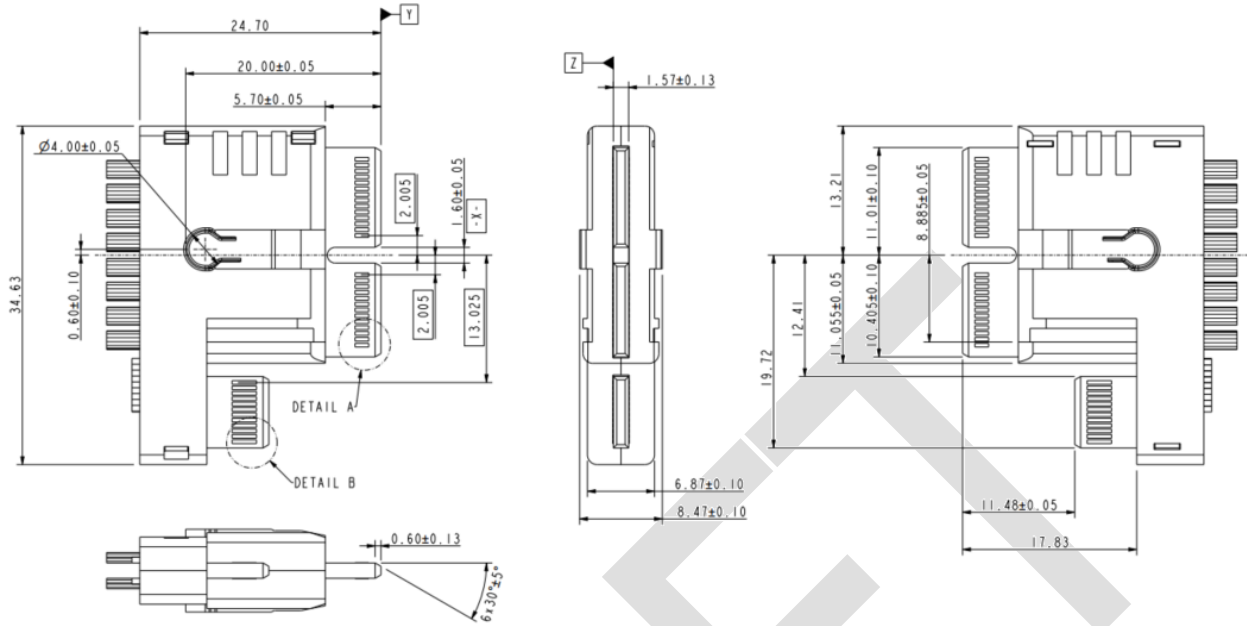

Figure 6-3 2C-RS20 Plug Module

1
2
3
4
5
6
7
8
9
10
11
12
13
14
15
16
17
18
19
20
21
22

6.3.2 2C-RS24 Plug Module



1
2

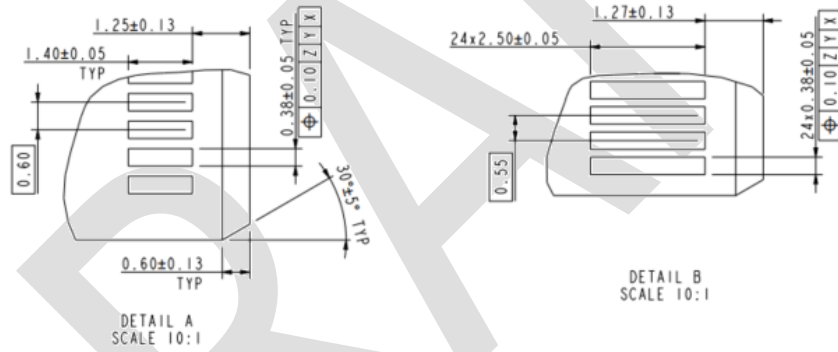

3
4
5
6
7
8
9

Figure 6-4 2C-RS24 Plug Module

6.4 Mechanical Description: 4C Plug Modules

6.4.1 4C-RS20 Plug Module

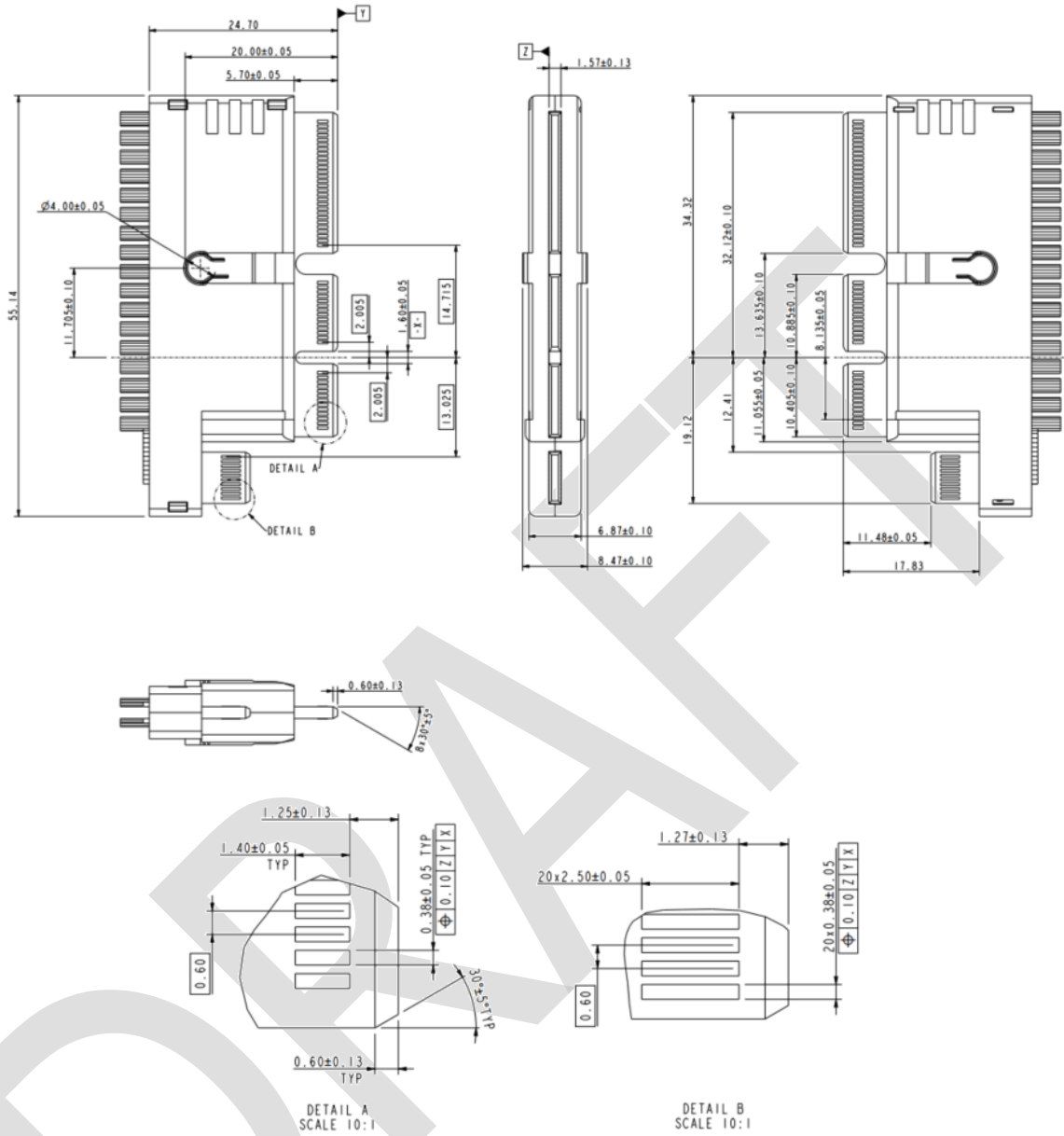

1
2

3
4
5
6

Figure 6-5 4C-RS20 Plug Module

1 6.4.2 4C-RS24 Plug Module

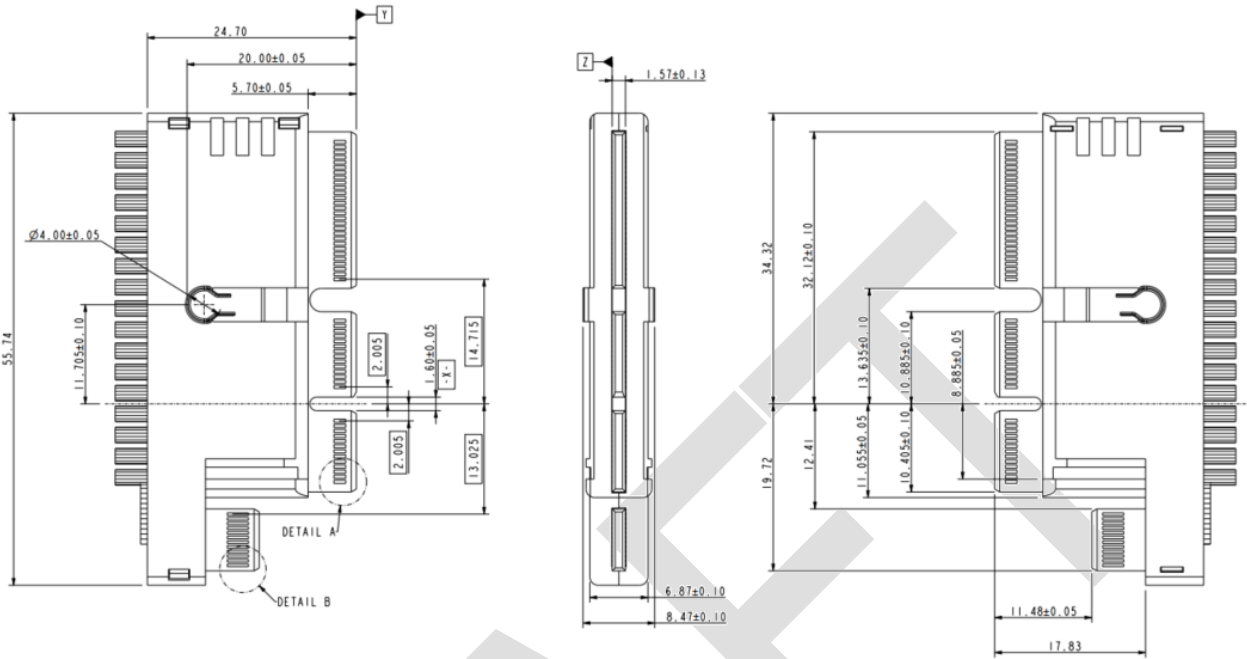

2

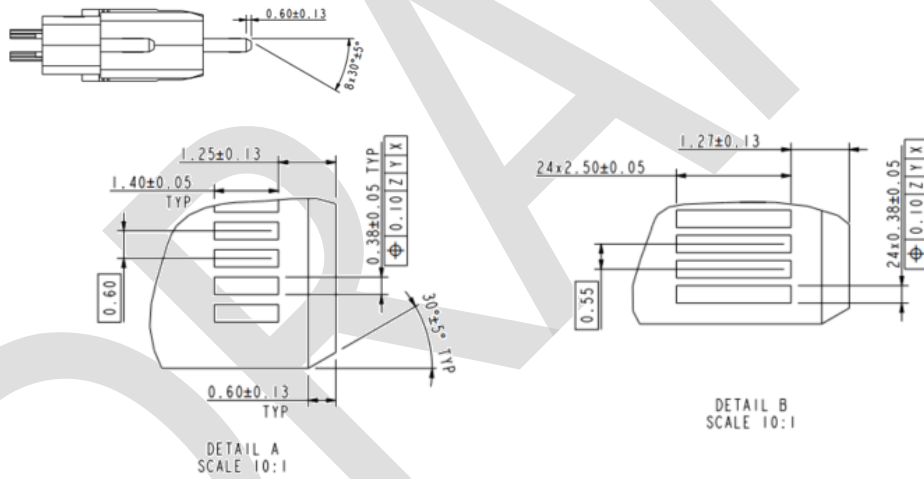

3
4
5
6
7
8
9

Figure 6-6 4C-RS24 Plug Module

7. Test Requirements and Methodologies (TS-1000, etc.)

7.1 Performance Tables

EIA-364-1000 (TS-1000) shall be used to define the test sequences and procedures for evaluating the connector system described in this document. Where multiple test options are available, the manufacturer shall select the appropriate option where not previously specified. The selected procedure should be noted when reporting data. If there are conflicting requirements or test procedures between EIA-364 procedures and those contained within this document, this document shall be considered the prevailing authority.

Unless otherwise specified, procedures for sample size, data, and collection to be followed as specified in EIA-364-1000. See EIA-364-1000 Annex B for objectives of tests and test groups.

Table 7-1 summarizes the performance criteria that are to be satisfied by the connector described in this document. Most performance criteria are validated by EIA-364-1000 testing, but this test suite leaves some test details to be determined. To ensure that testing is repeatable, these details are identified in Table 7-2. Finally, testing procedures used to validate any performance criteria not included in EIA-364-1000 are provided in Table 7-3.

Table 7-1 Form Factor Performance Requirements

Performance Parameters	Description/ Details	Requirement
Mechanical/ Physical Requirements		
Plating Type	Plating type on connector contacts	Precious
Surface Treatment	Surface treatment on connector contacts	Non-lubricated
Wipe length	Designed distance a contact traverses over a mating contact surface during mating and resting at a final position	Greater than 0.127 mm
Rated Durability Cycles	The expected number of durability cycles a component is expected to encounter over the course of its life	Connector/ cage: 200 cycles
Latched Mating Force*	Amount of force needed to mate a module with a connector when latches are deactivated	1.1 N Max/contact pair
Unlatched Unmating Force*	Amount of force needed to separate a module from a connector when latches are deactivated	0.1 N Min/contact pair
Latch Retention*	Amount of force the latching mechanism can withstand	100 N min
Wrenching Strength*	Amount of force in various directions the product can withstand while mated	25 N MIN for each axis direction
Environmental Requirements		
Field Life	The expected service life for a component	10 years
Field Temperature	The expected service temperature for a component	0°C to +65°C
Storage Temperature*	The expected storage temperature for a component when not in use	-20°C to +80°C
Storage Humidity*	The maximum expected storage humidity for a component when not in use	80% Relative Humidity

Table 7-1 Form Factor Performance Requirements

Performance Parameters	Description/ Details	Requirement
Electrical Requirements		
Current*	Maximum current to which a contact is exposed in use	0.5 A per contact max 1.1 A per power contact max
Operating Rating Voltage	Maximum voltage to which a contact is exposed in use	29 V DC per contact max
NOTE: Performance criteria denoted with stars (*) are not validated by EIA-364-1000 testing. Refer to Table 7-3 for test procedures and pass/fail criteria.		

- 1 Table 7-2 describes the details necessary to perform the tests described in the EIA-364-1000 test sequences.
- 2 Testing shall be done in accordance with EIA-364-1000 and the test procedures it identifies in such a way that
- 3 the parameters/ requirements defined in Table 7-1 are met. Any information in this table supersedes EIA-364-
- 4 1000.

Table 7-2 EIA-364-1000 Test Details

Test	Test Descriptions and Details	Pass/ Fail Criteria
Mechanical/ Physical Tests		
Durability (preconditioning)	EIA-364-09 To be tested with connector, cage, and module (Latches should not be locked)	No evidence of physical damage
Durability (see Note 1)	EIA-364-09 To be tested with connector, cage, and module (Latches should not be locked out per EIA-364-1000)	No visual damage to mating interface or latching mechanism
Environmental Tests		
Mixed Flowing Gas (see Note 2)	EIA-364-65 Class II See Table 4.1 in EIA-364-1000 for exposure times Test option Per EIA-364-1000: 4	No intermediate test criteria
Electrical Tests		
Low Level Contact Resistance (see Note 3)	EIA-364-23 20 mV DC max, 100 mA max To include wire termination or connector-to-board termination	20 mΩ max change from baseline
Dielectric Withstanding Voltage	EIA-364-20 Method B 300 VDC minimum for 1 minute Applied voltage may be product / application specific	No defect or breakdown between adjacent contacts -AND- 1 mA max Leakage Current
NOTES:		
<ol style="list-style-type: none"> 1. If the durability requirement on the connector is greater than that of the module, modules may be replaced after their specified durability rating. 2. Test option, temperature, duration must be reported. 3. The first low level contact resistance reading in each test sequence is used to determine a baseline measurement. Subsequent measurements in each sequence are measured against this baseline. 		

- 5
- 6

1 Table 7-3 describes the testing procedures necessary to validate performance criteria not validated by EIA-364-
 2 1000 testing. The tests are to be performed in such a way that the parameters/ requirements defined in Table 7-1
 3 are met.

Table 7-3 Additional Test Procedures

Test	Test Descriptions and Details	Pass/ Fail Criteria
Mechanical/ Physical Tests		
Latched Mating Force	EIA-364-13 To be tested with cage, connector, and module without heat sinks Latching mechanism deactivated (locked out)	Refer to Table 7-1 -AND- No physical damage to any components
Latched Unmating Force	EIA-364-13 To be tested with cage, connector, and module without heat sinks Latching mechanism deactivated (locked out)	
Latch Retention	EIA-364-13 To be tested with cage, connector, and module without heat sinks Latching mechanism engaged (not locked out)	
Environmental Tests		
Storage Temperature	EIA-364-32 Method A, Test Condition 1, Duration 4 Use min and max Field Temperatures listed in Table 7-1 for temperature range	Refer to Table 7-1
Storage Humidity	EIA-364-31	Refer to Table 7-1
Electrical Tests		
Current	EIA-364-70 Method 3, 30-degree temperature rise Contacts energized: Up to a maximum of 6 adjacent contacts per side, 12 contacts total	Refer to Table 7-1 for current magnitude

4
5

1 **Appendix A. System Mechanical Specification (Informative)**

2 **A.1. Overview**

3 All material within this section, whether defined as normative or informative, is subject to IP disclosure and RAND
4 terms by SNIA SFF TWG member companies.

5 **A.2. PCB Layout**

6 **A.2.1 Standalone Connector Footprint**

8

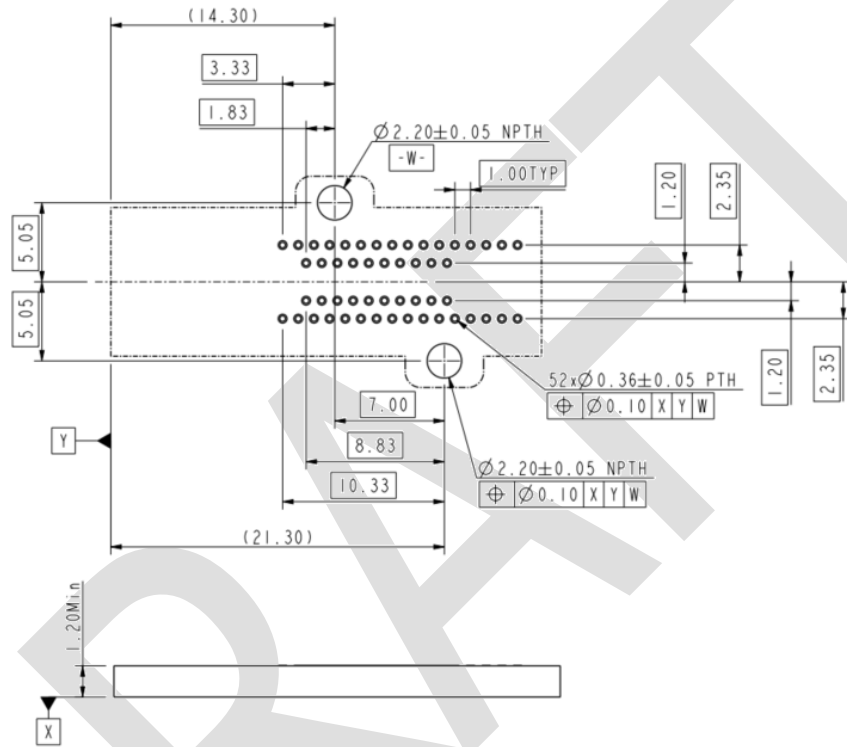

9

10 **Figure A-1 Recommended Standalone Connector Footprint with RS20**

11

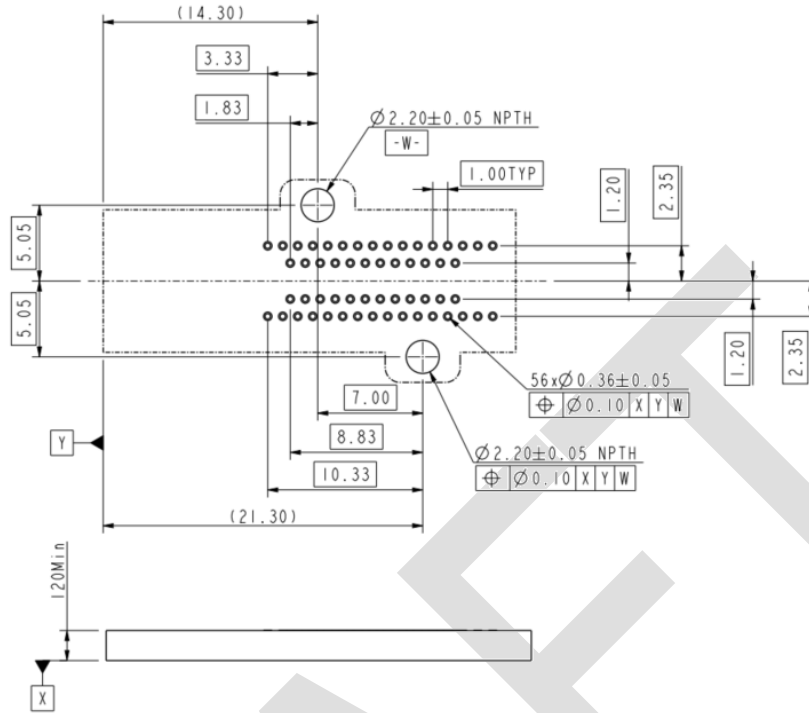

Figure A-2 Recommended Standalone Connector Footprint with RS24

A.2.2 Ganged Connector Footprint

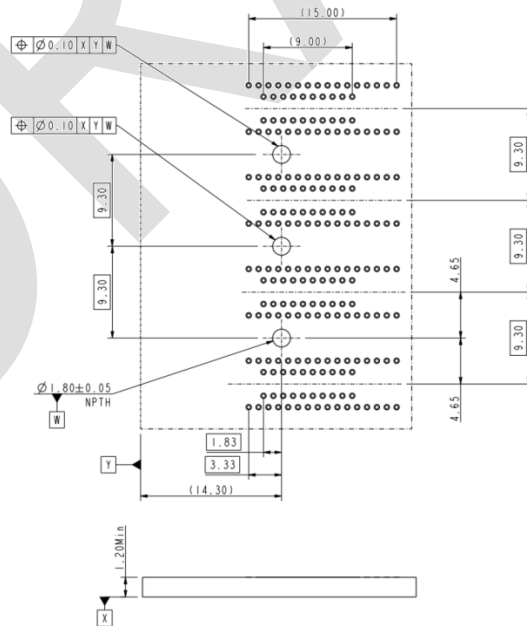

Figure A-3 Recommended Ganged Connector Footprint with RS20

1
2
3
4
5
6
7
8

9
10
11

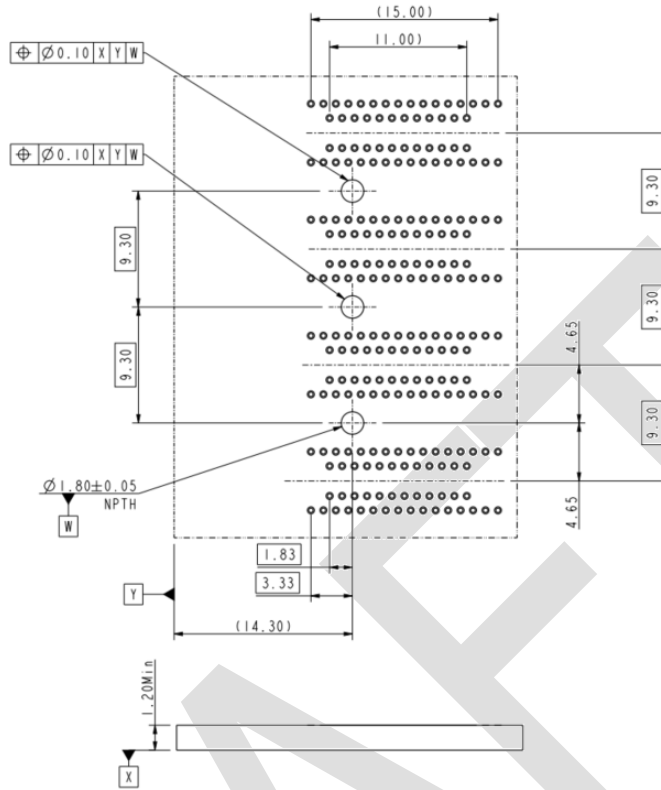

Figure A-4 Recommended Ganged Connector Footprint with RS24

1
2
3
4
5
6
7
8

Appendix B. Labeling Connector Type (Informative)

A human legible label indicating connector type ("Type 2" or "T2") shall be placed anywhere on the viewing side of the connectors shown below. Figure B-1 shows the face of the 1C connector. Figure B-2 shows the face of the 2C connector. Figure B-3 shows the face of the 4C connector.

9
10
11
12
13
14

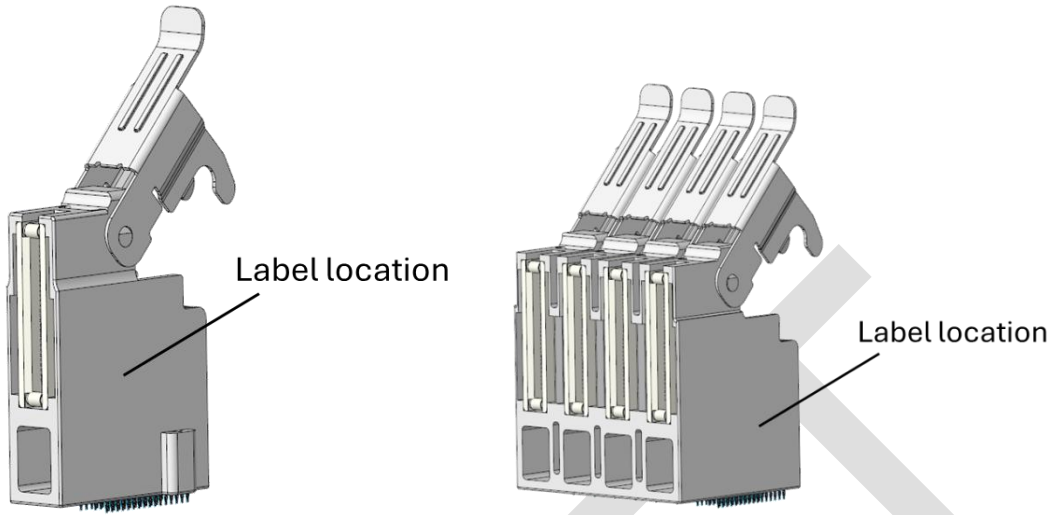

Figure B-1 1C Connector Label Location

1
2
3
4

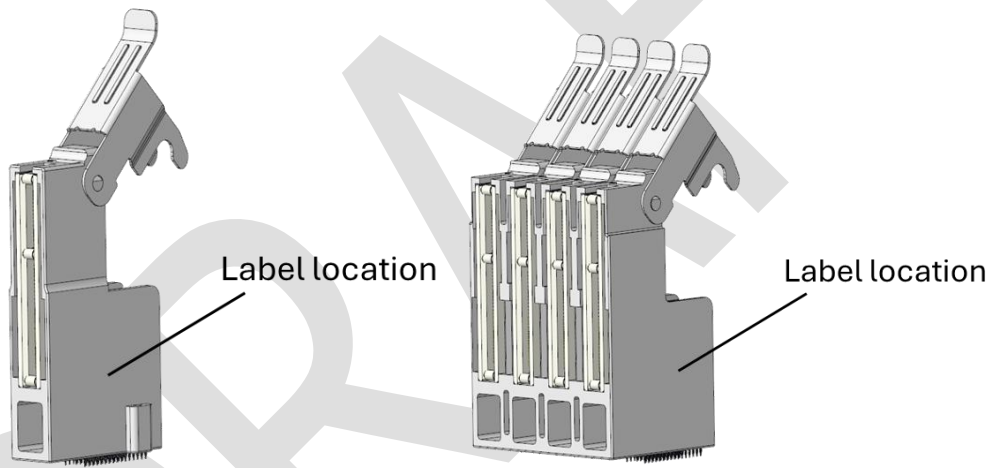

Figure B-2 2C Connector Label Location

5
6
7
8

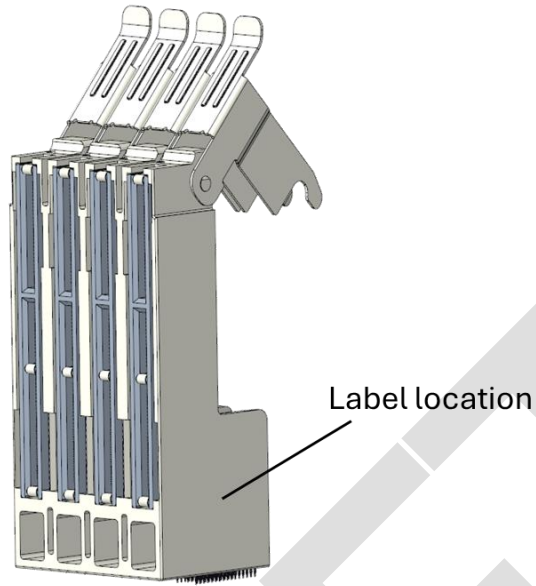

Figure B-3 4C Connector Label Location

1
2
3
4
5
6
7

DRAFT