



## SFF-TA-1031

Specification for

# SFP2 Cage, Connector, & Module Specification

Rev 1.0

June 11, 2023

SECRETARIAT: SFF TA TWG

This specification is made available for public review at <https://www.snia.org/sff/specifications>. Comments may be submitted at <https://www.snia.org/feedback>. Comments received will be considered for inclusion in future revisions of this specification.

The description of the connector in this specification does not assure that the specific component is available from connector suppliers. If such a connector is supplied, it should comply with this specification to achieve interoperability between suppliers.

**ABSTRACT:** This specification defines the electrical and optical connectors, mechanical and thermal requirements of the pluggable SFP2 module which is a compatible evolution of SFP+/SFP28. This document provides a common specification for systems manufacturers, system integrators, and suppliers of modules.

This specification provides a common reference for systems manufacturers, system integrators, and suppliers.

**POINTS OF CONTACT:**

Dan Gorenc  
TE Connectivity  
2901 Fulling Mill Rd  
Middletown, PA 17057  
Email: [dan.gorenc@te.com](mailto:dan.gorenc@te.com)

Chairman SFF TA TWG  
Email: [SFF-Chair@snia.org](mailto:SFF-Chair@snia.org)

**INTELLECTUAL PROPERTY**

The user's attention is called to the possibility that implementation of this specification may require the use of an invention covered by patent rights. By distribution of this specification, no position is taken with respect to the validity of a claim or claims or of any patent rights in connection therewith.

This specification is considered SNIA Architecture and is covered by the SNIA IP Policy and as a result goes through a request for disclosure when it is published. Additional information can be found at the following locations:

- Results of IP Disclosures: <https://www.snia.org/sffdisclosures>
- SNIA IP Policy: <https://www.snia.org/ippolicy>

**COPYRIGHT**

The SNIA hereby grants permission for individuals to use this document for personal use only, and for corporations and other business entities to use this document for internal use only (including internal copying, distribution, and display) provided that:

1. Any text, diagram, chart, table or definition reproduced shall be reproduced in its entirety with no alteration, and,
2. Any document, printed or electronic, in which material from this document (or any portion hereof) is reproduced shall acknowledge the SNIA copyright on that material, and shall credit the SNIA for granting permission for its reuse.

Other than as explicitly provided above, there may be no commercial use of this document, or sale of any part, or this entire document, or distribution of this document to third parties. All rights not explicitly granted are expressly reserved to SNIA.

Permission to use this document for purposes other than those enumerated (Exception) above may be requested by e-mailing [copyright\\_request@snia.org](mailto:copyright_request@snia.org). Please include the identity of the requesting individual and/or company and a brief description of the purpose, nature, and scope of the requested use. Permission for the Exception shall not be unreasonably withheld. It can be assumed permission is granted if the Exception request is not acknowledged within ten (10) business days of SNIA's receipt. Any denial of permission for the Exception shall include an explanation of such refusal.

**DISCLAIMER**

The information contained in this publication is subject to change without notice. The SNIA makes no warranty of any kind with regard to this specification, including, but not limited to, the implied warranties of merchantability and fitness for a particular purpose. The SNIA shall not be liable for errors contained herein or for incidental or consequential damages in connection with the furnishing, performance, or use of this specification.

Suggestions for revisions should be directed to <https://www.snia.org/feedback/>.

**FOREWORD**

The development work on this specification was done by the SFP-DD MSA and given to the SFF TA TWG, a SNIA Technical Affiliate Technical Working Group, for continued development. Since its formation as the SFF Committee in August 1990, the membership has included a mix of companies which are leaders across the industry.

For those who wish to participate in the activities of the SFF TA TWG, the signup for membership can be found at <https://www.snia.org/sff/join>.

**REVISION HISTORY**

Rev 1.0	June 11,2023
	-Initial Publication

**CONTENTS**

1.	Scope	6
2.	References and Conventions	6
2.1	Industry Documents	6
2.2	Sources	6
2.3	Conventions	6
3.	Keywords, Acronyms, and Definitions	8
3.1	Keywords	8
3.2	Acronyms and Abbreviations	8
3.3	Definitions	9
4.	General Description	11
4.1	Configuration Overview/Descriptions	11
4.1.1	Connector Configuration	11
4.2	Contact Numbering	11
5.	Connector Mechanical Specification	12
5.1	Overview	12
5.1.1	Datums	12
5.2	SFP2 Cage, Connector, Module Alignment	13
5.2.1	SFP2 SMT Electrical Connector	15
5.2.2	SFP2 SMT Host PCB Layout	15
6.	Cage Mechanical Specification	18
6.1	Overview	18
6.1.1	Optional Cage Heat Sink Opening	19
7.	Module Mechanical Specification	19
7.1	Overview	19
7.2	Module	20
7.3	Module Flatness and Roughness	22
7.4	SFP2 Improved Module Paddle Card Dimensions	22
7.5	SFP2 Module Extraction and Retention Forces	24
8.	Environmental and Thermal	24
8.1	Thermal Requirements	24
9.	Normative Module and Connector Performance Requirements	24
9.1	Performance Tables	24

**FIGURES**

Figure 3-1 Plug and Receptacle Definition	9
Figure 3-2 Right Angle Connector	10
Figure 3-3 Wipe for a Continuous Contact	10
Figure 4-1 Connector Mating Example	11
Figure 5-1 SFP2 1x1 Cage and Host PCB Layout	14
Figure 5-2 SFP2 SMT Connector	15
Figure 5-3 SFP2 Host Pad Layout	16
Figure 5-4 SFP2 Detailed Host Pad Layout Detail U	17
Figure 5-5 1x1 Connector Design and Host PCB Pad Numbers	18
Figure 6-1 Cage Heat Sink Opening	19
Figure 7-1 SFP2 Module Dimensions	21
Figure 7-2 SFP2 High Speed Pads Viewing Windows	22
Figure 7-3 SFP2 Improved Module Paddle Card Dimensions	23

**TABLES**

Table 2-1 Standards References	6
Table 5-1 Datum Descriptions	12
Table 7-1 Module flatness specifications	22
Table 8-1 Temperature Range Class of Operation	24
Table 9-1 Form Factor Performance Requirements	25
Table 9-2 EIA-364-1000 Test Details	26
Table 9-3 Additional Test Procedures	27

## 1. Scope

This specification defines the SFP2 module, cage and connector system. SFP2 supports 112 Gb/s over single electrical lane. The cage and connector design provides backwards compatibility to SFP+/SFP28. SFP2 cage and connectors are compatible with SFP+/SFP28 modules.

Note: Modules, connectors and cages for 50 Gb/s PAM4 (up to 28 GBd) that are marketed as "SFP56" follow the mechanical and low-speed specifications for SFP28 (see SFF-8402), alternatively they may follow this specification.

## 2. References and Conventions

### 2.1 Industry Documents

The following documents are relevant to this specification:

- SFP-DD/SFP-DD112/SFP112
  - Hardware Specification for SFP112 and SFP Double Density Pluggable Transceiver
- CMIS OIF IA Common Management Interface Specification
- ASME Y14.5-2018 Dimensioning and Tolerancing
- EIA-364-1000 Environmental Test Methodology for Assessing the Performance of Electrical Connectors and Sockets Used in Controlled Environment Applications
- EN61000-4-2 IEC immunity standard on ESD, criterion B test specification
- INF-8074 SFP (Small Formfactor Pluggable) Transceiver, Rev. 1.0
- NEBS GR-63 Physical Protection Requirements for Network Telecommunications Equipment
- REF-TA-1011 Cross Reference to Select SFF Connectors
- SFF-8402 SFP+ 1x 28 Gb/s Pluggable Transceiver Solution (SFP28)
- 
- SFF-8432 SFP+ Module and Cage
- SFF-8433 SFP+ Ganged Cage Footprints and Bezel Openings
- SFF-8472 Diagnostic Monitoring Interface for Optical Transceivers

### 2.2 Sources

The complete list of SFF documents which have been published, are currently being worked on, or that have been expired by the SFF Committee can be found at <https://www.snia.org/sff/specifications>. Suggestions for improvement of this specification will be welcome, they should be submitted to <https://www.snia.org/feedback>.

Other standards may be obtained from the organizations listed below:

**Table 2-1 Standards References**

Standard	Organization	Website
ASME	American Society of Mechanical Engineers (ASME)	<a href="https://www.asme.org">https://www.asme.org</a>
Electronic Industries Alliance (EIA)	Electronic Components Industry Association (ECIA)	<a href="https://www.ecianow.org">https://www.ecianow.org</a>
OIF	Optical Internetworking Forum (OIF)	<a href="http://www.oiforum.com">http://www.oiforum.com</a>

### 2.3 Conventions

The following conventions are used throughout this document:

#### DEFINITIONS

Certain words and terms used in this standard have a specific meaning beyond the normal English meaning. These words and terms are defined either in the definitions or in the text where they first appear.

**ORDER OF PRECEDENCE**

If a conflict arises between text, tables, or figures, the order of precedence to resolve the conflicts is text; then tables; and finally figures. Not all tables or figures are fully described in the text. Tables show data format and values.

**DIMENSIONING CONVENTIONS**

The dimensioning conventions are described in ASME-Y14.5, Geometric Dimensioning and Tolerancing. All dimensions are in millimeters, which are the controlling dimensional units (if inches are supplied, they are for guidance only).

**NUMBERING CONVENTIONS**

The ISO convention of numbering is used (i.e., the thousands and higher multiples are separated by a space and a period is used as the decimal point). This is equivalent to the English/American convention of a comma and a period.

<b>American</b>	<b>French</b>	<b>ISO</b>
0.6	0,6	0.6
1,000	1 000	1 000
1,323,462.9	1 323 462,9	1 323 462.9

### 3. Keywords, Acronyms, and Definitions

For the purposes of this document, the following keywords, acronyms, and definitions apply.

#### 3.1 Keywords

**May:** Indicates flexibility of choice with no implied preference.

**May or may not:** Indicates flexibility of choice with no implied preference.

**Optional:** Describes features which are not required by the SFF specification. However, if any feature defined by the SFF specification is implemented, it shall be done in the same way as defined by the specification. Describing a feature as optional in the text is done to assist the reader.

**Shall:** Indicates a mandatory requirement. Designers are required to implement all such mandatory requirements to ensure interoperability with other products that conform to this specification.

**Should:** Indicates flexibility of choice with a strongly preferred alternative.

#### 3.2 Acronyms and Abbreviations

**AOC:** active optical cable

**EMLB:** early mate late break

**IDC:** insulation displacement contact

**IDT:** insulation displacement termination

**PCB:** printed circuit board

**PF:** press fit

**PTH:** plated through hole

**RA:** right angle

**SMT:** surface mount technology



### 3.3 Definitions

**Alignment guides:** A term used to describe features that pre-align the two halves of a connector interface before electrical contact is established. Other common terms include: guide pins, guideposts, blind mating features, mating features, alignment features, and mating guides.

**Basic (dimension):** The theoretical exact size, profile, orientation, or location of a feature. It is used as the basis from which permissible variations are established by tolerances in notes or in feature control frames (GD&T).

**Connector:** Each half of an interface that, when joined together, establish electrical contact and mechanical retention between two components. In this specification, the term connector does not apply to any specific gender; it is used to describe the receptacle, the plug or the card edge, or the union of receptacle to plug or card edge. Other common terms include: connector interface, mating interface, and separable interface.

**Contact mating sequence:** A term used to describe the order of electrical contact established/ terminated during mating/un-mating. Other terms include: contact sequencing, contact positioning, mate first/break last, EMLB (early mate late break) staggered contacts, and long pin/short pin.

**Contacts:** A term used to describe connector terminals that make electrical connections across a separable interface.

**Datum:** A point, line, plane, etc. assumed to be exact for the purposes of computation or reference, as established from actual features, and from which the location or geometric relationship of a feature is established.

**Module:** In this specification, module may refer to a plug assembly at the end of a copper (electrical) cable (passive or active), an active optical cable assembly, an optical transceiver, or a loopback.

**Plug:** A term used to describe the connector that contains the penetrating contacts of the connector interface as shown in Figure 3-1. Plugs typically contain stationary contacts. Other common terms include male, pin connector, and card edge.

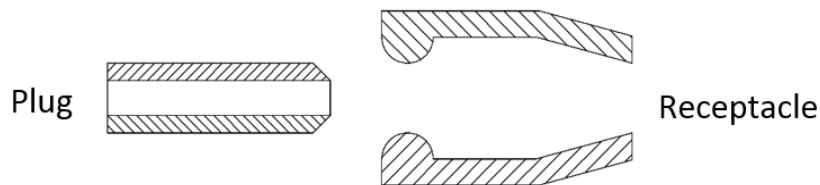

**Figure 3-1 Plug and Receptacle Definition**

**Plated through hole termination:** A term used to describe a termination style in which rigid pins extend into or through the PCB. Pins are soldered to keep the connector or cage in place. Other common terms are through hole or PTH.

**Press fit:** A term used to describe a termination style in which collapsible pins penetrate the surface of a PCB. Upon insertion, the pins collapse to fit inside the PCB's plated through holes. The connector or cage is held in place by the interference fit between the collapsed pins and the PCB.

**Receptacle:** A term used to describe the connector that contains the contacts that accept the plug contacts as shown in Figure 3-1. Receptacles typically contain spring contacts. Other common terms include female and socket connector.

**Reference (dimension):** A dimension provided for information or convenience. It has no tolerance and is not to be used for inspection or conformance. It can be calculated from other tolerance dimensions or can be found elsewhere on the drawing with a tolerance. If removed, it would have no impact on the defined object or the ability

or reproduce it.

**Right Angle:** A term used to describe a connector design where the mating direction is parallel to the plane of the printed circuit board upon which the connector is mounted.

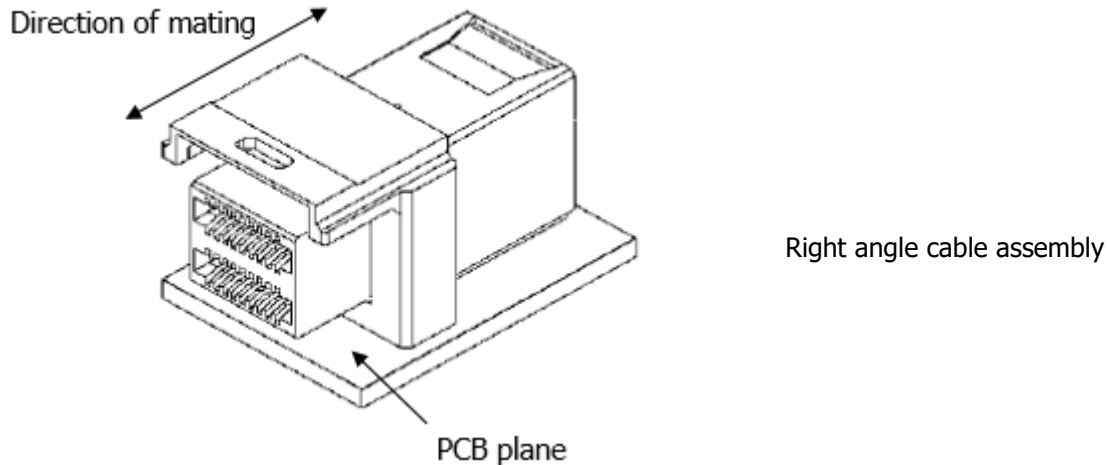

**Figure 3-2 Right Angle Connector**

**Straight:** A term used to describe a connector design where the mating direction is parallel to the bulk cable.

**Surface mount:** A term used to describe a termination style in which solder tails sit on pads on the surface of a PCB and are then soldered to keep the connector or cage in place. Other common terms are surface mount technology or SMT.

**Termination:** A term used to describe a connector's non-separable attachment point such as [a connector contact to a bulk cable/ a cage to a PCB or flex circuit/ bulk cable to a PCB or flex circuit/ solder tail to PCB]. Common PCB terminations include: surface mount (SMT), plated through hole termination (PTH), and press fit (PF). Common cable terminations include insulation displacement contact (IDC), insulation displacement termination (IDT), wire slots, solder, welds, crimps, and brazes.

**Wipe:** The distance a contact travels on the surface of its mating contact during the mating cycle as shown in Figure 3-3.

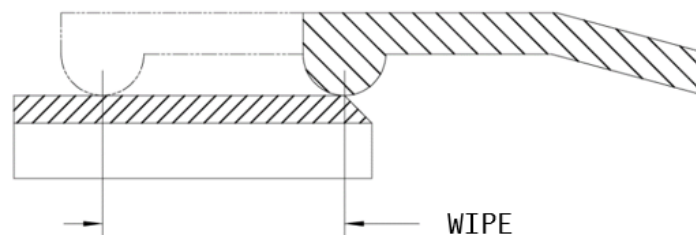

**Figure 3-3 Wipe for a Continuous Contact**

## 4. General Description

### 4.1 Configuration Overview/Descriptions

The SFP2 form factor system consists of a transceiver module, cage and connector optimized for higher speed applications. The cage and connectors are backward compatible with SFP+/SFP28.

In addition to contacts for the high-speed data signals, the connector provides contacts for module and channel control and status signals including a pair that form a Two-Wire Interface (TWI) for communication with the module's memory.

SFP2 modules may use SFF-8472 or CMIS for management. For higher speeds such as 50 Gb/s or 100 Gb/s, the Common Management Interface Specification (CMIS) is recommended.

#### 4.1.1 Connector Configuration

An example SFP2 mating connector pair is shown in Fig 4-1.



**Figure 4-1 Connector Mating Example**

### 4.2 Contact Numbering

The pins or electrical contacts numbering in this connector can be found in the drawings in Section 5, The Connector Mechanical Specification.

## 5. Connector Mechanical Specification

### 5.1 Overview

SFP2 module mechanical specifications are compatible with SFP+/SFP28 module mechanical specifications. Below is the list of relevant SFP+/SFP28 sections applicable to SFP2:

SFF-8432

- IPF General descriptions, Section 3.0
- IPF Modules Dimensions, Retention/Extraction, and Durability, Section 4
- IPF Cage Requirements, Section 5

INF-8074

- SFP Single Cage Host Board Mechanical Layout, Figure 4B

SFF-8433

- SFP+ Ganged Cage Host Board Mechanical Layout, Section 4

The module paddle card dimensions of the SFP2 have been improved to support 100 Gb/s PAM4 (up to 56 GBd) serial data rates compared to SFP+/SFP28.

SFP2 supports multiple connector/cage form factors. All combinations of cages/connectors defined in this specification are backwards compatible to accept classic SFP28 and SFP+ modules. In addition, SFP2 modules are compatible with SFP+/SFP28 hosts for operation at lower speed.

Note: Modules, connectors and cages for 50 Gb/s PAM4 (up to 28 GBd) that are marketed as "SFP56" may follow the mechanical and low-speed specifications for SFP28 (see SFF-8402), alternatively they may follow this specification.

#### 5.1.1 Datums

The datums defined in Table 5-1 are used throughout the rest of the document to describe the dimensional requirements of this connector.

**Table 5-1 Datum Descriptions**

Datum	Description
A	Center line of connector slot
B	Bottom surface of connector
C	Round guidepost of connector
D	Leading edge of signal contact pads on module paddle card
E	Leading edge of low-speed contact pads on module paddle card
F	Front edge of module paddle card
G	Top surface of module paddle card
H	Center line of module paddle card width
K	Host board through hole #1 to accept connector guidepost
L	Host board through hole #2 to accept connector guidepost
M	Vertical center line of Datum L and Datum K
N	Top surface of host board
P	Hard stop on module
R	Hard stop on cage
S	Host board through hole to accept primary cage press fit pin
T	Center line of module width
U	Bottom surface of module

## 5.2 SFP2 Cage, Connector, Module Alignment

The alignment of the cage, connector, and module is shown in Figure 5-1.

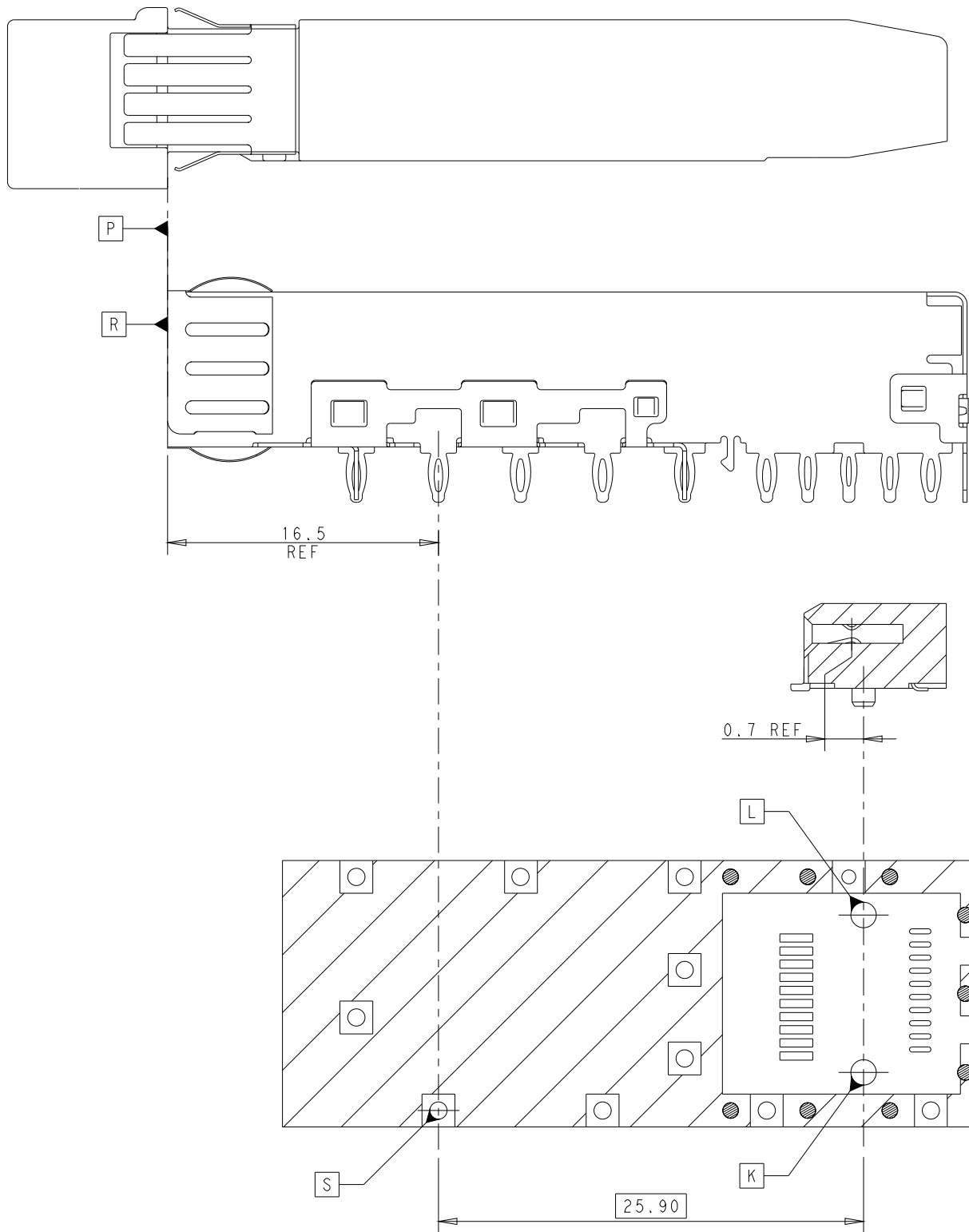

Figure 5-1 SFP2 1x1 Cage and Host PCB Layout

### 5.2.1 SFP2 SMT Electrical Connector

The SFP2 connector is a 20-contact improved right-angle connector compatible with SFP+ modules. The SFP2 SMT connector is shown in Figure 5-2.

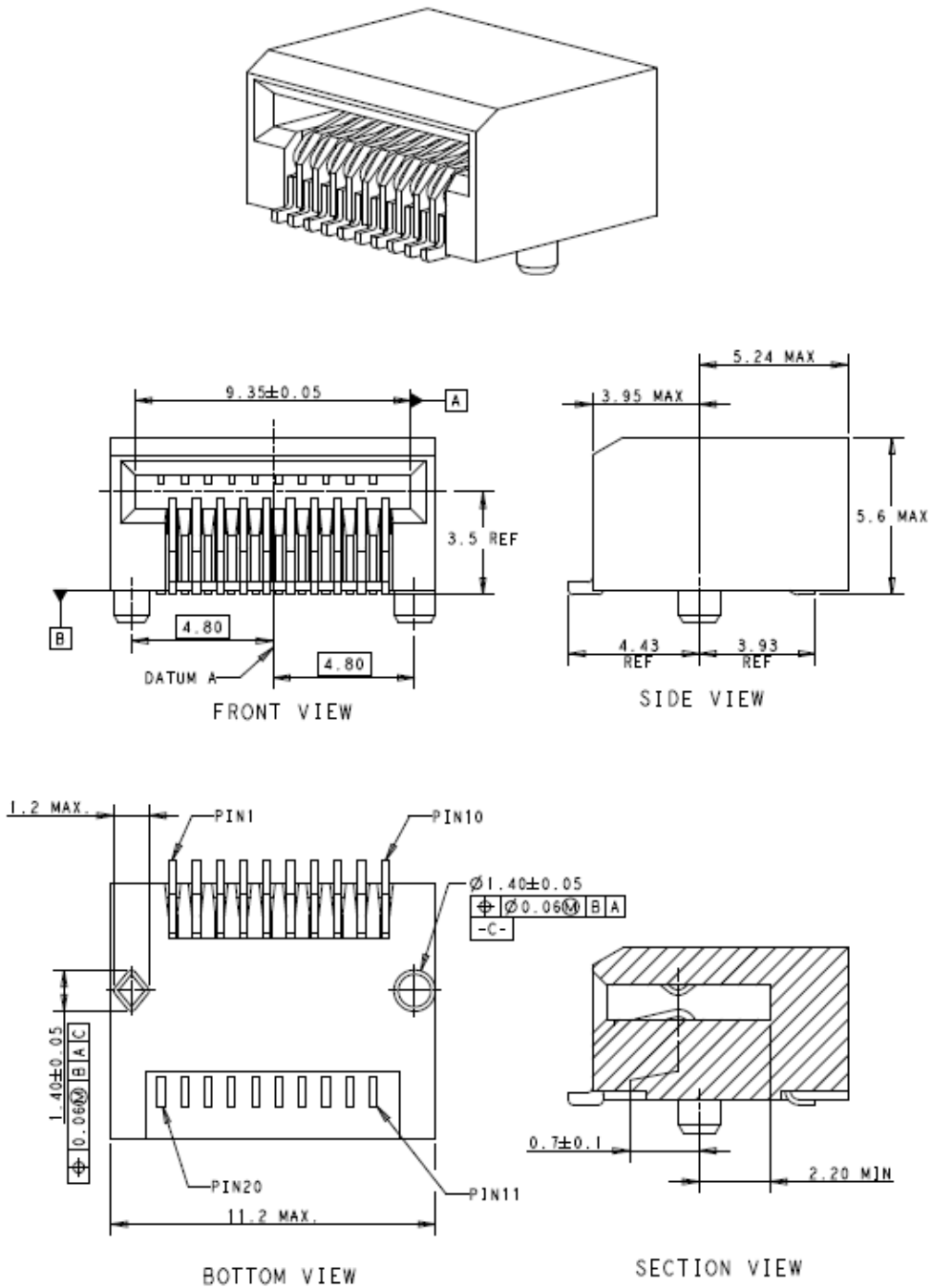

Figure 5-2 SFP2 SMT Connector

### 5.2.2 SFP2 SMT Host PCB Layout

A typical host board mechanical layout for attaching the SFP2 surface mount connector is shown in Figure 5-3 Figure 5-3 SFP2 Host Pad Layout. The optimized SFP2 host pad layout is shown in and the host PCB pad numbers

shown in Figure 5-5. Note: the cage footprint for SFP2 is the same as SFP cage footprint: see INF-8074i, SFP (Small Formfactor Pluggable) Transceiver, Rev. 1.0, Figure 4A.

To achieve 112 Gbps (56 GBd) operation the SFP2 pad dimensions and associated tolerances have improved compared to SFP+/SFP28 as shown in Figure 5-4. One must adhere and pay attention to the host board layout for 56 GBd operation.

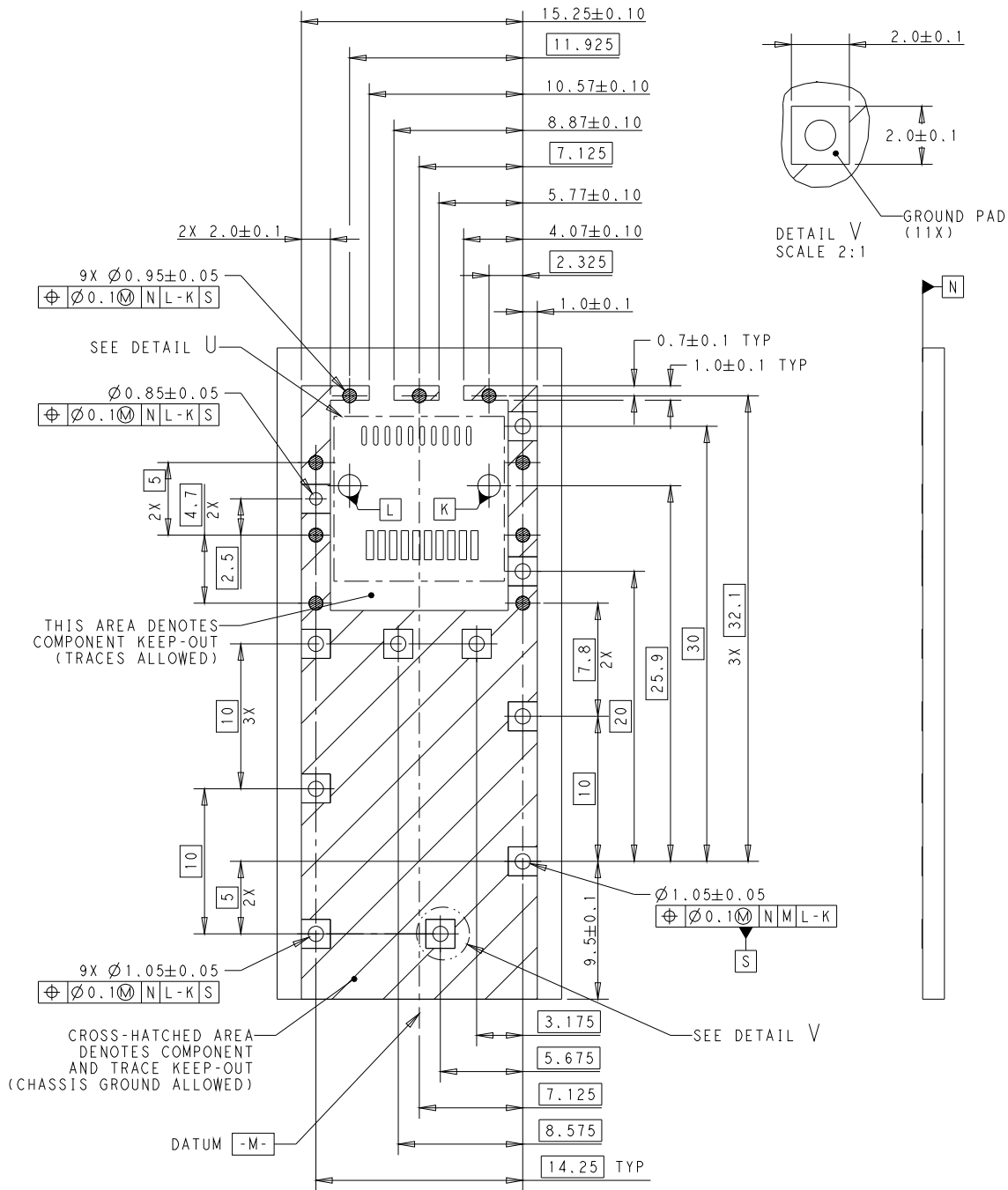

Figure 5-3 SFP2 Host Pad Layout



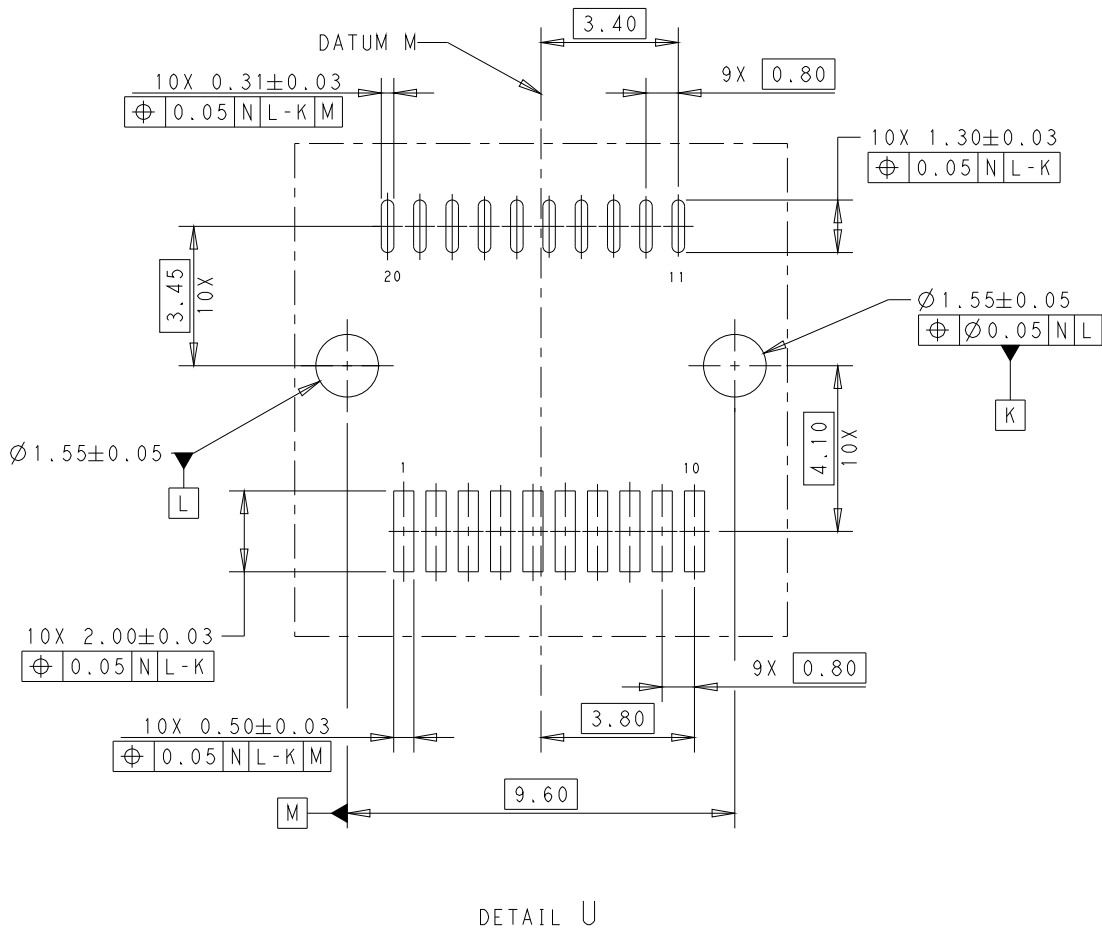
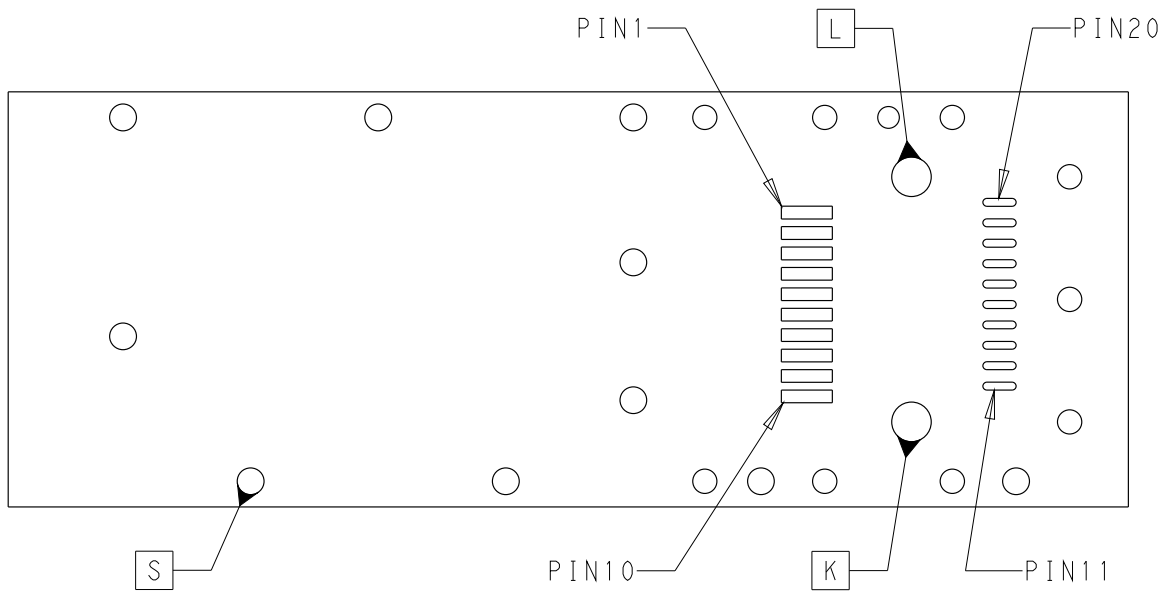

Figure 5-4 SFP2 Detailed Host Pad Layout Detail U



**Figure 5-5 1x1 Connector Design and Host PCB Pad Numbers**

## 6. Cage Mechanical Specification

### 6.1 Overview

The SFP2 Cage is backward compatible with and mechanically identical to the SFP+ and SFP28 cages. The cage dimensions and details are available in those documents. However, in some instances there may be a need for additional thermal management considerations. If there is a need for heat sinks, the cage heat sink openings are defined in the following section.

### 6.1.1 Optional Cage Heat Sink Opening

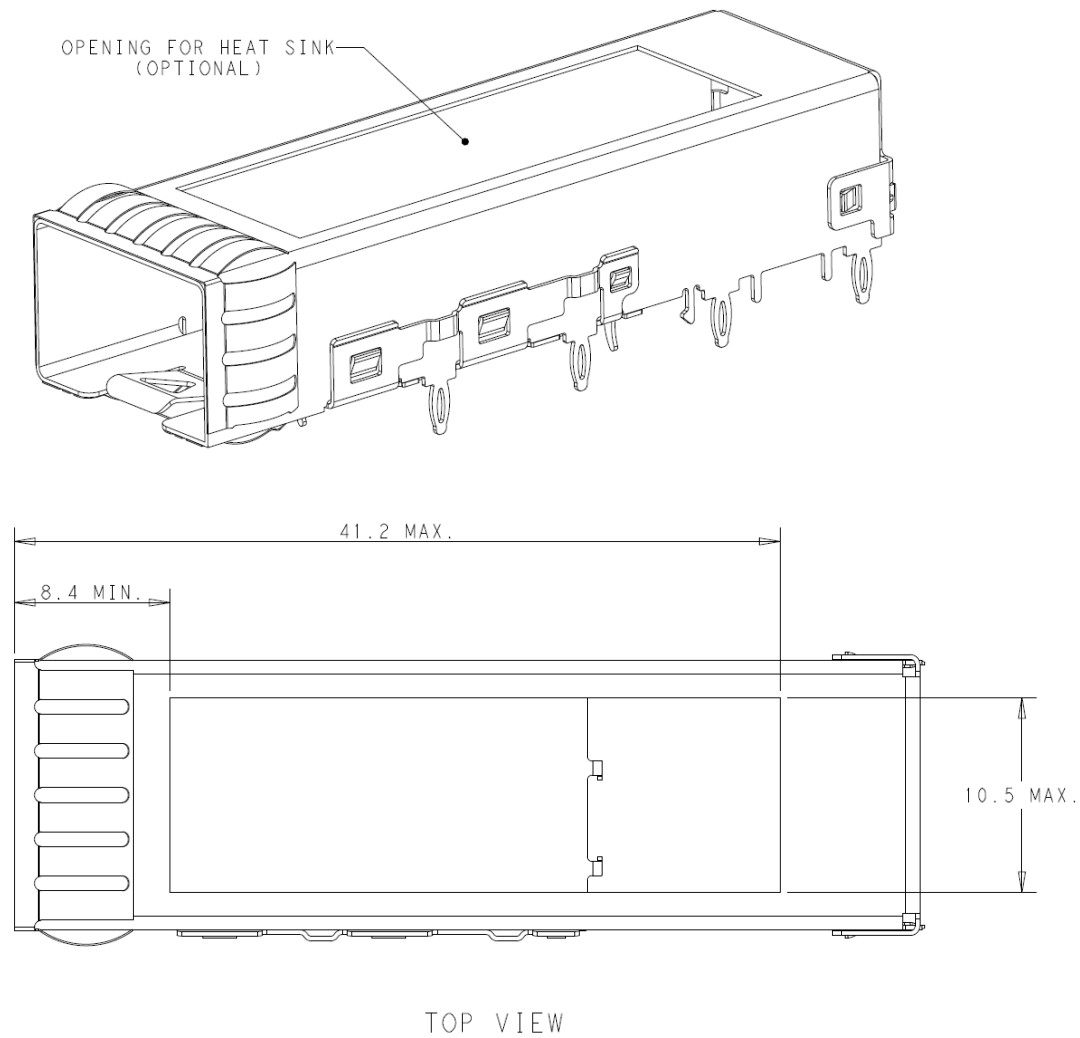

**Figure 6-1 Cage Heat Sink Opening**

## 7. Module Mechanical Specification

### 7.1 Overview

SFP2 modules' mechanical dimensions are identical to SFP+/SFP28 modules with the exception of two viewing windows to inspect the high-speed pads as shown in Figure 7-1. An SFP28/ cage (see SFF-8402) can be used with the SFP2 connector. For SFP2 modules the bottom surface of the module within the cage shall be flat without a pocket with the exception of an optional label pocket as described in Figure 7-1. The options for the position and the bottom view of the label could include the bottom surface of the module that protrudes outside the bezel of the cage or etched into the metal surface. Caution should be exercised that any etchings do not affect thermal performance.

Flatness and roughness specs to both top and bottom surfaces of SFP2 module are defined in Section 7.3.

## 7.2 Module

Notes Apply to Module Drawings (Table 7-1 and Figure 7-2)

1. Dimensioning and tolerancing conform to ASME Y14.5.
2. Break all sharp edges and remove all burrs.
3. Recommended maximum module length extending outside of cage. Other lengths are application specific.
4. The indicated outline defines maximum envelope outside the cage. The surfaces of the maximum envelope may be contacted by adjacent module EMI springs during insertion and extraction of the module from the cage. The surfaces shall not have any shapes or materials that can damage the adjacent module EMI springs or be damaged themselves by the springs.
5. Dimensions define EMI spring contact point with module cage.
6. Flatness specification applies over the entire heat sink area. Refer to Table 7-1 for flatness requirements.
7. Product label on bottom or sides to be flush or recessed below external surfaces. Label shall not interfere with the mechanical, thermal, or EMC properties.

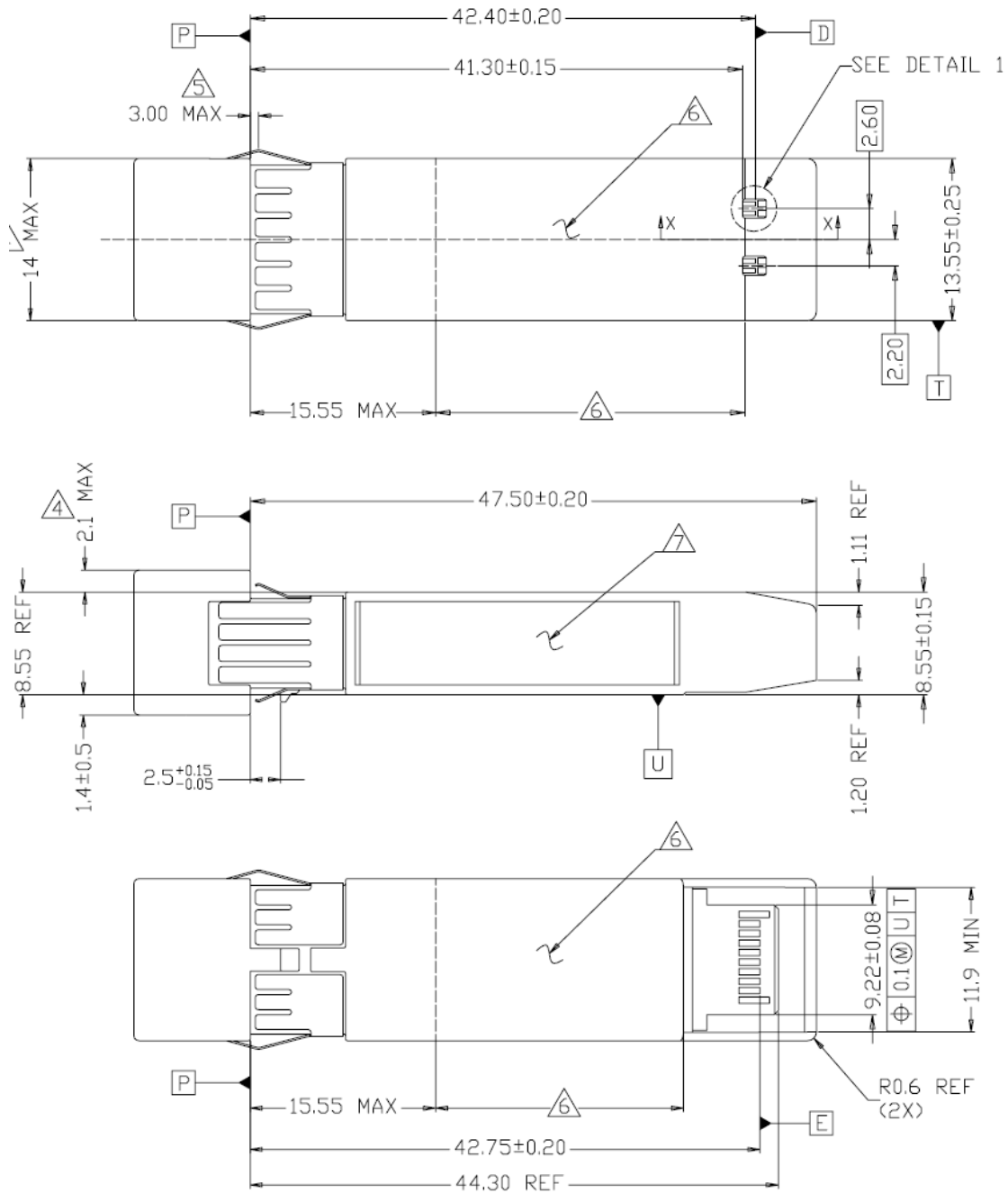

Figure 7-1 SFP2 Module Dimensions

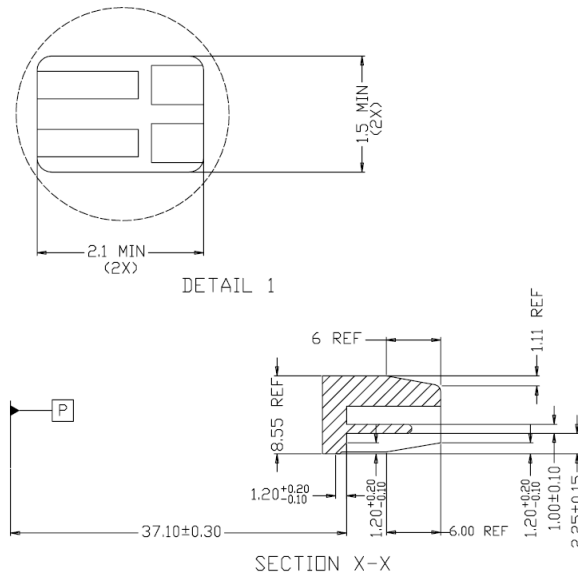

Figure 7-2 SFP2 High Speed Pads Viewing Windows

### 7.3 Module Flatness and Roughness

Module flatness and roughness are specified to improve module thermal characteristics when used with a riding heat sink. Relaxed specifications are used for lower power modules to reduce cost. The module flatness and roughness specifications apply to the specified heat sink contact area as specified in Figure 7-1. Specifications for module flatness and surface roughness are shown in Table 7-1.

Table 7-1 Module flatness specifications

Power Level	Max Power (W)	Module Flatness (mm) <sup>1</sup>	Surface Roughness (Ra,µm) <sup>2</sup>
1	1.0	0.075	1.6
2	1.5	0.075	1.6
3	2.0	0.075	1.6
4	3.5	0.075	1.6
5	5.0	0.050	0.8
6	reserved	reserved	reserved
7	reserved	reserved	reserved
8	>5W	0.050	0.8

Notes:

- For power dissipation less than 0.1 W, flatness requirement is 0.15 mm.
- Ra is the arithmetic average of the absolute values of the profile height deviations from the mean line, recorded within the specified area.

### 7.4 SFP2 Improved Module Paddle Card Dimensions

The SFP2 module paddle card pad dimensions have been modified to support 112 Gb/s (56 GbD) serial data rates which includes the addition of pre-wipe pads. SFP2 module paddle card pad dimensions optimized for 56 GbD operation are shown in Figure 7-3. All other module dimensions, except for the pads are the same as the SFP+/SFP28 specifications.

Notes for Figure 7-3

- ① Contact Pad Plating
  - 0.38 Micrometers Minimum Gold over
  - 1.27 Micrometers Minimum Nickel
- Alternate Contact Pad Plating
  - 0.05 Micrometers Minimum Gold over
  - 0.30 Micrometers Minimum Palladium over
- ② Components keep out area measured from Datum F
- 3 No solder mask within 0.05 mm of all defined contact pad edges
- 4 No solder mask between end contacts and card edge
- ⑤ Dimensions and positions apply for all pre-wipe and power pads
- ⑥ Dimensions and positions apply for all ground and high-speed signal pads

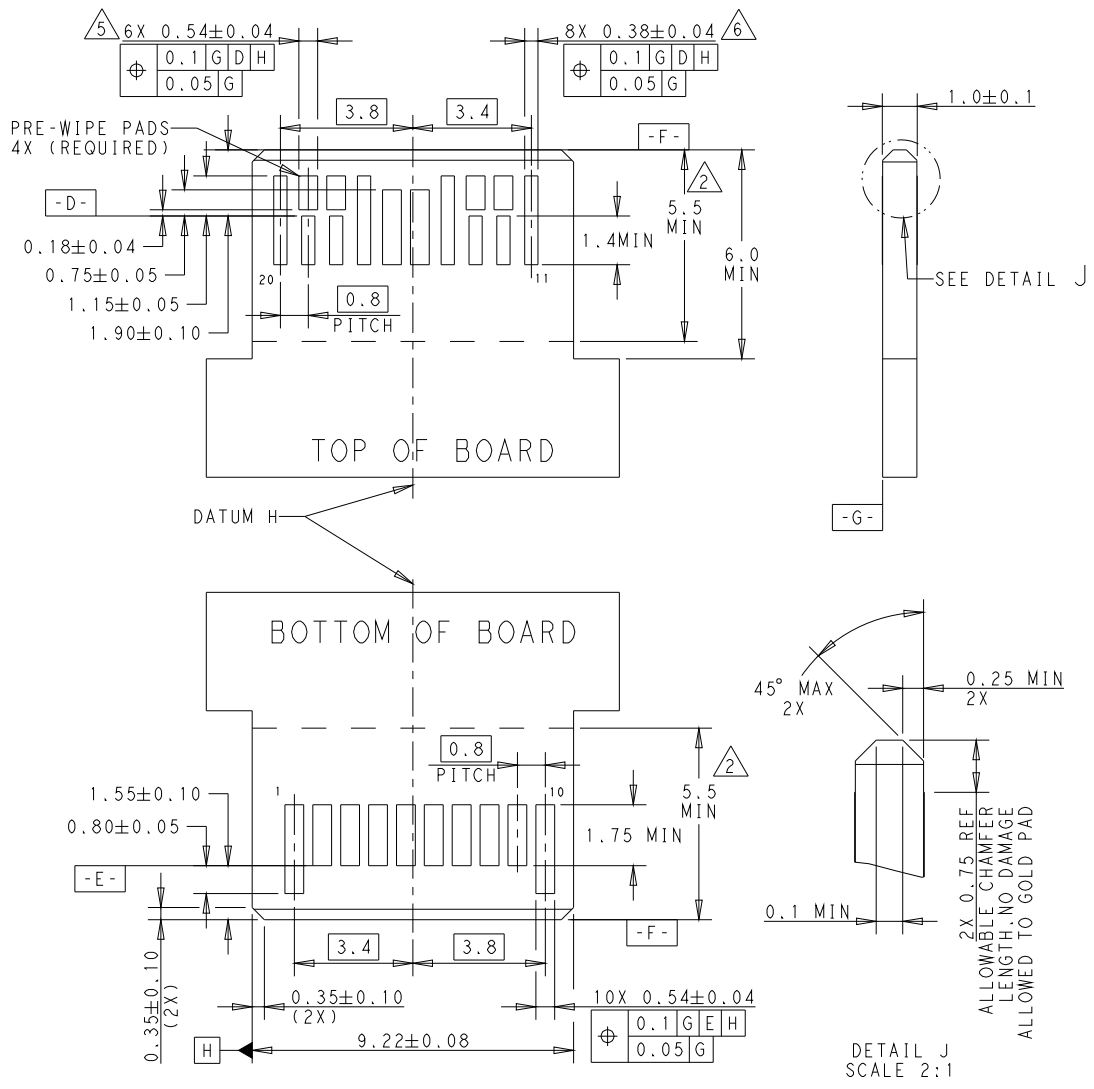

Figure 7-3 SFP2 Improved Module Paddle Card Dimensions

## 7.5 SFP2 Module Extraction and Retention Forces

The requirements for insertion forces, extraction forces and retention forces are specified in Section 9. The SFP2 cage and modules are designed to ensure that excessive force applied to a cable does not damage the SFP2 cage or host connector. If any part is damaged by excessive force, it should be the cable or media module and not the cage or host connector which is part of the host system. Examples of module retention mechanisms are found in SFF-8432 Figures 4-4 through 4-7. The contact pad plating shall meet the requirements in Section 7.4.

## 8. Environmental and Thermal

### 8.1 Thermal Requirements

The SFP2 module shall operate within a defined temperature range such as one of the case temperatures ranges defined in Table 8-1. The temperature ranges are applicable between 60 m below sea level and 1800 m above sea level, NEBS GR-63, utilizing the host system's designed airflow.

**Table 8-1 Temperature Range Class of Operation**

Class	Case Temperature Range
Standard	0°C through 70°C
Extended	-5°C through 85°C
Industrial	-40°C through 85°C

SFP2 is designed to allow for up to 48 modules; stacked, ganged and/or belly-to-belly in a 1U 19" rack, with the appropriate thermal design for cooling/airflow.

## 9. Normative Module and Connector Performance Requirements

### 9.1 Performance Tables

EIA-364-1000 (TS-1000) shall be used to define the test sequences and procedures for evaluating the connector system described in this document. Where multiple test options are available, the manufacturer shall select the appropriate option where not previously specified. The selected procedure should be noted when reporting data. If there are conflicting requirements or test procedures between EIA-364 procedures and those contained within this document, this document shall be considered the prevailing authority.

Unless otherwise specified, procedures for sample size, data, and collection are to be followed as specified in EIA-364-1000. See EIA-364-1000 Annex B for objectives of tests and test groups.



Table 9-1 summarizes the performance criteria that are to be satisfied by the connector described in this document. Most performance criteria are validated by EIA-364-1000 testing, but this test suite leaves some test details to be determined. To ensure that testing is repeatable, these details are identified in Table 9-2. Finally, testing procedures used to validate any performance criteria not included in EIA-364-1000 are provided in Table 9-3.

**Table 9-1 Form Factor Performance Requirements**

Performance Parameters	Description/ Details	Requirements
<b>Mechanical/ Physical Tests</b>		
Plating Type	Plating type on connector contacts	Precious (refer to Section 7.4 for plating details)
Surface Treatment	Surface treatment on connector contacts; if surface treatment is applied, EIA-364-1000 Test Group 6 is required	Manufacturer to specify
Wipe length	Designed distance a contact traverses over a mating contact surface during mating and resting at a final position. If less than 0.127 mm, EIA-364-1000 Test Group 6 is required	Manufacturer to specify
Rated Durability Cycles	The expected number of durability cycles a component is expected to encounter over the course of its life	Connector/ cage: 100 cycles Module: 50 cycles
Mating Force <sup>1</sup>	Amount of force needed to mate a module with a connector when latches are deactivated	SFP2 module: 40 N MAX
Unmating Force <sup>1</sup>	Amount of force needed to separate a module from a connector when latches are deactivated	SFP2 module: 30 N MAX
Latch Retention <sup>1</sup>	Amount of force the latching mechanism can withstand without unmating	SFP2 module: 90 N MIN
Cage Latch Strength <sup>1</sup>	The amount of force that the cage latches can hold without being damaged.	100 N MIN
Cage Retention to Host Board <sup>1</sup>	Amount of force a cage can withstand without separating from the host board	SFP2 module: 100 N MIN
<b>Environmental Requirements</b>		
Field Life	The expected service life for a component	10 years
Field Temperature	The expected service temperature for a component	65°C
<b>Electrical Requirements</b>		
Current	Maximum current to which a contact is exposed in use	0.5 A per signal contact MAX 1.5 A per power contact MAX
Operating Rating Voltage	Maximum voltage to which a contact is exposed in use	30 V DC per contact MAX
<b>Note:</b> 1. These performance criteria are not validated by EIA-364-1000 testing, see Table 9-3 for test procedures and pass/fail criteria.		

Table 9-2 describes the details necessary to perform the tests described in the EIA-364-1000 test sequences. Testing shall be done in accordance with EIA-364-1000 and the test procedures it identifies in such a way that the parameters/ requirements defined in

Table 9-1 are met. Any information in this table supersedes EIA-364-1000. All EIA test procedures can be found in EIA-364-1000.

**Table 9-2 EIA-364-1000 Test Details**

Performance Parameters	Description/ Details	Requirements
<b>Mechanical/ Physical Tests</b>		
Durability (preconditioning)	EIA-364-09 To be tested with connector, cage, and module. Latches may be locked out to aid in automated cycling.	No evidence of physical damage
Durability <sup>1</sup>	EIA-364-09 To be tested with connector, cage, and module. Latches may be locked out to aid in automated cycling.	No visual damage to mating interface or latching mechanism
<b>Environmental Tests</b>		
Cyclic Temperature and Humidity	EIA-364-31 Method IV omitting step 7a Test Duration B	No intermediate test criteria
Vibration	EIA-364-28 Test Condition V Test Condition Letter D Test set-up: Connectors may be restrained by a plate that replicates the system panel opening as defined in this specification. External cables may be constrained to a non-vibrating fixture a minimum of 8 inches from the module.  When cabled connectors are being tested, wires may be attached to the PCB or to a non-vibrating fixture.	No evidence of physical damage -AND- No discontinuities longer than 1 $\mu$ s allowed
<b>Electrical Tests</b>		
Low Level Contact Resistance <sup>2</sup>	EIA-364-23 20 mV DC Max, 100 mA Max To include wire termination or connector-to-board termination	20 m $\Omega$ Max change from baseline
Dielectric Withstanding Voltage	EIA-364-20 Method B 300 V DC minimum for 1 minute Applied voltage may be product / application specific	No defect or breakdown between adjacent contacts -AND- 1 mA max leakage current
Notes:		
<ol style="list-style-type: none"> <li>1. If the durability requirement on the connector is greater than that of the module, modules may be replaced after their specified durability rating.</li> <li>2. The first low level contact resistance reading in each test sequence is used to determine a baseline measurement. Subsequent measurements in each sequence are measured against this baseline.</li> </ol>		

Table 9-3 describes the testing procedures necessary to validate performance criteria not validated by EIA-364-1000 testing. The tests are to be performed in such a way that the parameters/ requirements defined in

Table 9-1 are met.

**Table 9-3 Additional Test Procedures**

Tests	Test Descriptions and Details	Pass/ Fail Criteria
<b>Mechanical/ Physical Tests</b>		
Mating Force <sup>1</sup>	EIA-364-13	Refer to Table 9-1 Form Factor Performance Requirements -AND- No physical damage to any components
Unmating Force <sup>1</sup>	Mating/ unmating rate 12.7 mm/min To be tested with cage, connector, and module. Latching mechanism deactivated (locked out).	
Latch Retention <sup>1</sup>	EIA-364-13 Mating/ unmating rate 12.7 mm/min To be tested with cage, connector, and module. Latching mechanism engaged (not locked out).	
Cage Latch Strength	An axial load applied using a static load or ramped loading to the specified load. To be tested with cage, connector, and module or module representative tool without heat sinks Latching mechanism engaged (not locked out).	
Cage Retention to Host Board	Tested with module, module analog, or fixtures mated to cage. Pull cage in a direction perpendicular to the board at a rate of 25.4 mm/min to the specified force.	
<b>Electrical Tests</b>		
Current	EIA-364-70 Method 3, 30-degree temperature rise Contacts energized: All signal and power contacts energized simultaneously	Refer to Table 9-1 Form Factor Performance Requirements for current magnitude
Note: Values listed in 1. Table 9-1 Form Factor Performance Requirements apply with or without the presence of a riding heat sink.		