



SFF-TA-1016

Specification for

Internal Unshielded High Speed Connector System

Rev 1.3 November 15, 2024.

SECRETARIAT: SFF TA TWG

This specification is made available for public review at <https://www.snia.org/sff/specifications>. Comments may be submitted at <https://www.snia.org/feedback>. Comments received will be considered for inclusion in future revisions of this specification.

The description of the connector in this specification does not assure that the specific component is available from connector suppliers. If such a connector is supplied, it should comply with this specification to achieve interoperability between suppliers.

ABSTRACT: This specification defines the mechanical specifications and general performance requirements for an Internal Unshielded High Speed Connector System that is designed for use in high speed serial interconnect applications. One such use may be as a 4, 8, or 16 lane (or more) receptacle and the mating cable plug for multiple generations of internal high speed applications.

POINTS OF CONTACT:

Paul Coddington
Amphenol High Speed Interconnects
20 Valley Street
Endicott, NY 13760
Ph: 607-754-4444
Email: paul.coddington@amphenol-highspeed.com

Chairman SFF TA TWG
Email: SFF-Chair@snia.org

Zhineng Fan
Amphenol FCI
825 Old Trail Road
Etters, PA 17319
Ph: 717-938-7200
Email: zhineng.fan@amphenol-tcs.com

Intellectual Property

The user's attention is called to the possibility that implementation of this specification may require the use of an invention covered by patent rights. By distribution of this specification, no position is taken with respect to the validity of a claim or claims or of any patent rights in connection therewith.

This specification is considered SNIA Architecture and is covered by the SNIA IP Policy and as a result goes through a request for disclosure when it is published. Additional information can be found at the following locations:

- Results of IP Disclosures: <https://www.snia.org/sffdisclosures>
- SNIA IP Policy: <https://www.snia.org/ippolicy>

Copyright

The SNIA hereby grants permission for individuals to use this document for personal use only, and for corporations and other business entities to use this document for internal use only (including internal copying, distribution, and display) provided that:

1. Any text, diagram, chart, table or definition reproduced shall be reproduced in its entirety with no alteration, and,
2. Any document, printed or electronic, in which material from this document (or any portion hereof) is reproduced shall acknowledge the SNIA copyright on that material, and shall credit the SNIA for granting permission for its reuse.

Other than as explicitly provided above, there may be no commercial use of this document, or sale of any part, or this entire document, or distribution of this document to third parties. All rights not explicitly granted are expressly reserved to SNIA.

Permission to use this document for purposes other than those enumerated (Exception) above may be requested by e-mailing copyright_request@snia.org. Please include the identity of the requesting individual and/or company and a brief description of the purpose, nature, and scope of the requested use. Permission for the Exception shall not be unreasonably withheld. It can be assumed permission is granted if the Exception request is not acknowledged within ten (10) business days of SNIA's receipt. Any denial of permission for the Exception shall include an explanation of such refusal.

Disclaimer

The information contained in this publication is subject to change without notice. The SNIA makes no warranty of any kind with regard to this specification, including, but not limited to, the implied warranties of merchantability and fitness for a particular purpose. The SNIA shall not be liable for errors contained herein or for incidental or consequential damages in connection with the furnishing, performance, or use of this specification.

Suggestions for revisions should be directed to <https://www.snia.org/feedback>.

Foreword

The development work on this specification was done by the SNIA SFF TA TWG, an industry group. Since its formation as the SFF Committee in August 1990, the membership has included a mix of companies that are leaders across the industry.

For those who wish to participate in the activities of the SFF TA TWG, the sign up for membership can be found at <https://www.snia.org/join>.

Revision History

- Rev 1.0** *June 02, 2021:*
- First Publication
- Rev 1.1** *March 01, 2023:*
- Updated the tolerances of dimensions A16, C16, E16, and G16 from ± 0.20 to $+0.20/-0.05$.
 - The values for dimensions B08 and B09 in Table 5-6 were reversed to match the applicable drawing dimensions shown in Figure 5-8.
 - Updated Figure 6-1 and Table 6-1 to add dimension J23.
 - Updated Figure 6-2, Figure 6-3, and Table 6-2 to add dimension L23.
 - Updated Figure 6-4 and Table 6-3 to add dimension N21.
 - Updated Figure 6-5 and Table 6-4 to add dimension Q21.
 - Updated copyright date to 2023.
- Rev 1.2** *March 07, 2024:*
- Minor editorial edits
 - Added the no anti-skew flange versions of the 38P, 124P, and 148P size plugs in the same manner as the 74P size plug that was already included. Added new Figure 6-2 Straight Plug with No Side Flanges for 38 Contacts and modified Table 6-1 accordingly, including adding Notes 1, 2, & 3. Added new Figure 6-6 Straight Plug with No Side Flanges for 124 Contacts and modified Table 6-3 accordingly, including adding Notes 1, 2, & 3. Added new Figure 6-8 Straight Plug with No Side Flanges for 148 Contacts and modified Table 6-4 accordingly, including adding Notes 1, 2, & 3.
 - Updated list of Industry Documents in section 2.1.
 - Added EDSFF to Acronyms and Abbreviations in section 3.2.
 - Added new section 4.1.5 Connector Configuration 5 – Hybrid EDSFF Solution Connectors and inserted a new Figure 4-6, renumbering the remaining section 4 figures accordingly.
 - Inserted a new Section 7 Hybrid EDSFF Solution Mechanical Specification, renumbering the remaining section numbers accordingly. Added new Figure 7-1, new Table 7-1, new Figure 7-2, new Table 7-2, new Figure 7-3, new Table 7-3, new Figure 7-4, new Table 7-4, new Figure 7-5, and new Table 7-5
 - In Appendix A, added new section A.2.5 including new Figure A-5 and new Table A-5.
 - Added a new paragraph to Section 7.1 mentioning how the signals and sidebands may be connected within the hybrid EDSFF solution plugs.
 - Updated Figure 7-1 to align Datum A with the paddle card thickness dimension, K02, since the datum is intended to be the centerline of the paddle card thickness, not the bottom surface.
 - Updated Figure 7-3 to add the missing centerlines in the top view, added dimension BB35, updated dimension BB13, and added the missing True Position tolerance to the BB10 dimension. Also, updated Table 7-3 accordingly.
 - Updated Figure 7-3 to correct a typo regarding dimensions BD19, BD20, and BD21 (were incorrectly labeled in this figure as BE19, BE20, and BE21).
 - Updated Figure 7-5 to add the missing centerlines in the top view, added dimension BA35, updated dimension BA13, and moved the True Position tolerance from the BA14 dimension to the BA10 dimension. Also, updated Table 7-5 accordingly.
 - Fixed several website addresses & associated hyperlinks and made a few editorial changes per the Approval Ballot Comment Resolution.
- Rev 1.3** *November 15, 2024:*
- Add hybrid solution pin numbering in section 4.2
 - Update hybrid solution picture in Figure 4-6

- Hybrid E1 receptacle connector is removed. All hybrid plugs mate to hybrid standard receptacle connector. Drawings are updated in section 7.
- Add additional notes to hybrid standard receptacle connector.

Contents

1.	Scope	9
2.	References and Conventions	9
2.1	Industry Documents	9
2.2	Sources	9
2.3	Conventions	10
3.	Keywords, Acronyms, and Definitions	11
3.1	Keywords	11
3.2	Acronyms and Abbreviations	11
3.3	Definitions	12
4.	General Description	14
4.1	Configuration Overview/Descriptions	14
4.1.1	Connector Configuration 1 – 38 Contact Connectors	14
4.1.2	Connector Configuration 2 – 74 Contact Connectors	15
4.1.3	Connector Configuration 3 – 124 Contact Connectors	15
4.1.4	Connector Configuration 4 – 148 Contact Connectors	15
4.1.5	Connector Configuration 5 – Hybrid EDSFF Solution Connectors	16
4.2	Contact Numbering	17
5.	Connector Mechanical Specification	20
5.1	Overview	20
5.1.1	Datums	20
5.2	Mechanical Description: Right Angle Connectors	23
5.2.1	Right Angle Connector with 38 Contacts	23
5.2.2	Right Angle Connector with 74 Contacts	25
5.2.3	Right Angle Connector with 124 Contacts	27
5.2.4	Right Angle Connector with 148 Contacts	29
5.3	Mechanical Description: Vertical Connectors	31
5.3.1	Vertical Connector with 38 Contacts	31
5.3.2	Vertical Connector with 74 Contacts	33
5.3.3	Vertical Connector with 124 Contacts	35
5.3.4	Vertical Connector with 148 Contacts	37
5.4	Outer Locus of the Right Angle Connector and Vertical Connector Mating Contacts	39
5.5	Outer Locus of the SMT Leads	40
6.	Module Mechanical Specification	43
6.1	Overview	43
6.2	Mechanical Description: Plug Modules	43
6.2.1	Plug Connector with 38 Contacts	43
6.2.2	Plug Connector with 74 Contacts	46
6.2.3	Plug Connector with 124 Contacts	48
6.2.4	Plug Connector with 148 Contacts	50
6.2.5	Right Angle Plug Connector with 38/74/124/148 Contacts	52
6.3	Card Edge Description (Mechanical Interface)	53
6.3.1	Plug Paddle Card with 38 Contacts	53
6.3.2	Plug Paddle Card with 74 Contacts	54
6.3.3	Plug Paddle Card with 124 Contacts	55
6.3.4	Plug Paddle Card with 148 Contacts	56
7.	Hybrid EDSFF Solution Mechanical Specification	57
7.1	Hybrid EDSFF Solution Overview	57
7.2	Mechanical Description: EDSFF E1 Hybrid Plugs	57
7.2.1	Hybrid Plug with 38 Contacts and E1 1C Connector	57
7.2.2	Hybrid Plug with 38 Contacts and E1 2C Connector	59
7.3	Mechanical Description: EDSFF E3 Hybrid Plugs	61

7.3.1	Hybrid Plug with 38 Contacts and E3 1C Connector	61
7.3.2	Hybrid Plug with 38 Contacts and E3 2C Connector	63
7.4	Hybrid Standard Vertical Receptacle Connector with 38 Contacts	65
8.	Test Requirements and Methodologies (TS-1000, etc.)	67
8.1	Performance Tables	67
9.	Electrical Characteristics	71
9.1	Signal Integrity Requirements	71
Appendix A:	System Mechanical Specification (Informative)	72
A.1	Overview	72
A.2	PCB Layout	72
A.2.1	Recommended PCB layout for Right Angle 38P/74P Connector Footprints	72
A.2.2	Recommended PCB layout for Right Angle 124P/148P Connector Footprints	74
A.2.3	Recommended PCB layout for Vertical 38P/74P Connector Footprints	75
A.2.4	Recommended PCB layout for Vertical 124P/148P Connector Footprints	76
A.2.5	Recommended PCB layout for Hybrid Standard Vertical 38P Connector Footprints	77
Appendix B:	SMT Connector Solder Lead Geometry (Informative)	78
Appendix C:	Reference Pinout Diagrams (Informative)	79
C.1	Overview of Contact Geometry Patterns	79
C.2	Recommended Cable Assembly Wire Diagrams	85
Appendix D:	Gatherability (Informative)	89

Figures

Figure 3-1 Plug and Receptacle Definition	12
Figure 3-2 Right Angle Connector and Cable Assembly	13
Figure 3-3 Wipe for a Continuous Contact	13
Figure 4-1 Family of Right Angle & Straight Plug Connectors and Vertical & Right Angle Receptacle Connectors	14
Figure 4-2 Sample 38 Contact Plug and Receptacle	14
Figure 4-3 Sample 74 Contact Plug and Receptacle	15
Figure 4-4 Sample 124 Contact Plug and Receptacle	15
Figure 4-5 Sample 148 Contact Plug and Receptacle	15
Figure 4-6 Sample Hybrid EDSFF Solution Plugs and Receptacles	16
Figure 4-7 Plug Contact Numbering	17
Figure 4-8 Receptacle Contact Numbering	18
Figure 4-9 Hybrid Plug Contact Numbering on SFF-TA-1002 Interface Side	19
Figure 4-10 Hybrid Plug Contact Numbering on System Board Side	19
Figure 5-1 Right Angle Receptacle Datum Definitions	20
Figure 5-2 Vertical Receptacle Datum Definitions	21
Figure 5-3 Plug Datum Definitions	22
Figure 5-4 Right Angle Connector for 38 Contacts	23
Figure 5-5 Right Angle Connector for 74 Contacts	25
Figure 5-6 Right Angle Connector for 124 Contacts	27
Figure 5-7 Right Angle Connector for 148 Contacts	29
Figure 5-8 Vertical Connector for 38 Contacts	31
Figure 5-9 Vertical Connector for 74 Contacts	33
Figure 5-10 Vertical Connector for 124 Contacts	35
Figure 5-11 Vertical Connector for 148 Contacts	37
Figure 5-12 Outer Locus of 38P Connector Mating Contact Pins	39
Figure 5-13 Outer Locus of 74P Connector Mating Contact Pins	39
Figure 5-14 Outer Locus of 124P Connector Mating Contact Pins	39
Figure 5-15 Outer Locus of 148P Connector Mating Contact Pins	40
Figure 5-16 Outer Locus of 38P Right Angle Connector SMT Leads	40
Figure 5-17 Outer Locus of 74P Right Angle Connector SMT Leads	40
Figure 5-18 Outer Locus of 124P Right Angle Connector SMT Leads	41
Figure 5-19 Outer Locus of 148P Right Angle Connector SMT Leads	41
Figure 5-20 Outer Locus of 38P Vertical Connector SMT Leads	41
Figure 5-21 Outer Locus of 74P Vertical Connector SMT Leads	42
Figure 5-22 Outer Locus of 124P Vertical Connector SMT Leads	42
Figure 5-23 Outer Locus of 148P Vertical Connector SMT Leads	42
Figure 6-1 Straight Plug with Side Anti-skew Flanges for 38 Contacts	43
Figure 6-2 Straight Plug with No Side Flanges for 38 Contacts	44
Figure 6-3 Straight Plug with Side Anti-skew Flanges for 74 Contacts	46
Figure 6-4 Straight Plug with No Side Flanges for 74 Contacts	46
Figure 6-5 Straight Plug with Side Anti-skew Flanges for 124 Contacts	48
Figure 6-6 Straight Plug with No Side Flanges for 124 Contacts	48
Figure 6-7 Straight Plug with Side Anti-skew Flanges for 148 Contacts	50
Figure 6-8 Straight Plug with No Side Flanges for 148 Contacts	50
Figure 6-9 Right Angle Plug for 38/74/124/148 Contacts	52
Figure 6-10 Plug Paddle Card for 38 Contacts	53
Figure 6-11 Plug Paddle Card for 74 Contacts	54
Figure 6-12 Plug Paddle Card for 124 Contacts	55
Figure 6-13 Plug Paddle Card for 148 Contacts	56
Figure 7-1 Hybrid Plug with 38 Contacts and E1 1C Connector	57
Figure 7-2 Hybrid Plug with 38 Contacts and E1 2C Connector	59
Figure 7-3 Hybrid Plug with 38 Contacts and E3 1C Connector	61
Figure 7-4 Hybrid Plug with 38 Contacts and E3 2C Connector	63
Figure 7-5 Hybrid Standard Vertical Receptacle Connector with 38 Contacts	65
Figure A-1 Recommended Footprints for RA 38P/74P	72

Figure A-2 Recommended Footprints for RA 124P/148P	74
Figure A-3 Recommended Footprints for VT 38P/74P	75
Figure A-4 Recommended Footprints for VT 124P/148P	76
Figure A-5 Recommended Footprint for Hybrid Standard Vertical 38P Connectors	77
Figure B-1 SMT Lead Geometry	78
Figure C-1 Sample Wiring Diagram for Cable Assemblies with 38 Contacts	85
Figure C-2 Sample Wiring Diagram for Cable Assemblies with 74 Contacts	86
Figure C-3 Sample Wiring Diagram for Cable Assemblies with 124 Contacts	87
Figure C-4 Sample Wiring Diagram for Cable Assemblies with 148 Contacts	88
Figure D-1 Linear Gatherability	89
Figure D-2 Angular Gatherability	89

Tables

Table 5-1 Datum Descriptions	22
Table 5-2 Dimensions for 38 Contact Right Angle Connectors	24
Table 5-3 Dimensions for 74 Contact Right Angle Connectors	26
Table 5-4 Dimensions for 124 Contact Right Angle Connectors	28
Table 5-5 Dimensions for 148 Contact Right Angle Connectors	30
Table 5-6 Dimensions for 38 Contact Vertical Connectors	32
Table 5-7 Dimensions for 74 Contact Vertical Connectors	34
Table 5-8 Dimensions for 124 Contact Vertical Connectors	36
Table 5-9 Dimensions for 148 Contact Vertical Connectors	38
Table 6-1 Dimensions for 38 Contact Plug Connectors	45
Table 6-2 Dimensions for 74 Contact Plug Connectors	47
Table 6-3 Dimensions for 124 Contact Plug Connectors	49
Table 6-4 Dimensions for 148 Contact Plug Connectors	51
Table 6-5 Paddle Card Dimensions for Plug with 38 Contacts	53
Table 6-6 Paddle Card Dimensions for Plug with 74 Contacts	54
Table 6-7 Paddle Card Dimensions for Plug with 124 Contacts	55
Table 6-8 Paddle Card Dimensions for Plug with 148 Contacts	56
Table 7-1 Dimensions for Hybrid Plug with 38 Contacts and E1 1C Connector	58
Table 7-2 Dimensions for Hybrid Plug with 38 Contacts and E1 2C Connector	60
Table 7-3 Dimensions for Hybrid Plug with 38 Contacts and E3 1C Connector	62
Table 7-4 Dimensions for Hybrid Plug with 38 Contacts and E3 2C Connector	64
Table 7-5 Dimensions for Hybrid Standard Vertical Receptacle Connector with 38 Contacts	66
Table 8-1 Form Factor Performance Requirements	67
Table 8-2 EIA-364-1000 Test Details	69
Table 8-3 Additional Test Procedures	70
Table 9-1 Mated Connector Signal Integrity Requirements	71
Table A-1 Recommended Footprint Dimensions for RA 38P/74P	73
Table A-2 Recommended Footprint Dimensions for RA 124P/148P	74
Table A-3 Recommended Footprint Dimensions for VT 38P/74P	75
Table A-4 Recommended Footprint Dimensions for VT 124P/148P	76
Table A-5 Recommended Footprint Dimensions for Hybrid Standard Vertical 38P Connectors	77
Table B-1 SMT Lead Geometry Dimensions	78
Table C-1 Connector Contact Types By Location - With No Sidebands	79
Table C-2 Connector Contact Types By Location - With Sidebands	81
Table C-3 Connector Contact Types By Location - With Sidebands for 124P	83

1. Scope

This specification defines the general description of this form factor, the connector and mating plug mechanical specification, some performance requirements, and the electrical interface. Additional informative details such as the PCB layouts are included in an appendix.

2. References and Conventions

2.1 Industry Documents

The following documents are relevant to this specification:

- ASME Y14.5 Dimensioning and Tolerancing
- EIA-364-1000 Environmental Test Methodology for Assessing the Performance of Electrical Connectors and Sockets Used in Controlled Environment Applications
- EIA-364-04 Normal Force Test Procedure for Electrical Connectors
- EIA-364-13 Mating and Unmating Forces Test Procedure for Electrical Connectors
- EIA-364-20 Withstanding Voltage Test Procedure for Electrical Connectors
- EIA-364-21 Insulation Resistance Test Procedure for Electrical Connectors
- EIA-364-23 Low Level Contact Resistance Test Procedure for Electrical Connectors
- EIA-364-27 Mechanical Shock Test Procedure for Electrical Connectors
- EIA-364-28 Vibration Test Procedure for Electrical Connectors and Sockets
- EIA-364-98 Housing Locking Mechanism Strength Test Procedure for Electrical Connectors
- IPC-A-610 Acceptability of Electronic Assemblies
- REF-TA-1012 Pin Assignment Reference for SFF-TA-1002 Connectors
- SFF-8654 0.6mm 4/8X Unshielded I/O Connector
- SFF-9402 Reference Guide for Multi-Protocol Internal Cable Pinouts for SAS and/or PCIe
- SFF-TA-1002 Protocol Agnostic Multi-Lane High Speed Connector
- SFF-TA-1009 Enterprise and Datacenter Standard Form Factor Pin and Signal Specification (EDSFF)
- SFF-TA-1024 Test Specification for SFF-TA-1016 Connector Systems

2.2 Sources

The complete list of SFF documents which have been published, are currently being worked on, or that have been expired by the SFF Committee can be found at <https://www.snia.org/sff/specifications>. Suggestions for improvement of this specification are welcome and should be submitted to <https://www.snia.org/feedback>.

Copies of PCIe standards may be obtained from PCI-SIG (<https://pcisig.com>).

Copies of IEEE standards may be obtained from the Institute of Electrical and Electronics Engineers (IEEE) (<https://www.ieee.org>).

Copies of SAS and other ANSI standards may be obtained from the International Committee for Information Technology Standards (INCITS) (<https://www.incits.org>).

Copies of ASME standards may be obtained from the American Society of Mechanical Engineers (<https://www.asme.org>).

Copies of Electronic Industries Alliance (EIA) standards may be obtained from the Electronic Components Industry Association (ECIA) (<https://www.ecianow.org>).

2.3 Conventions

The following conventions are used throughout this document:

DEFINITIONS

Certain words and terms used in this standard have a specific meaning beyond the normal English meaning. These words and terms are defined either in the definitions or in the text where they first appear.

ORDER OF PRECEDENCE

If a conflict arises between text, tables, or figures, the order of precedence to resolve the conflicts is text; then tables; and finally figures. Not all tables or figures are fully described in the text. Tables show data format and values.

LISTS

Lists sequenced by lowercase or uppercase letters show no ordering relationship between the listed items.

EXAMPLE 1 - The following list shows no relationship between the named items:

- a. red (i.e., one of the following colors):
 - A. crimson; or
 - B. pink;
- b. blue; or
- c. green.

Lists sequenced by numbers show an ordering relationship between the listed items.

EXAMPLE 2 -The following list shows an ordered relationship between the named items:

- 1. top;
- 2. middle; and
- 3. bottom.

Lists are associated with an introductory paragraph or phrase, and are numbered relative to that paragraph or phrase (i.e., all lists begin with an a. or 1. entry).

DIMENSIONING CONVENTIONS

The dimensioning conventions are described in ASME Y14.5, Geometric Dimensioning and Tolerancing. All dimensions are in millimeters, which are the controlling dimensional units (if inches are supplied, they are for guidance only).

NUMBERING CONVENTIONS

The ISO convention of numbering is used (i.e., the thousands and higher multiples are separated by a space and a period is used as the decimal point). This is equivalent to the English/American convention of a comma and a period.

American	French	ISO
0.6	0,6	0.6
1,000	1 000	1 000
1,323,462.9	1 323 462,9	1 323 462.9

3. Keywords, Acronyms, and Definitions

For the purposes of this document, the following keywords, acronyms, and definitions apply.

3.1 Keywords

May or may not: Indicates flexibility of choice with no implied preference.

Obsolete: Indicates that an item was defined in prior specifications but has been removed from this specification.

Optional: Describes features that are not required by the SFF specification. However, if any feature defined by the SFF specification is implemented, it shall be done in the same way as defined by the specification. Describing a feature as optional in the text is done to assist the reader.

Prohibited: Describes a feature, function, or coded value that is defined in a referenced specification to which this SFF specification makes a reference, where the use of said feature, function, or coded value is not allowed for implementations of this specification.

Reserved: Defines the signal on a connector contact [when] its actual function is set aside for future standardization. It is not available for vendor specific use. Where this term is used for bits, bytes, fields, and code values; the bits, bytes, fields, and code values are set aside for future standardization. The default value shall be zero. The originator is required to define a Reserved field or bit as zero, but the receiver should not check Reserved fields or bits for zero.

Restricted: Refers to features, bits, bytes, words, and fields that are set aside for other standardization purposes (e.g., entities). If the context of the specification applies the restricted designation, then the restricted bit, byte, word, or field shall be treated as a value whose definition is not in scope of this document and is not interpreted by this specification.

Shall: Indicates a mandatory requirement. Designers are required to implement all such mandatory requirements to ensure interoperability with other products that conform to this specification.

Should: Indicates flexibility of choice with a strongly preferred alternative.

Vendor specific: Indicates something (e.g., a bit, field, code value) that is not defined by this specification. Specification of the referenced item is determined by the manufacturer and may be used differently in various implementations.

3.2 Acronyms and Abbreviations

AOC: Active Optical Cable

GND: Ground

EDSFF: Enterprise and Datacenter Standard Form Factor

EMLB: Early Mate Late Break

IDC: Insulation Displacement Contact

IDT: Insulation Displacement Termination

PCB: Printed Circuit Board

PF: Press Fit

PTH: Plated Through Hole

RA: Right Angle

SI: Signal Integrity

SMT: Surface Mount Technology

VT: Vertical

3.3 Definitions

Alignment guides: A term used to describe features that pre-align the two halves of a connector interface before electrical contact is established. Other common terms include: guide pins, guide posts, blind mating features, mating features, alignment features, and mating guides.

Connector: Each half of an interface that, when joined together, establish electrical contact and mechanical retention between two components. In this specification, the term connector does not apply to any specific gender; it is used to describe the receptacle, the plug or the card edge, or the union of receptacle to plug or card edge. Other common terms include: connector interface, mating interface, and separable interface.

Contact mating sequence: A term used to describe the order of electrical contact established/ terminated during mating/un-mating. Other terms include: contact sequencing, contact positioning, mate first/break last, EMLB (early mate late break) staggered contacts, and long pin/short pin.

Contacts: A term used to describe connector terminals that make electrical connections across a separable interface.

Module: In this specification, module may refer to a plug assembly at the end of a copper (electrical) cable (passive or active), an active optical cable (AOC), an optical transceiver, or a loopback.

Plug: A term used to describe the connector that contains the penetrating contacts of the connector interface as shown in Figure 3-1. Plugs typically contain stationary contacts. Other common terms include male, pin connector, and card edge.

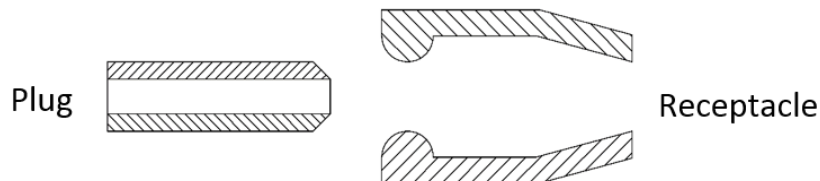

Figure 3-1 Plug and Receptacle Definition

Plated through hole termination: A term used to describe a termination style in which rigid pins extend into or through the PCB. Pins are soldered to keep the connector or cage in place. Other common terms are through hole or PTH.

Press fit: A term used to describe a termination style in which collapsible pins penetrate the surface of a PCB. Upon insertion, the pins collapse to fit inside the PCB's plated through holes. The connector or cage is held in place by the interference fit between the collapsed pins and the PCB.

Receptacle: A term used to describe the connector that contains the contacts that accept the plug contacts as shown in Figure 3-1. Receptacles typically contain spring contacts. Other common terms include female and socket connector.

Right Angle: A term used to describe either a connector design where the mating direction is parallel to the plane of the printed circuit board upon which the connector is mounted or a cable assembly design where the mating direction is perpendicular to the bulk cable.

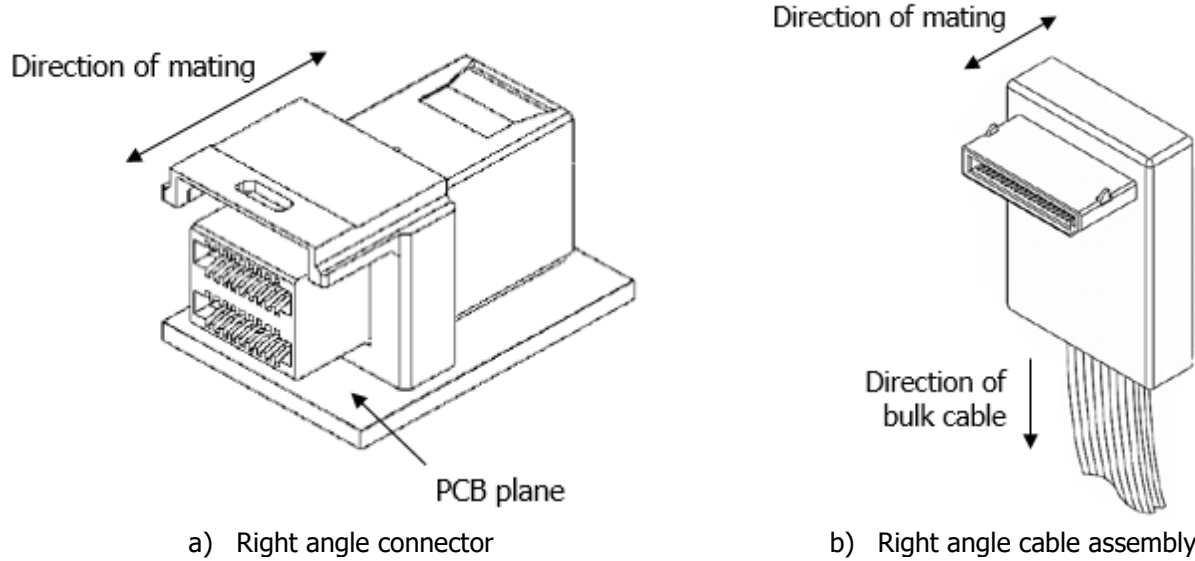

Figure 3-2 Right Angle Connector and Cable Assembly

Straight: A term used to describe a connector design where the mating direction is parallel to the bulk cable.

Surface mount: A term used to describe a termination style in which solder tails sit on pads on the surface of a PCB and are then soldered to keep the connector or cage in place. Other common terms are surface mount technology or SMT.

Termination: A term used to describe a connector’s non-separable attachment point such as a connector contact to a bulk cable or a connector solder tail to a PCB. Common PCB terminations include: surface mount (SMT), plated through hole termination (PTH), and press fit (PF). Common cable terminations include insulation displacement contact (IDC), insulation displacement termination (IDT), wire slots, solder, welds, crimps, and brazes.

Vertical: A term used to describe a connector design where the mating direction is perpendicular to the printed circuit board upon which the connector is mounted.

Wipe: The distance a contact travels on the surface of its mating contact during the mating cycle as shown in Figure 3-3.

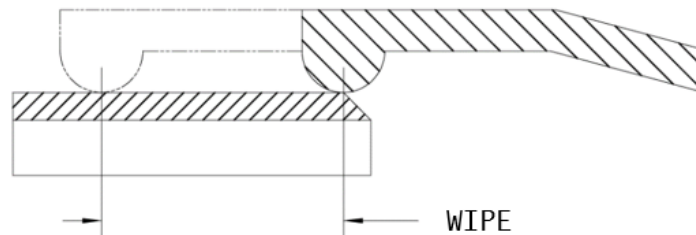

Figure 3-3 Wipe for a Continuous Contact

4. General Description

4.1 Configuration Overview/Descriptions

This specification details a connector system that includes several sizes of straight and right angle plug connectors and the mating right angle and vertical receptacle connectors with 38, 74, 124, or 148 contact positions. The plugs include integrated guidance features for improved stability when mated.

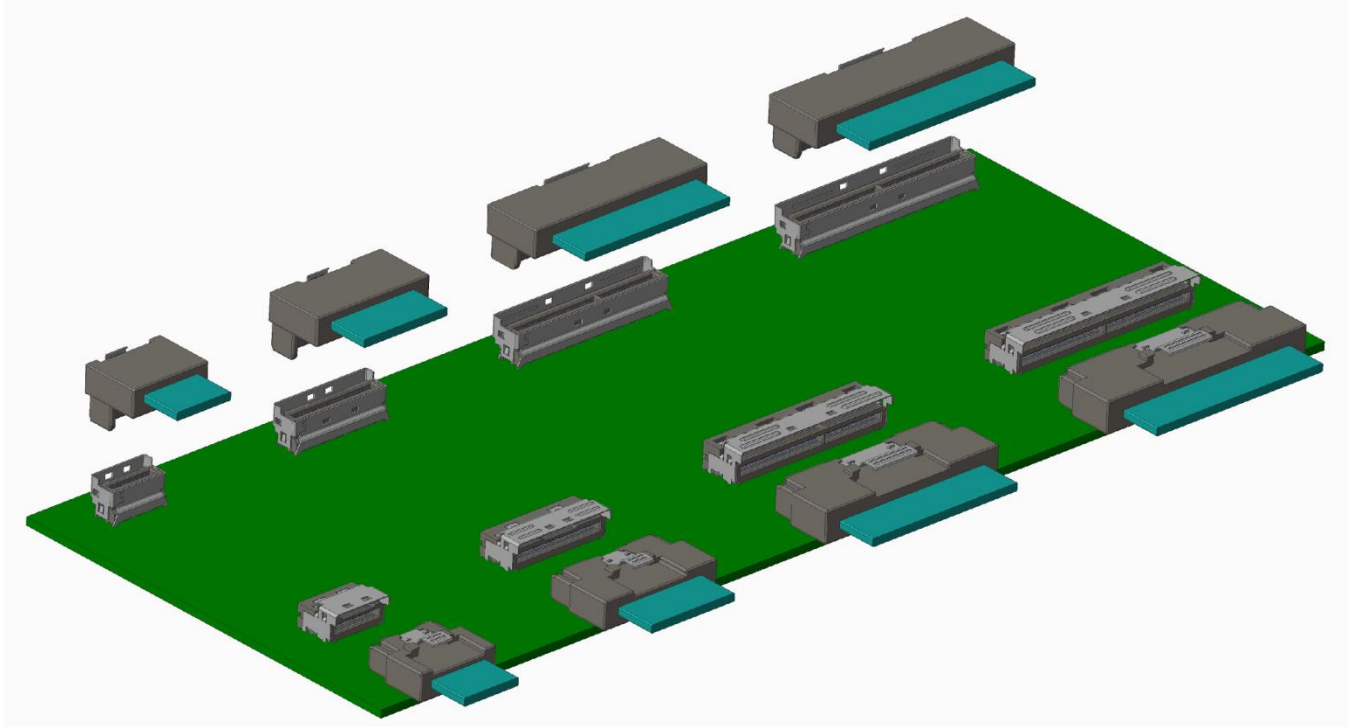

Figure 4-1 Family of Right Angle & Straight Plug Connectors and Vertical & Right Angle Receptacle Connectors

4.1.1 Connector Configuration 1 – 38 Contact Connectors

This configuration is typically used for x4 high speed lane applications with typical sidebands. Alternatively, this configuration can be used for x6 high speed lane applications without sidebands.

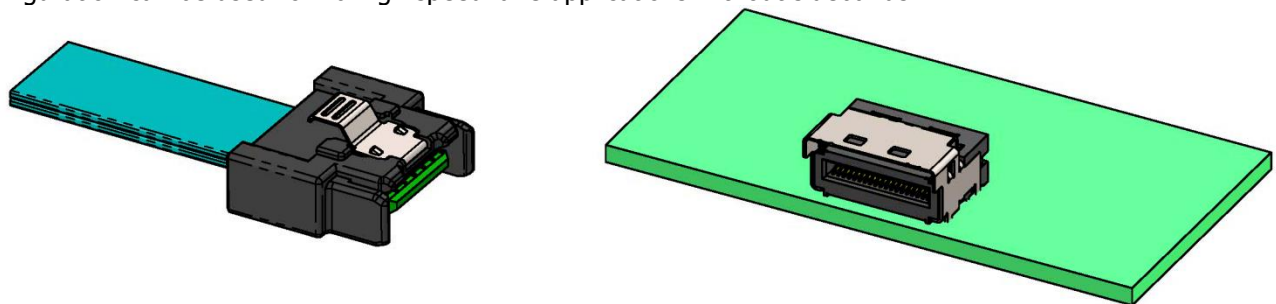

Figure 4-2 Sample 38 Contact Plug and Receptacle

4.1.2 Connector Configuration 2 – 74 Contact Connectors

This configuration is typically used for x8 high speed lane applications with typical sidebands. Alternatively, this configuration can be used for x12 high speed lane applications without sidebands.

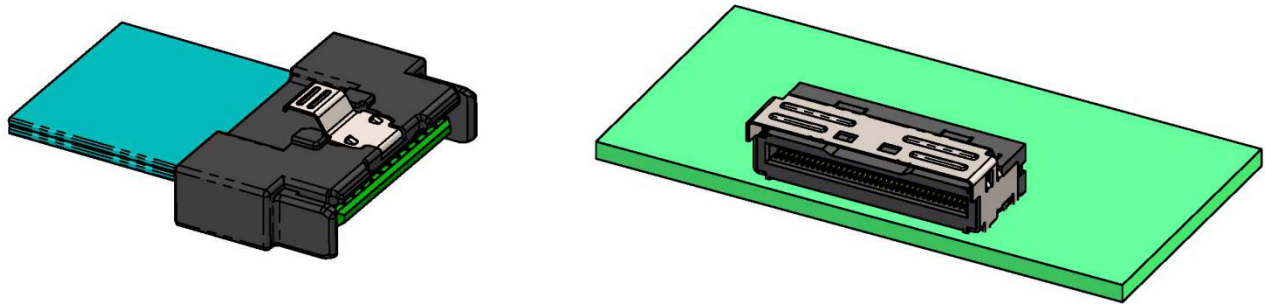

Figure 4-3 Sample 74 Contact Plug and Receptacle

4.1.3 Connector Configuration 3 – 124 Contact Connectors

This configuration is typically used for x16 high speed lane applications with some sidebands. Alternatively, this configuration can be used for x20 high speed lane applications without sidebands.

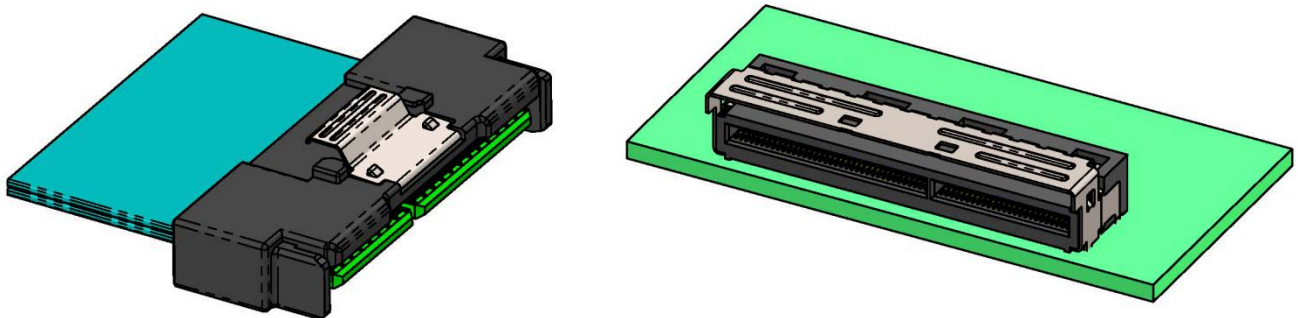

Figure 4-4 Sample 124 Contact Plug and Receptacle

4.1.4 Connector Configuration 4 – 148 Contact Connectors

This configuration is typically used for x16 high speed lane applications with typical sidebands. Alternatively, this configuration can be used for x24 high speed lane applications without sidebands.

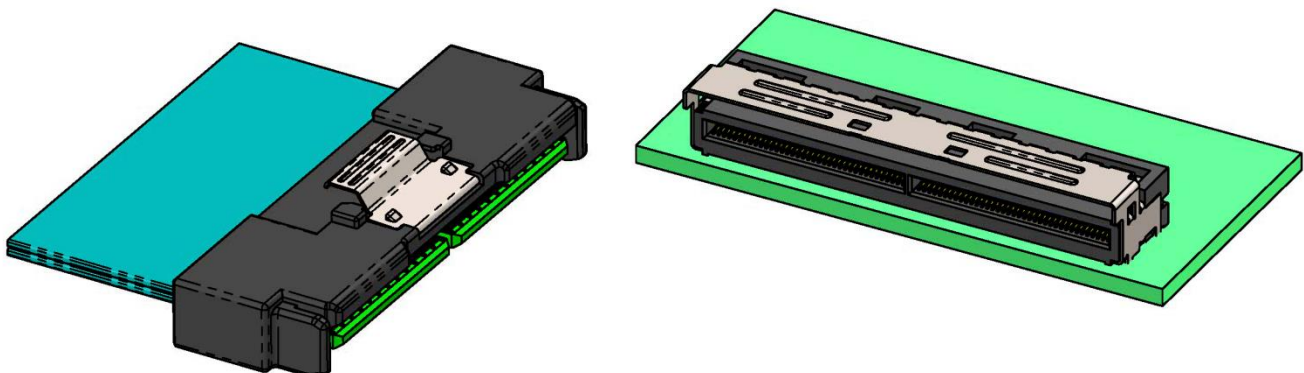

Figure 4-5 Sample 148 Contact Plug and Receptacle

4.1.5 Connector Configuration 5 – Hybrid EDSFF Solution Connectors

This configuration is a compact hybrid plug configuration, where the plug has a mating interface with 38 contacts similar to the other 38 contact plug connectors except it also includes a side exit of the plug that incorporates an SFF-TA-1002 style EDSFF receptacle connector and may or may not include another side exit for cable wires. The mating receptacle connectors in this configuration are vertical type connectors with a larger latch shroud to accommodate the latching mechanism of the hybrid plugs. See section 7 for the various mechanical details of these hybrid plugs and mating receptacles. See SFF-TA-1002 for specifics regarding the 1C side exit interface or 2C side exit interface of the EDSFF style receptacle connector incorporated into these hybrid plug connectors.

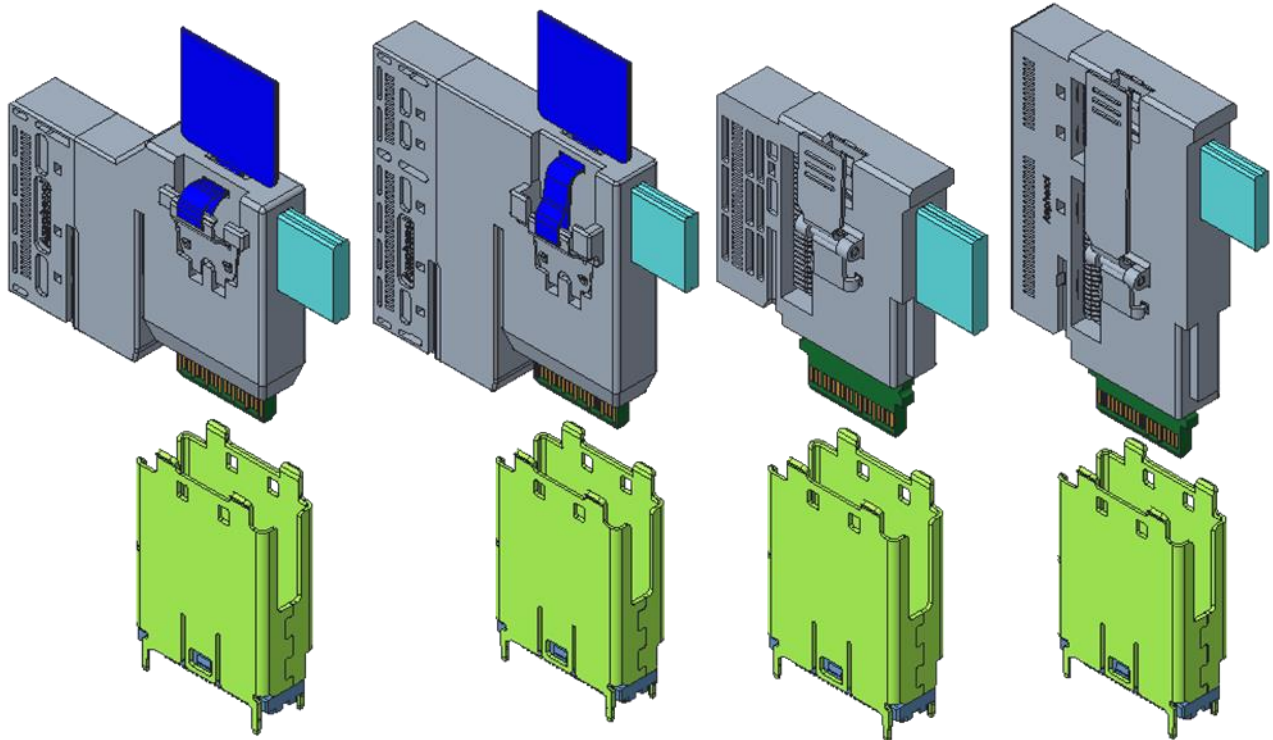
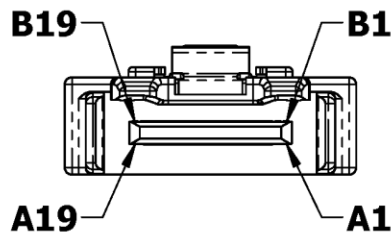

Figure 4-6 Sample Hybrid EDSFF Solution Plugs and Receptacles

4.2 Contact Numbering

The pins or electrical contacts in this connector are numbered as shown in Figure 4-7, Figure 4-8, Figure 4-9 and Figure 4-10.



38 CONTACT PLUGS

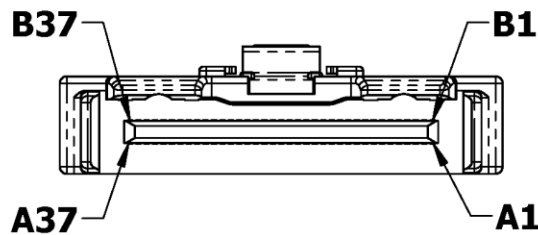

74 CONTACT PLUGS

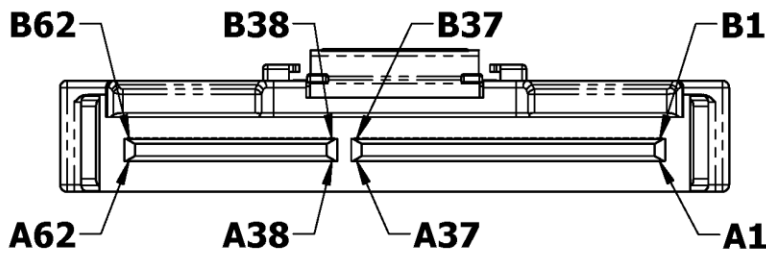

124 CONTACT PLUGS

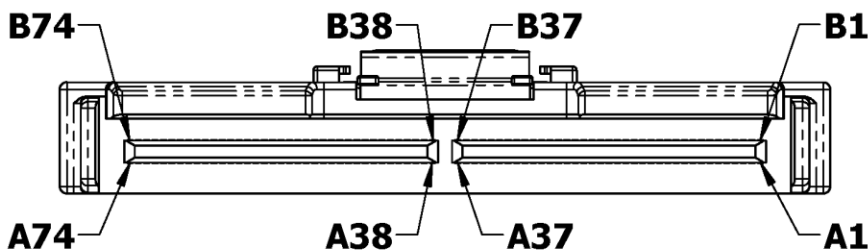

148 CONTACT PLUGS

Figure 4-7 Plug Contact Numbering

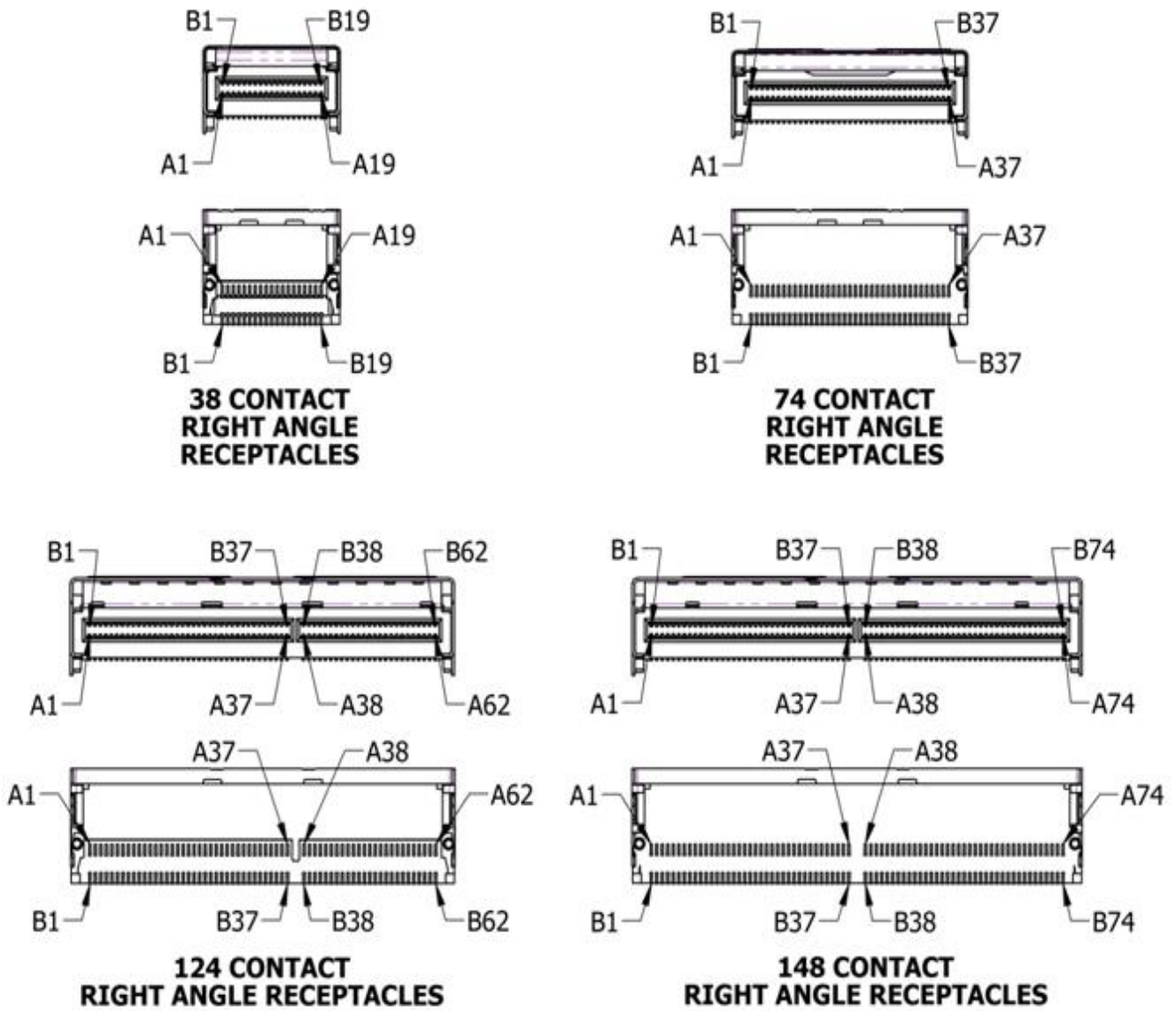
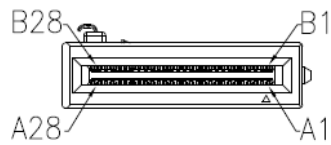
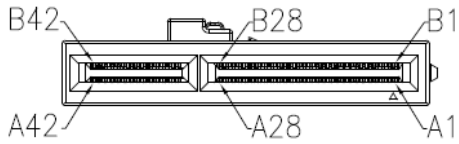

Figure 4-8 Receptacle Contact Numbering



E1 1C Plug



E1 2C Plug

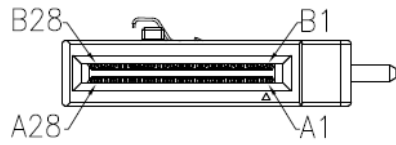

E3 1C Plug

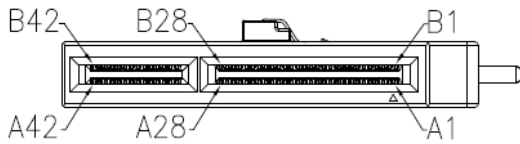

E3 2C Plug

Figure 4-9 Hybrid Plug Contact Numbering on SFF-TA-1002 Interface Side

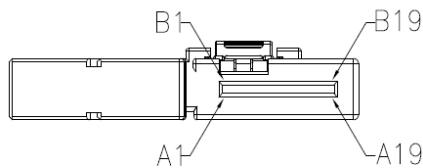

E1 1C Plug

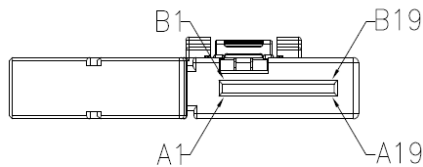

E1 2C Plug

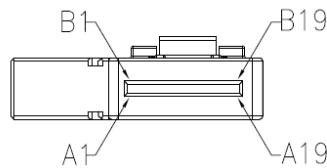

E3 1C Plug

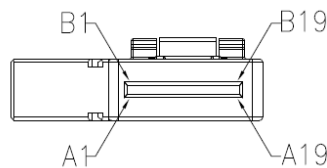

E3 2C Plug

Figure 4-10 Hybrid Plug Contact Numbering on System Board Side

5. Connector Mechanical Specification

5.1 Overview

5.1.1 Datums

The datums defined in Figure 5-1, Figure 5-2, and Figure 5-3, and in Table 5-1 are used throughout the rest of the document to describe the dimensional requirements of this connector.

1

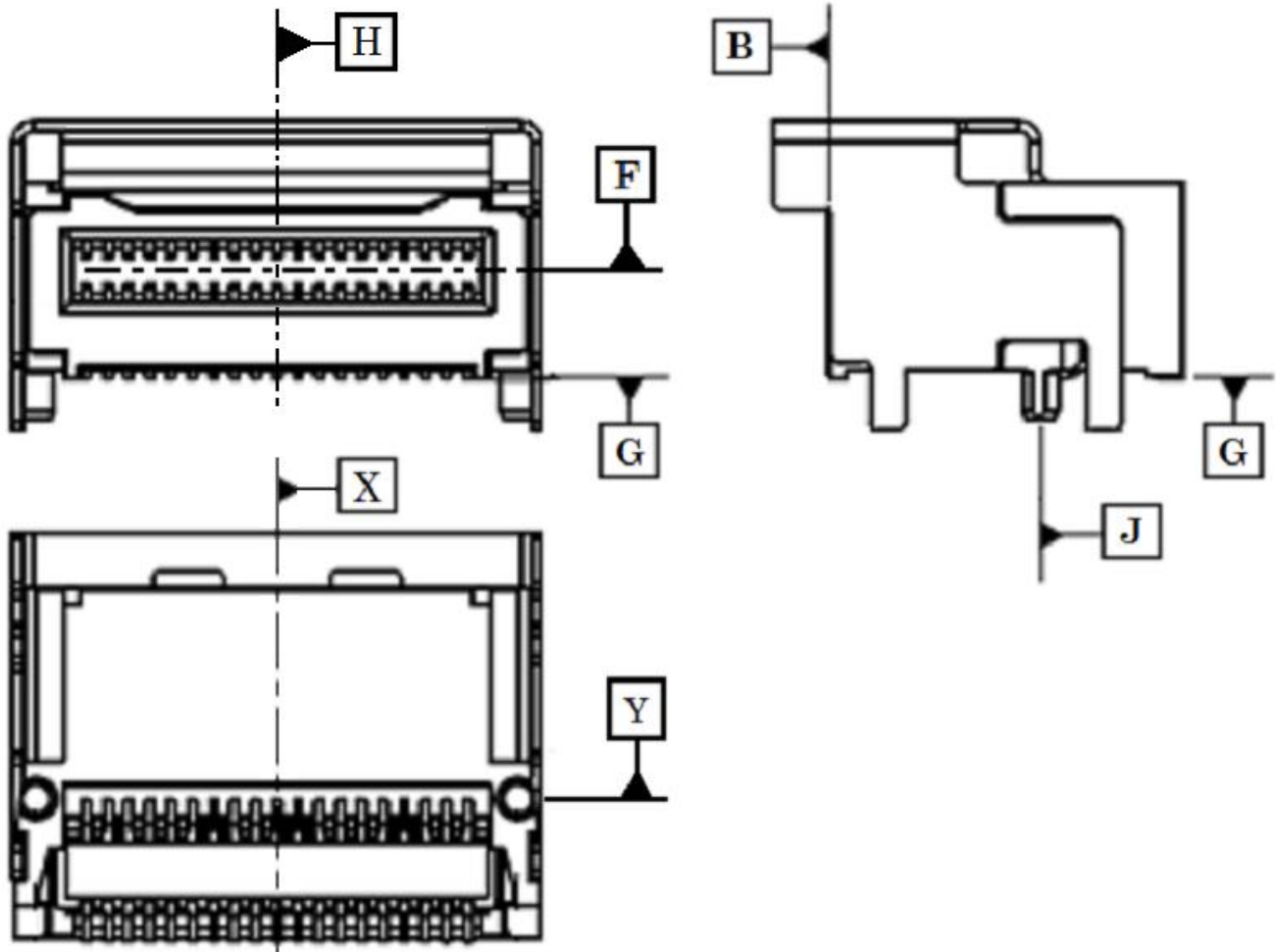

Figure 5-1 Right Angle Receptacle Datum Definitions

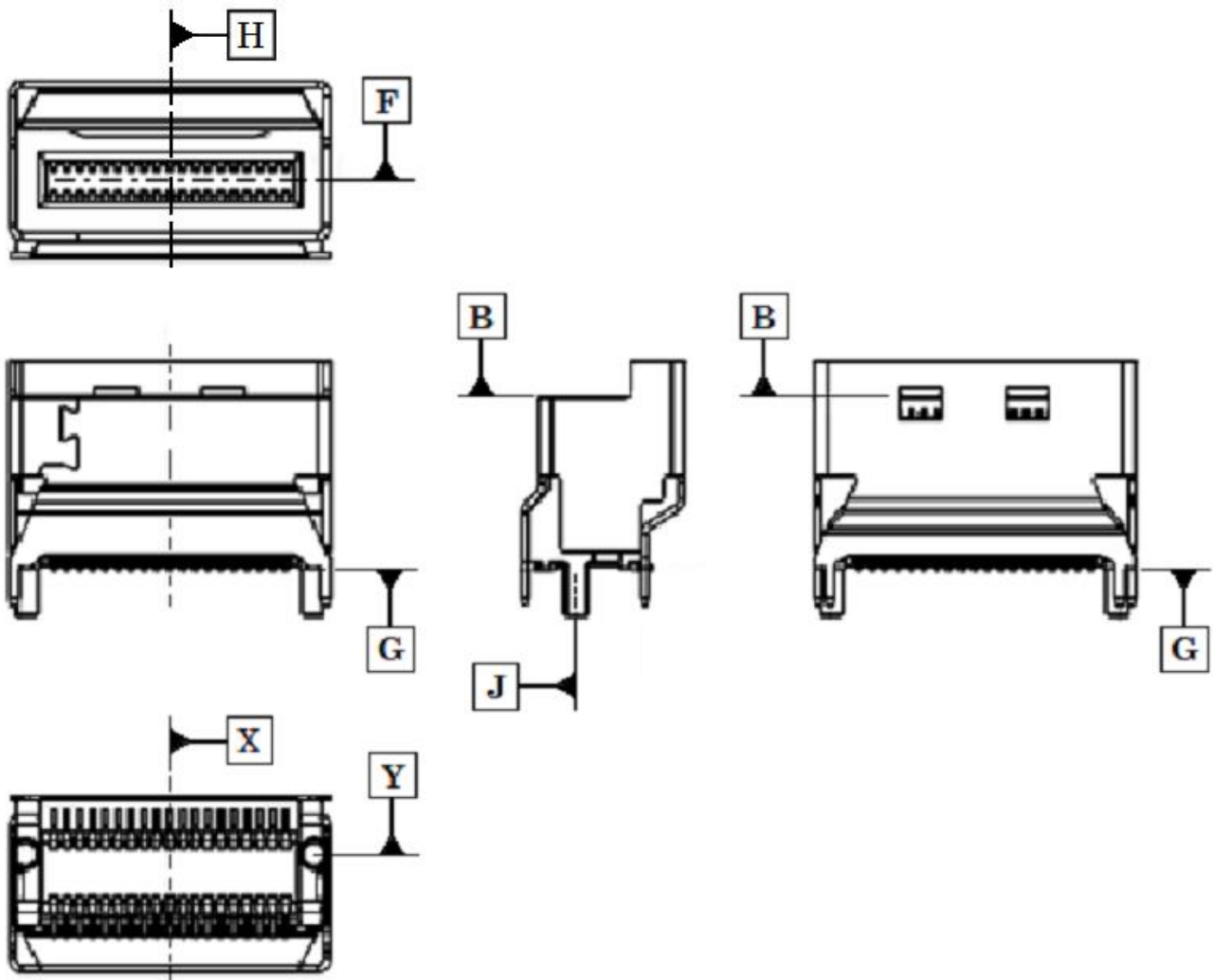

Figure 5-2 Vertical Receptacle Datum Definitions

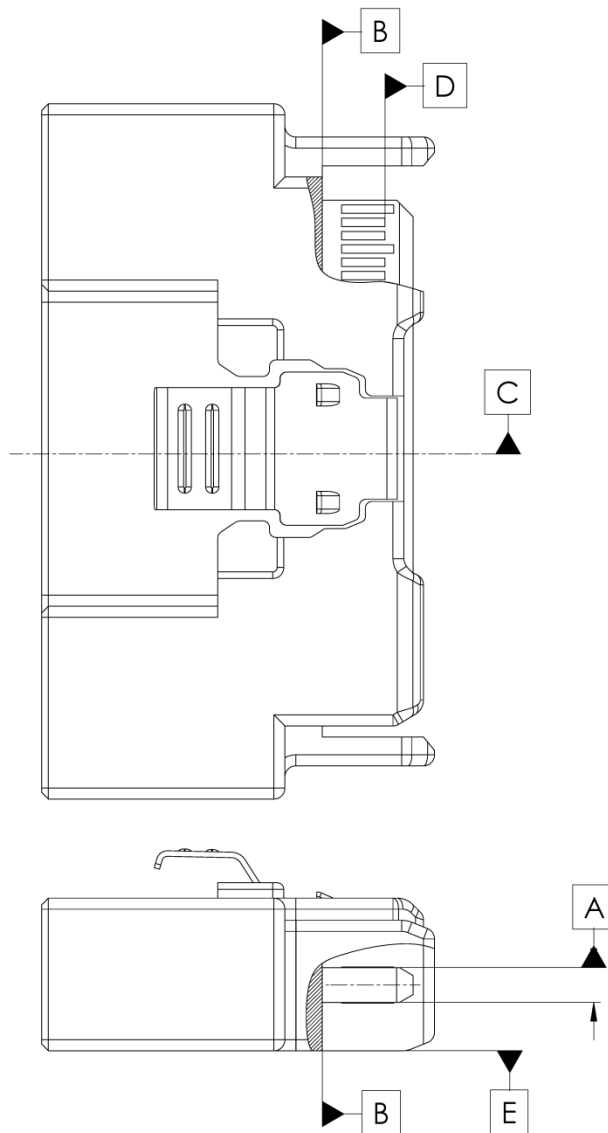

Figure 5-3 Plug Datum Definitions

Table 5-1 Datum Descriptions

Datum	Description
A	Center Plane of Paddle Card Thickness
B	Plug and Receptacle Mechanical Stop
C	Centerline of the Paddle Card / Mating Interface Centerline
D	Leading Edge of Second-mate Contacts on Paddle Card
E	Bottom Surface of Plug Body
F	Centerline of Interface Card Slot
G	Mating Surfaces to the PCB or PCB Pads
H	Centerline of the Receptacle Width
J	Centerline of the Receptacle's Locating Peg
X	Centerline Between Footprint Locating Peg Holes
Y	Plane Thru Footprint Locating Peg Hole Centers
Z	PCB Top Surface

5.2 Mechanical Description: Right Angle Connectors

5.2.1 Right Angle Connector with 38 Contacts

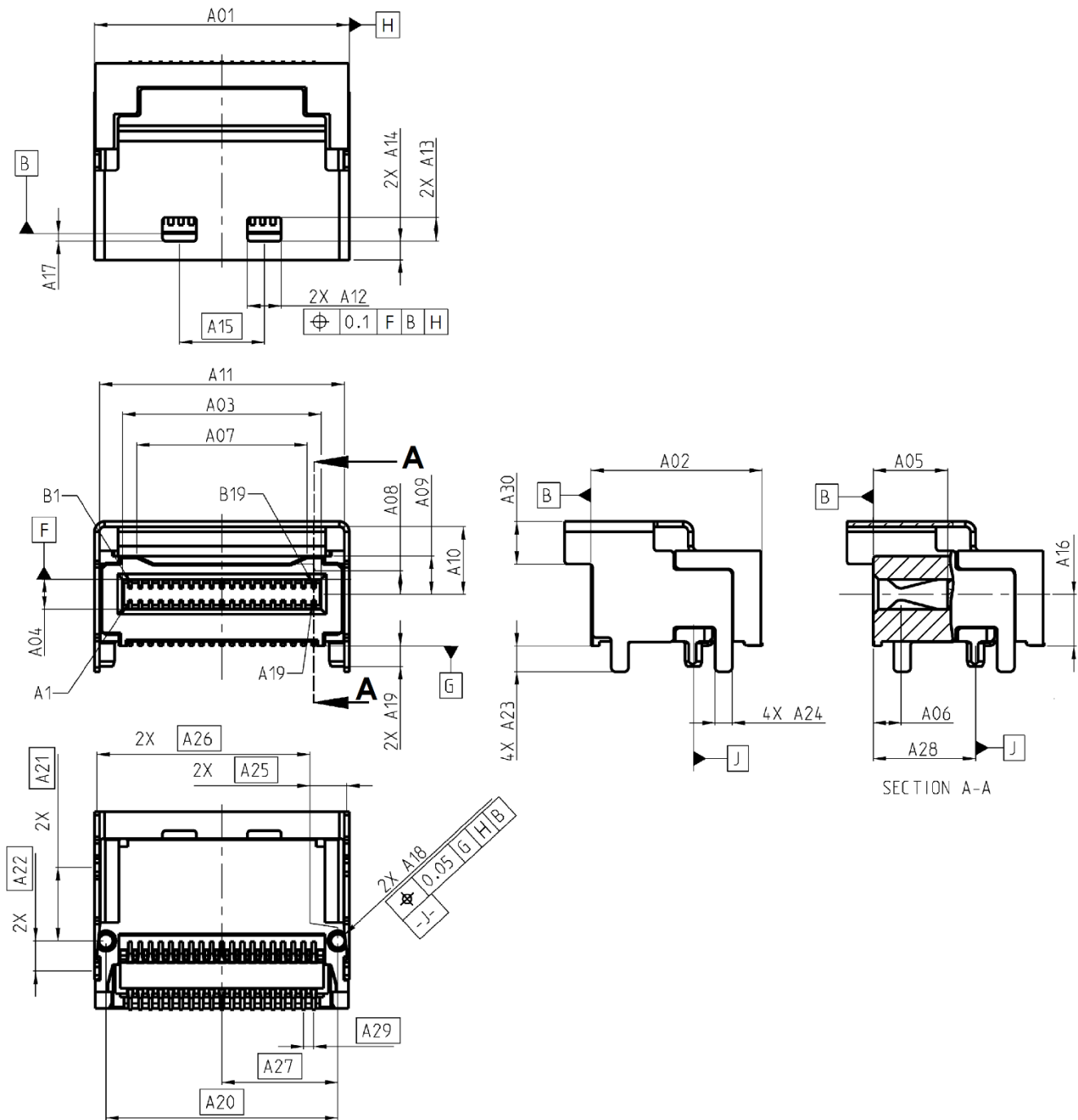

Figure 5-4 Right Angle Connector for 38 Contacts

Table 5-2 Dimensions for 38 Contact Right Angle Connectors

Designator	Description	Dimension (mm)	Tolerance +/-
A01	Right Angle Connector Width	15.20	MAX
A02	Right Angle Connector Length	10.07	±0.20
A03	Interface Card Slot Width	11.68	±0.03
A04	Interface Card Slot Height	1.80	MAX
A05	Interface Card Slot Depth	4.28	MIN
A06	Datum B (Mating Face) to Contact Point Centerline	1.65	±0.10
A07	Latch Shroud Room	10.00	MIN
A08	Interface Card Slot Centerline to Housing Wall	1.79	±0.08
A09	Interface Card Slot Centerline to Housing Wall	2.24	±0.08
A10	Latch Shroud Inner Height	3.97	±0.08
A11	Latch Shroud Inner Width	14.40	±0.08
A12	Latch Slot Width	2.00	±0.10
A13	Latch Slot Length	1.40	+0.10/-0.00
A14	Latch Slots to Latch Shroud Leading Edge	1.15	±0.05
A15	Latch Slot Spacing	5.00	Basic
A16	Datum G (PCB) to Interface Card Slot Centerline	3.05	+0.20/-0.05
A17	Datum B (Mating Face) to Leading Edge of Latch Slots	0.40	±0.10
A18	Peg Diameter	1.00	±0.05
A19	Peg Length	1.20	REF
A20	Datum J (Peg Center) to Other Peg Center	13.645	Basic
A21	Datum J (Peg Center) to First Latch Shroud Solder Pin	4.325	Basic
A22	Datum J (Peg Center) to Second Latch Shroud Solder Pin	1.775	Basic
A23	Latch Shroud Solder Pin Height	1.20	REF
A24	Latch Shroud Solder Pin Width	1.00	±0.05
A25	Datum J (Peg Center) to Right Solder Pins	0.5275	Basic
A26	Datum J (Peg Center) to Left Solder Pins	14.1725	Basic
A27	Datum J (Peg Center) to Datum H (Connector Centerline)	6.8225	Basic
A28	Datum B (Mating Face) to Datum J (Peg Center)	6.025	±0.05
A29	Contact Pitch	0.60	Basic
A30	Latch Shroud Extension Height at Opening	2.50	±0.05

5.2.2 Right Angle Connector with 74 Contacts

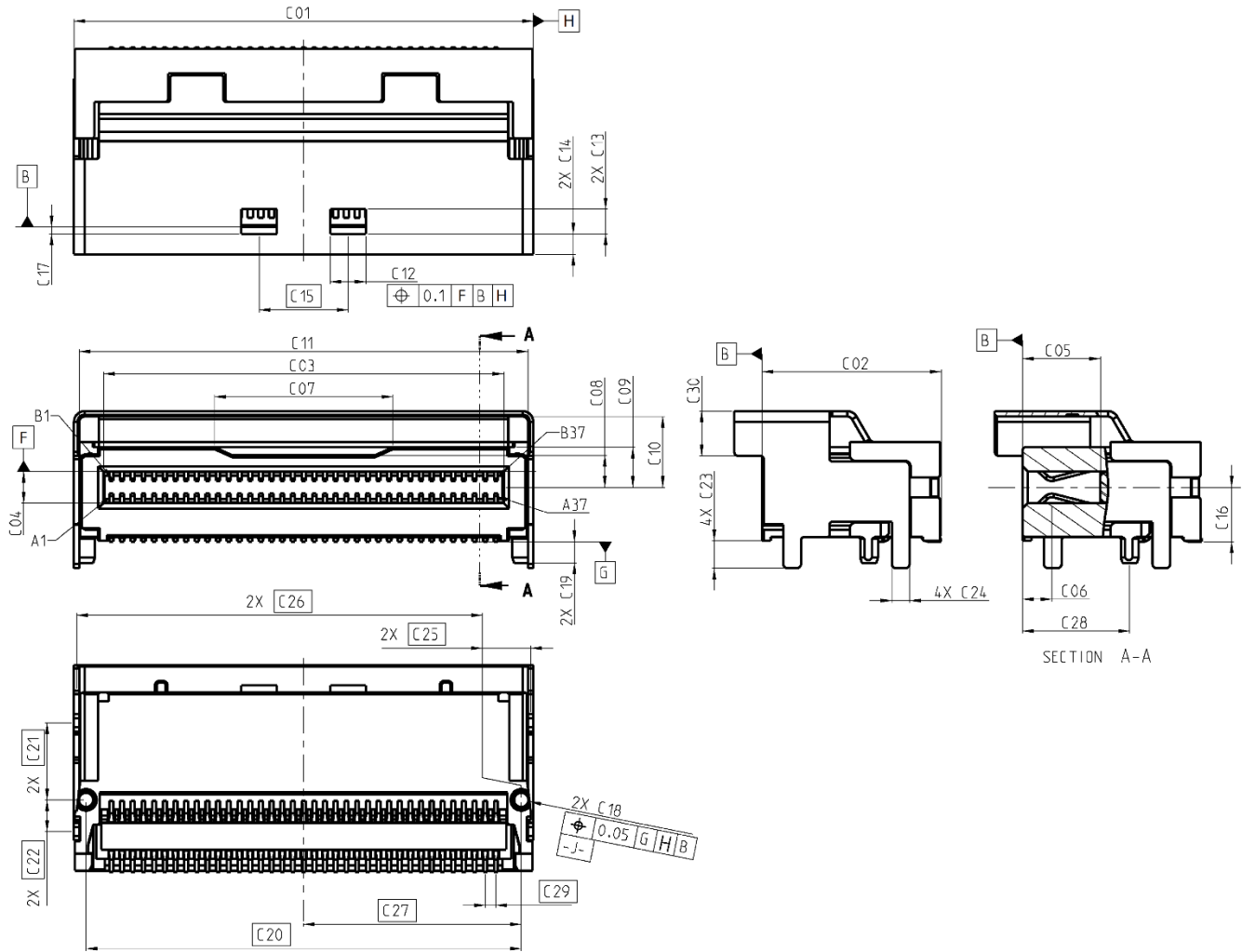

Figure 5-5 Right Angle Connector for 74 Contacts

Table 5-3 Dimensions for 74 Contact Right Angle Connectors

Designator	Description	Dimension (mm)	Tolerance +/-
C01	Right Angle Connector Width	26.00	MAX
C02	Right Angle Connector Length	10.07	±0.20
C03	Interface Card Slot Width	22.48	±0.03
C04	Interface Card Slot Height	1.80	MAX
C05	Interface Card Slot Depth	4.28	MIN
C06	Datum B (Mating Face) to Contact Point Centerline	1.65	±0.10
C07	Latch Shroud Room	10.00	MIN
C08	Interface Card Slot Centerline to Housing Wall	1.79	±0.08
C09	Interface Card Slot Centerline to Housing Wall	2.24	±0.08
C10	Latch Shroud Inner Height	3.97	±0.08
C11	Latch Shroud Inner Width	25.20	±0.08
C12	Latch Slot Width	2.00	±0.10
C13	Latch Slot Length	1.40	+0.10/-0.00
C14	Latch Slots to Latch Shroud Leading Edge	1.15	±0.05
C15	Latch Slot Spacing	5.00	Basic
C16	Datum G (PCB) to Interface Card Slot Centerline	3.05	+0.20/-0.05
C17	Datum B (Mating Face) to Leading Edge of Latch Slots	0.40	±0.10
C18	Peg Diameter	1.00	±0.05
C19	Peg Length	1.20	REF
C20	Datum J (Peg Center) to Other Peg Center	24.445	Basic
C21	Datum J (Peg Center) to First Latch Shroud Solder Pin	4.325	Basic
C22	Datum J (Peg Center) to Second Latch Shroud Solder Pin	1.775	Basic
C23	Latch Shroud Solder Pin Height	1.20	REF
C24	Latch Shroud Solder Pin Width	1.00	±0.05
C25	Datum J (Peg Center) to Right Solder Pins	0.5275	Basic
C26	Datum J (Peg Center) to Left Solder Pins	24.9725	Basic
C27	Datum J (Peg Center) to Datum H (Connector Centerline)	12.2225	Basic
C28	Datum B (Mating Face) to Datum J (Peg Center)	6.025	±0.05
C29	Contact Pitch	0.60	Basic
C30	Latch Shroud Extension Height at Opening	2.50	±0.05

5.2.3 Right Angle Connector with 124 Contacts

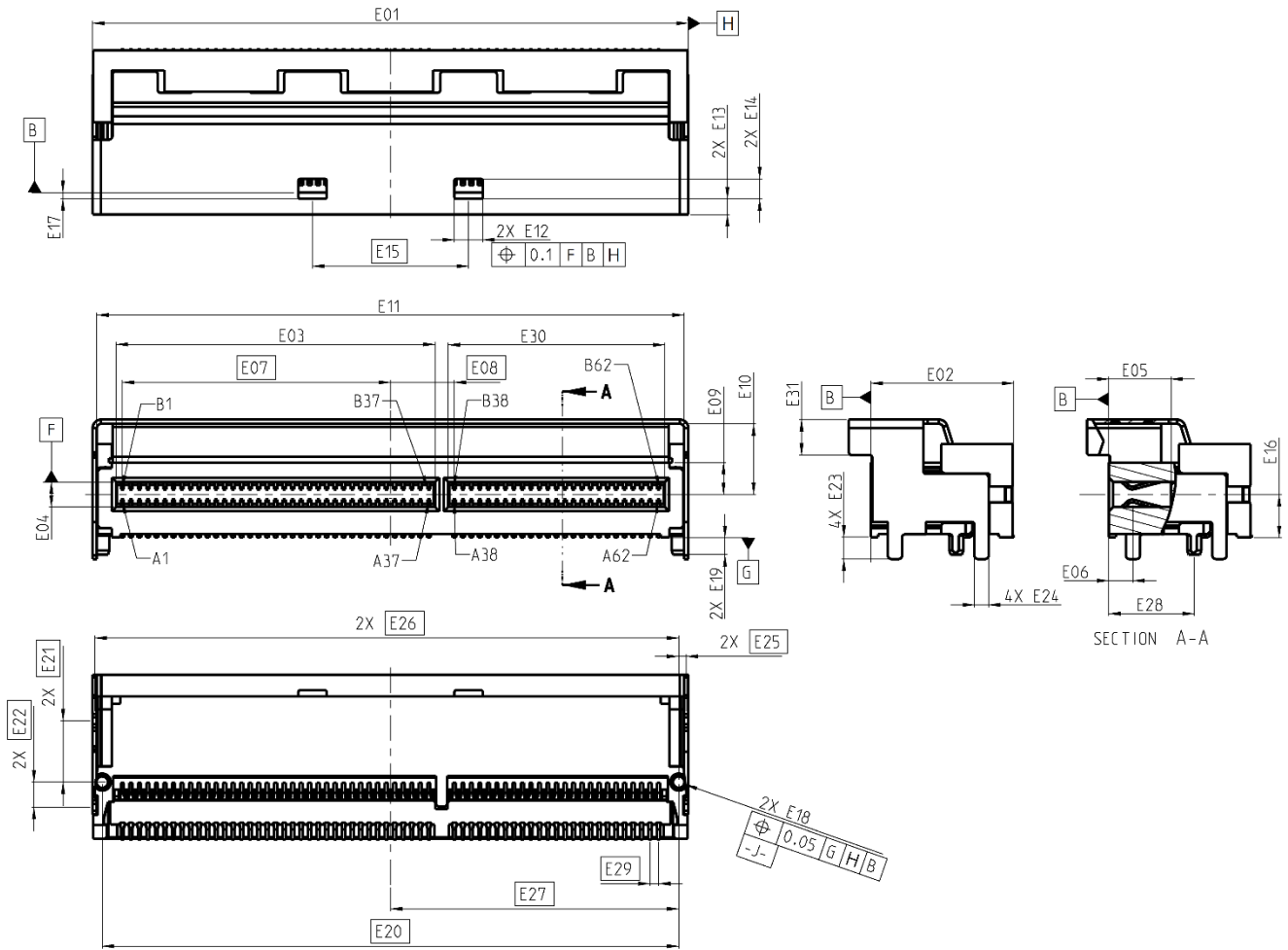

Figure 5-6 Right Angle Connector for 124 Contacts

Table 5-4 Dimensions for 124 Contact Right Angle Connectors

Designator	Description	Dimension (mm)	Tolerance +/-
E01	Right Angle Connector Width	42.20	MAX
E02	Right Angle Connector Length	10.07	±0.20
E03	Interface Card Slot Width Port 1	22.48	±0.03
E04	Interface Card Slot Height	1.80	MAX
E05	Interface Card Slot Depth	4.28	MIN
E06	Datum B (Mating Face) to Contact Point Centerline	1.65	±0.10
E07	Datum H to Pin A1/B1	18.90	Basic
E08	Datum H to Pin A38/B38	4.50	Basic
E09	Interface Card Slot Centerline to Housing Wall	2.24	±0.08
E10	Latch Shroud Inner Height	4.97	±0.08
E11	Latch Shroud Inner Width	41.40	±0.08
E12	Latch Slot Width	2.00	±0.10
E13	Latch Slots to Latch Shroud Leading Edge	1.15	±0.05
E14	Latch Slot Length	1.40	+0.10/-0.00
E15	Latch Slot Spacing	11.00	Basic
E16	Datum G (PCB) to Interface Card Slot Centerline	3.05	+0.20/0.05
E17	Datum B (Mating Face) to Leading Edge of Latch Slots	0.40	±0.10
E18	Peg Diameter	1.00	±0.05
E19	Peg Length	1.20	REF
E20	Datum J (Peg Center) to Other Peg Center	40.645	Basic
E21	Datum J (Peg Center) to First Latch Shroud Solder Pin	4.325	Basic
E22	Datum J (Peg Center) to Second Latch Shroud Solder Pin	1.775	Basic
E23	Latch Shroud Solder Pin Height	1.20	REF
E24	Latch Shroud Solder Pin Width	1.00	±0.05
E25	Datum J (Peg Center) to Right Solder Pins	0.5275	Basic
E26	Datum J (Peg Center) to Left Solder Pins	41.1725	Basic
E27	Datum J (Peg Center) to Datum H (Connector Centerline)	20.3225	Basic
E28	Datum B (Mating Face) to Datum J (Peg Center)	6.025	±0.05
E29	Contact Pitch	0.60	Basic
E30	Interface Card Slot Width – Port 2	15.28	±0.03
E31	Latch Shroud Extension Height at Opening	2.50	±0.05

5.2.4 Right Angle Connector with 148 Contacts

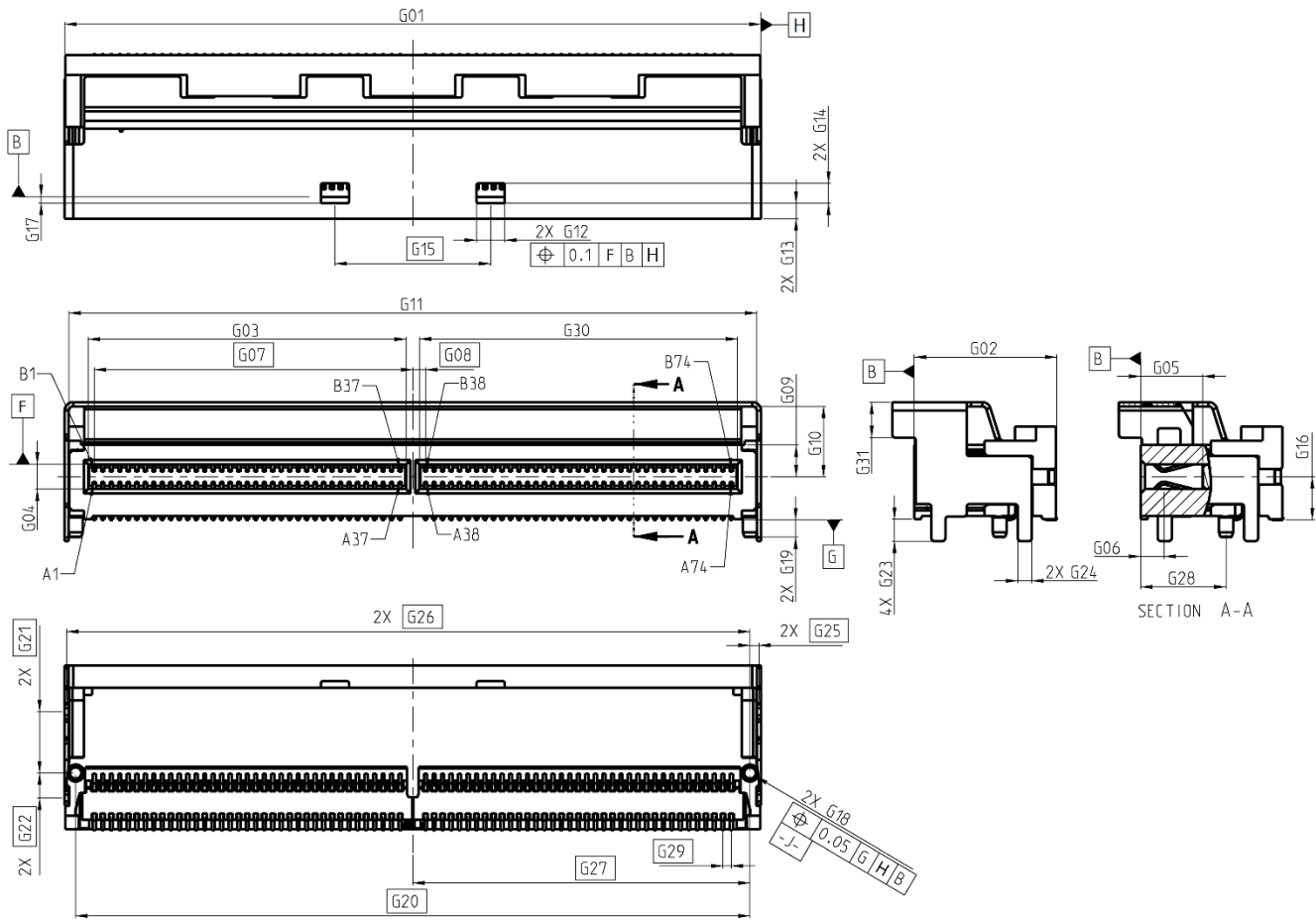

Figure 5-7 Right Angle Connector for 148 Contacts

Table 5-5 Dimensions for 148 Contact Right Angle Connectors

Designator	Description	Dimension (mm)	Tolerance +/-
G01	Right Angle Connector Width	49.40	MAX
G02	Right Angle Connector Length	10.07	±0.20
G03	Interface Card Slot Width Port 1	22.48	±0.03
G04	Interface Card Slot Height	1.80	MAX
G05	Interface Card Slot Depth	4.28	MIN
G06	Datum B (Mating Face) to Contact Point Centerline	1.65	±0.10
G07	Datum H to Pin A1/B1	22.50	Basic
G08	Datum H to Pin A38/B38	0.90	Basic
G09	Interface Card Slot Centerline to Housing Wall	2.24	±0.08
G10	Latch Shroud Inner Height	4.97	±0.08
G11	Latch Shroud Inner Width	48.60	±0.08
G12	Latch Slot Width	2.00	±0.10
G13	Latch Slots to Latch Shroud Leading Edge	1.15	±0.05
G14	Latch Slot Length	1.40	+0.10/-0.00
G15	Latch Slot Spacing	11.00	Basic
G16	Datum G (PCB) to Interface Card Slot Centerline	3.05	+0.20/-0.05
G17	Datum B (Mating Face) to Leading Edge of Latch Slots	0.40	±0.10
G18	Peg Diameter	1.00	±0.05
G19	Peg Length	1.20	REF
G20	Datum J (Peg Center) to Other Peg Center	47.845	Basic
G21	Datum J (Peg Center) to First Latch Shroud Solder Pin	4.325	Basic
G22	Datum J (Peg Center) to Second Latch Shroud Solder Pin	1.775	Basic
G23	Latch Shroud Solder Pin Height	1.20	REF
G24	Latch Shroud Solder Pin Width	1.00	±0.05
G25	Datum J (Peg Center) to Right Solder Pins	0.5275	Basic
G26	Datum J (Peg Center) to Left Solder Pins	48.3725	Basic
G27	Datum J (Peg Center) to Datum H (Connector Centerline)	23.9225	Basic
G28	Datum B (Mating Face) to Datum J (Peg Center)	6.025	±0.05
G29	Contact Pitch	0.60	Basic
G30	Interface Card Slot Width – Port 2	22.48	±0.03
G31	Latch Shroud Extension Height at Opening	2.50	±0.05

5.3 Mechanical Description: Vertical Connectors

5.3.1 Vertical Connector with 38 Contacts

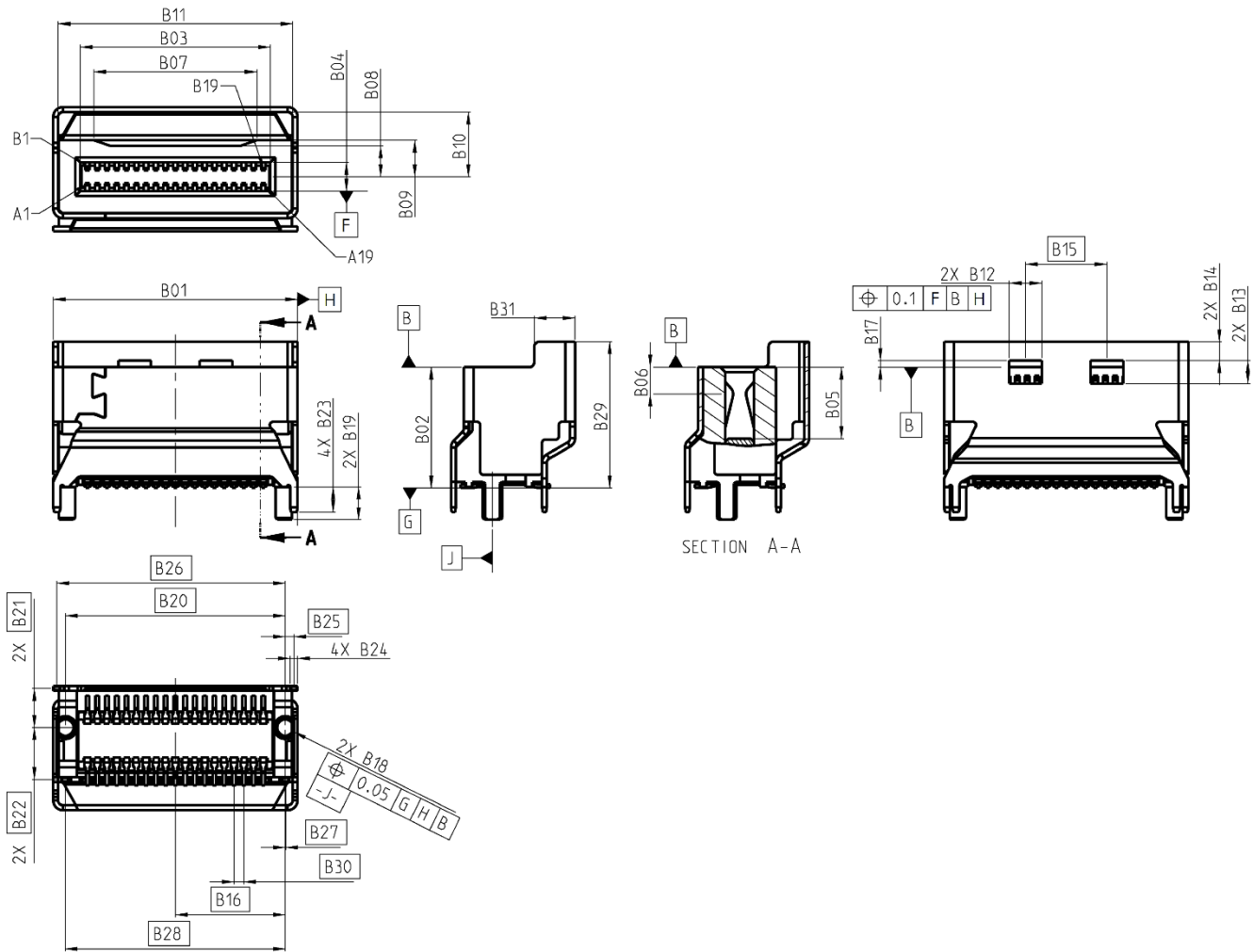

Figure 5-8 Vertical Connector for 38 Contacts

Table 5-6 Dimensions for 38 Contact Vertical Connectors

Designator	Description	Dimension (mm)	Tolerance +/-
B01	Vertical Connector Width	15.20	MAX
B02	Datum B (Mating Face) Height from PCB	7.40	±0.20
B03	Interface Card Slot Width	11.68	±0.03
B04	Interface Card Slot Height	1.80	MAX
B05	Interface Card Slot Depth	4.28	MIN
B06	Datum B (Mating Face) to Contact Point Centerline	1.65	±0.10
B07	Latch Shroud Room	10.00	MIN
B08	Interface Card Slot Centerline to Housing Wall	1.89	±0.08
B09	Interface Card Slot Centerline to Housing Wall	2.24	±0.08
B10	Latch Shroud Inner Height	3.97	±0.08
B11	Latch Shroud Inner Width	14.40	±0.08
B12	Latch Slot Width	2.00	REF
B13	Latch Slot Length	1.40	+0.10/-0.00
B14	Latch Slots to Latch Shroud Leading Edge	1.15	±0.05
B15	Latch Slots Spacing	5.00	Basic
B16	Datum J (Peg Center) to Datum H (Connector Centerline)	6.75	Basic
B17	Datum B (Mating Face) to Leading Edge of Latch Slots	0.40	±0.10
B18	Peg Diameter	1.20	±0.05
B19	Peg Length	1.20	REF
B20	Datum J (Peg Center) to Other Peg Center	13.50	Basic
B21	Datum J (Peg Center) to First Latch Shroud Solder Pin	2.40	Basic
B22	Datum J (Peg Center) to Second Latch Shroud Solder Pin	3.19	Basic
B23	Latch Shroud Solder Pin Height	1.20	REF
B24	Latch Shroud Solder Pin Width	0.45	±0.05
B25	Datum J (Peg Center) to Right Solder Pin	0.525	Basic
B26	Datum J (Peg Center) to Left Solder Pin	14.025	Basic
B27	Datum J (Peg Center) to Right Solder Pin	0.025	Basic
B28	Datum J (Peg Center) to Left Solder Pin	13.525	Basic
B29	Vertical Connector Height	8.95	±0.30
B30	Contact Pitch	0.60	Basic
B31	Latch Shroud Extension Width at Side	2.50	±0.05

5.3.2 Vertical Connector with 74 Contacts

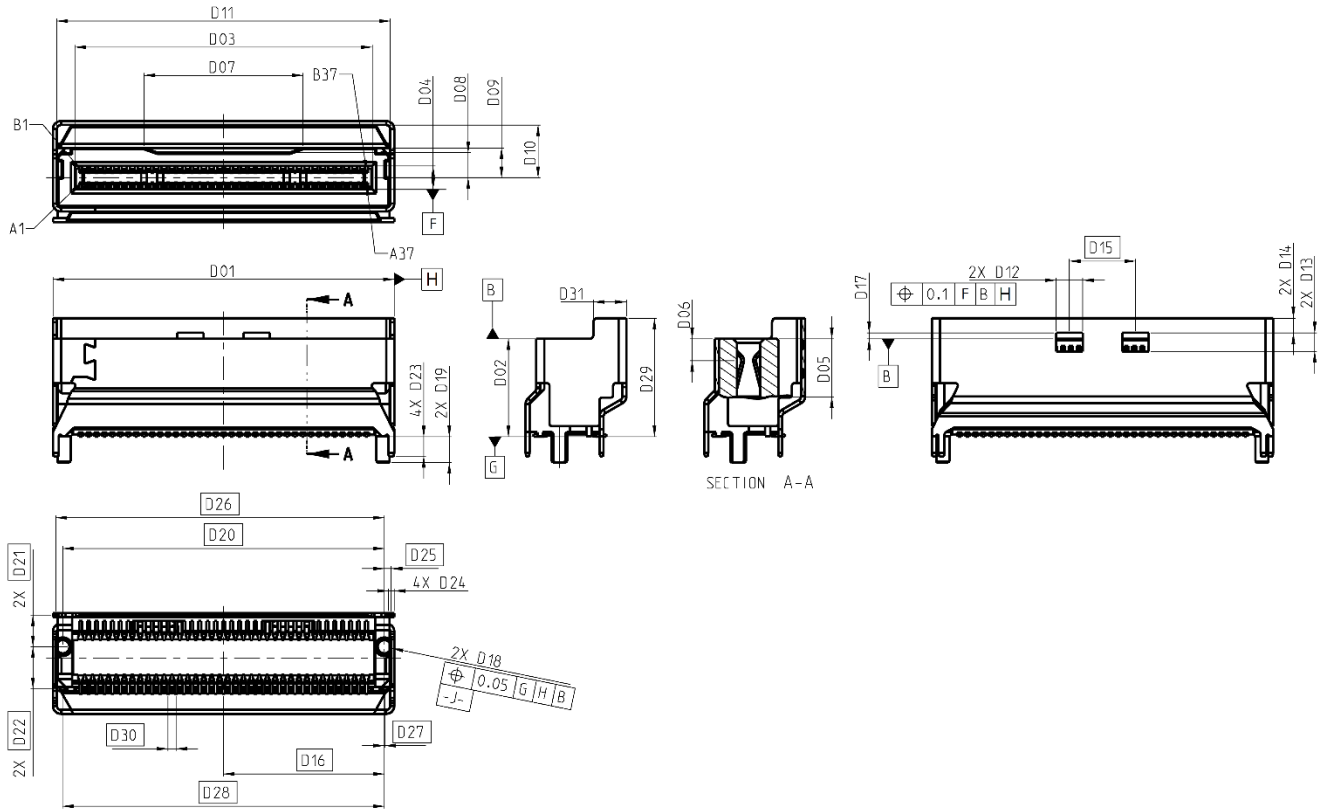

Figure 5-9 Vertical Connector for 74 Contacts

Table 5-7 Dimensions for 74 Contact Vertical Connectors

Designator	Description	Dimension (mm)	Tolerance +/-
D01	Vertical Connector Width	26.00	MAX
D02	Datum B (Mating Face) Height from PCB	7.40	±0.20
D03	Interface Card Slot Width	22.48	±0.03
D04	Interface Card Slot Height	1.80	MAX
D05	Interface Card Slot Depth	4.28	MIN
D06	Datum B (Mating Face) to Contact Point Centerline	1.65	±0.10
D07	Latch Shroud Room	10.00	MIN
D08	Interface Card Slot Centerline to Housing Wall	1.89	±0.08
D09	Interface Card Slot Centerline to Housing Wall	2.24	±0.08
D10	Latch Shroud Inner Height	3.97	±0.08
D11	Latch Shroud Inner Width	25.20	±0.08
D12	Latch Slot Width	2.00	±0.10
D13	Latch Slot Length	1.40	+0.10/-0.00
D14	Latch Slots to Latch Shroud Leading Edge	1.15	±0.05
D15	Latch Slots Spacing	5.00	Basic
D16	Datum J (Peg Center) to Datum H (Connector Centerline)	12.15	Basic
D17	Datum B (Mating Face) to Leading Edge of Latch Slots	0.40	±0.10
D18	Peg Diameter	1.20	±0.05
D19	Peg Length	1.20	REF
D20	Datum J (Peg Center) to Other Peg Center	24.30	Basic
D21	Datum J (Peg Center) to First Latch Shroud Solder Pin	2.40	Basic
D22	Datum J (Peg Center) to Second Latch Shroud Solder Pin	3.19	Basic
D23	Latch Shroud Solder Pin Height	1.20	REF
D24	Latch Shroud Solder Pin Width	0.45	±0.05
D25	Datum J (Peg Center) to Right Solder Pin	0.525	Basic
D26	Datum J (Peg Center) to Left Solder Pin	24.825	Basic
D27	Datum J (Peg Center) to Right Solder Pin	0.025	Basic
D28	Datum J (Peg Center) to Left Solder Pin	24.325	Basic
D29	Vertical Connector Height	8.95	±0.30
D30	Contact Pitch	0.60	Basic
D31	Latch Shroud Extension Width at Side	2.50	±0.05

5.3.3 Vertical Connector with 124 Contacts

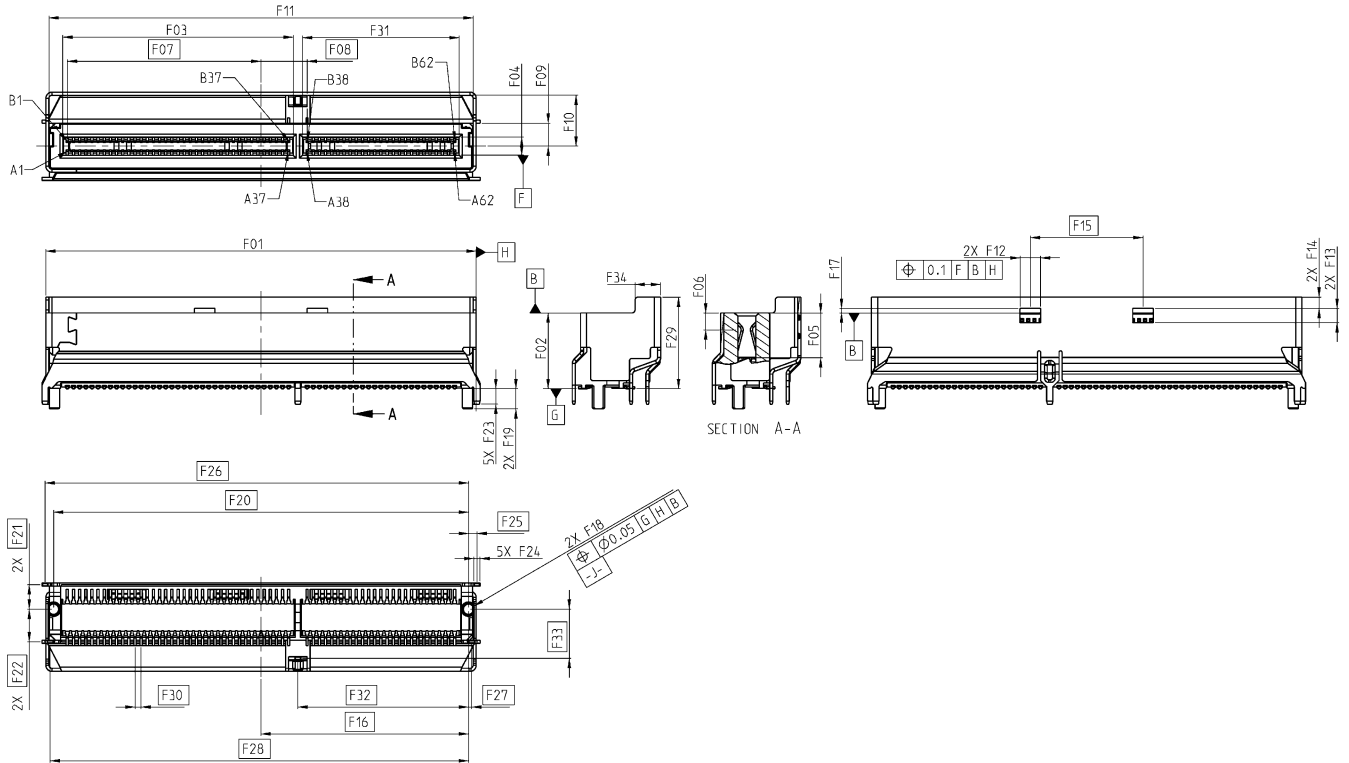

Figure 5-10 Vertical Connector for 124 Contacts

Table 5-8 Dimensions for 124 Contact Vertical Connectors

Designator	Description	Dimension (mm)	Tolerance +/-
F01	Vertical Connector Width	42.20	MAX
F02	Datum B (Mating Face) Height from PCB	7.40	±0.20
F03	Interface Card Slot Width – Port 1	22.48	±0.03
F04	Interface Card Slot Height	1.80	MAX
F05	Interface Card Slot Depth	4.28	MIN
F06	Datum B (Mating Face) to Contact Point Centerline	1.65	±0.10
F07	Datum H (Connector Centerline) to Pin A1/B1	18.90	Basic
F08	Datum H (Connector Centerline) to Pin A38/B38	4.50	Basic
F09	Interface Card Slot Centerline to Housing Wall	2.24	±0.08
F10	Latch Shroud Inner Height	4.97	±0.08
F11	Latch Shroud Inner Width	41.40	±0.08
F12	Latch Slot Width	2.00	±0.10
F13	Latch Slot Length	1.40	+0.10/-0.00
F14	Latch Slots to Latch Shroud Leading Edge	1.15	±0.05
F15	Latch Slots Spacing	11.00	Basic
F16	Datum J (Peg Center) to Datum H (Connector Centerline)	20.25	Basic
F17	Datum B (Mating Face) to Leading Edge of Latch Slots	0.40	±0.10
F18	Peg Diameter	1.20	±0.05
F19	Peg Length	1.20	REF
F20	Datum J (Peg Center) to Other Peg Center	40.50	Basic
F21	Datum J (Peg Center) to First Latch Shroud Solder Pin	2.40	Basic
F22	Datum J (Peg Center) to Second Latch Shroud Solder Pin	3.19	Basic
F23	Latch Shroud Solder Pin Height	1.20	REF
F24	Latch Shroud Solder Pin Width	0.60	±0.05
F25	Datum J (Peg Center) to Right Solder Pin	0.825	Basic
F26	Datum J (Peg Center) to Left Solder Pin	41.325	Basic
F27	Datum J (Peg Center) to Right Solder Pin	0.325	Basic
F28	Datum J (Peg Center) to Left Solder Pin	40.825	Basic
F29	Vertical Connector Height	8.95	±0.30
F30	Contact Pitch	0.60	Basic
F31	Interface Card Slot Width – Port 2	15.28	±0.03
F32	Datum J (Peg) to Center of Shroud Solder Pin	16.65	Basic
F33	Datum J (Peg) to Center of Shroud Solder Pin	4.79	Basic
F34	Latch Shroud Extension Width at Side	2.50	±0.05

5.3.4 Vertical Connector with 148 Contacts

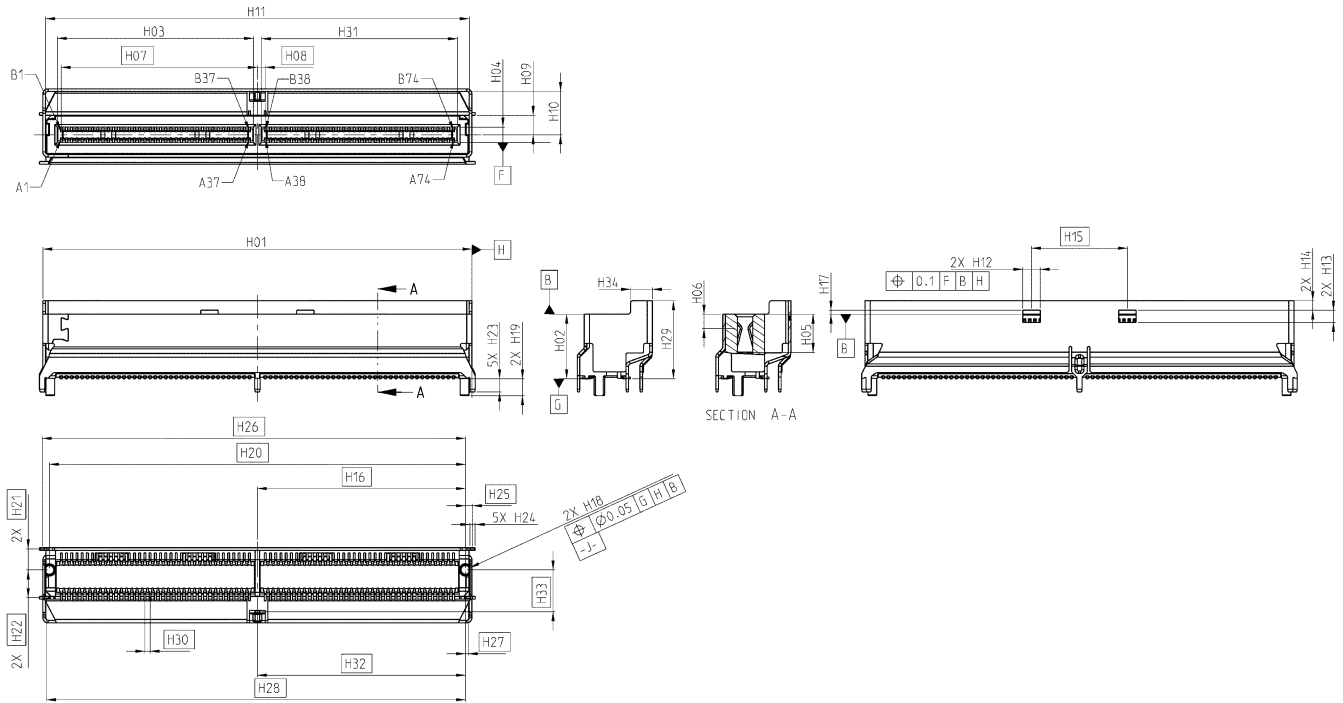

Figure 5-11 Vertical Connector for 148 Contacts

Table 5-9 Dimensions for 148 Contact Vertical Connectors

Designator	Description	Dimension (mm)	Tolerance +/-
H01	Vertical Connector Width	49.40	MAX
H02	Datum B (Mating Face) Height from PCB	7.40	±0.20
H03	Interface Card Slot Width – Port 1	22.48	±0.03
H04	Interface Card Slot Height	1.80	MAX
H05	Interface Card Slot Depth	4.28	MIN
H06	Datum B (Mating Face) to Contact Point Centerline	1.65	±0.10
H07	Datum H (Connector Centerline) to Pin A1/B1	22.50	Basic
H08	Datum H (Connector Centerline) to Pin A38/B38	0.90	Basic
H09	Interface Card Slot Centerline to Housing Wall	2.24	±0.08
H10	Latch Shroud Inner Height	4.97	±0.08
H11	Latch Shroud Inner Width	48.60	±0.08
H12	Latch Slot Width	2.00	±0.10
H13	Latch Slot Length	1.40	+0.10/-0.00
H14	Latch Slots to Latch Shroud Leading Edge	1.15	±0.05
H15	Latch Slots Spacing	11.00	Basic
H16	Datum J (Peg Center) to Datum H (Connector Centerline)	23.85	Basic
H17	Datum B (Mating Face) to Leading Edge of Latch Slots	0.40	±0.10
H18	Peg Diameter	1.20	±0.05
H19	Peg Length	1.20	REF
H20	Datum J (Peg Center) to Other Peg Center	47.70	Basic
H21	Datum J (Peg Center) to First Latch Shroud Solder Pin	2.40	Basic
H22	Datum J (Peg Center) to Second Latch Shroud Solder Pin	3.19	Basic
H23	Latch Shroud Solder Pin Height	1.20	REF
H24	Latch Shroud Solder Pin Width	0.60	±0.05
H25	Datum J (Peg Center) to Right Solder Pin	0.825	Basic
H26	Datum J (Peg Center) to Left Solder Pin	48.525	Basic
H27	Datum J (Peg Center) to Right Solder Pin	0.325	Basic
H28	Datum J (Peg Center) to Left Solder Pin	48.025	Basic
H29	Vertical Connector Height	8.95	±0.30
H30	Contact Pitch	0.60	Basic
H31	Interface Card Slot Width – Port 2	22.48	±0.03
H32	Datum J (Peg) to Center of Shroud Solder Pin	23.85	Basic
H33	Datum J (Peg) to Center of Shroud Solder Pin	4.79	Basic
H34	Latch Shroud Extension Width at Side	2.50	±0.05

5.4 Outer Locus of the Right Angle Connector and Vertical Connector Mating Contacts

Figure 5-12 through Figure 5-15 show the outer locus of the connector contacts at the mating interface.

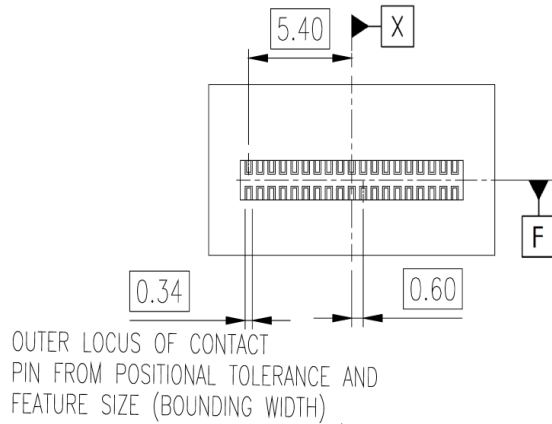

Figure 5-12 Outer Locus of 38P Connector Mating Contact Pins

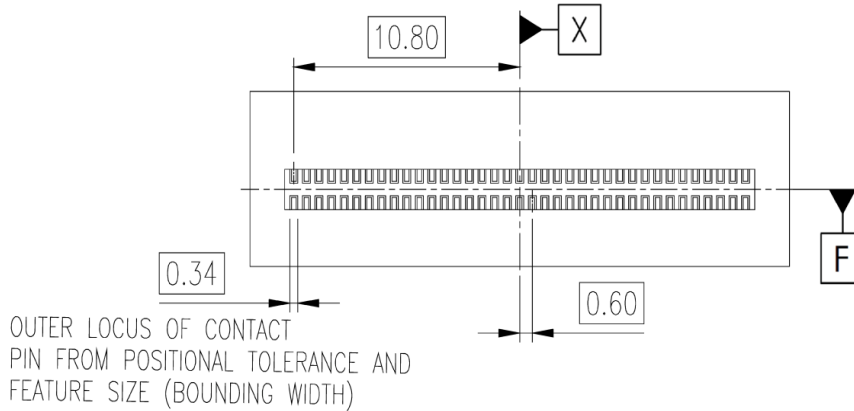

Figure 5-13 Outer Locus of 74P Connector Mating Contact Pins

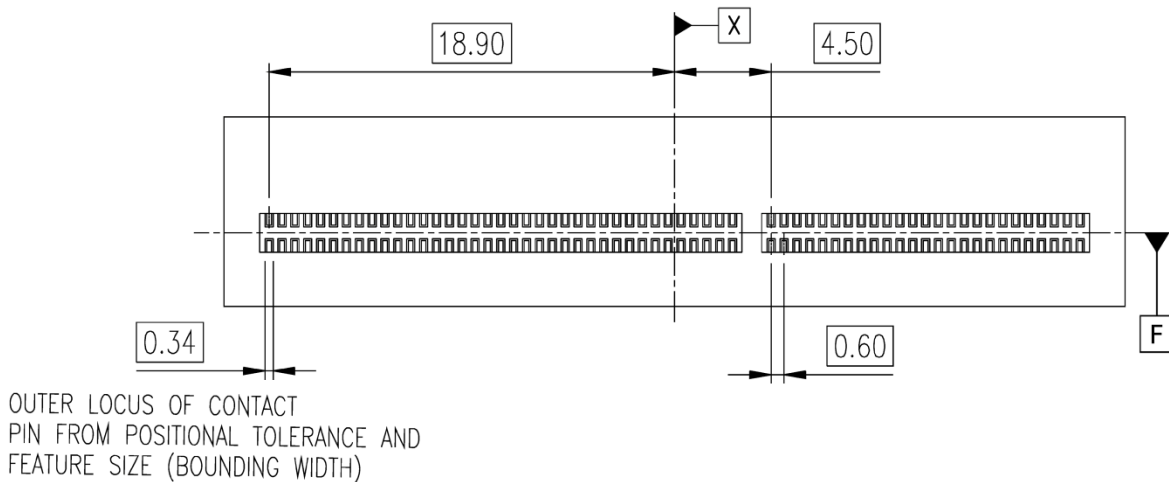

Figure 5-14 Outer Locus of 124P Connector Mating Contact Pins

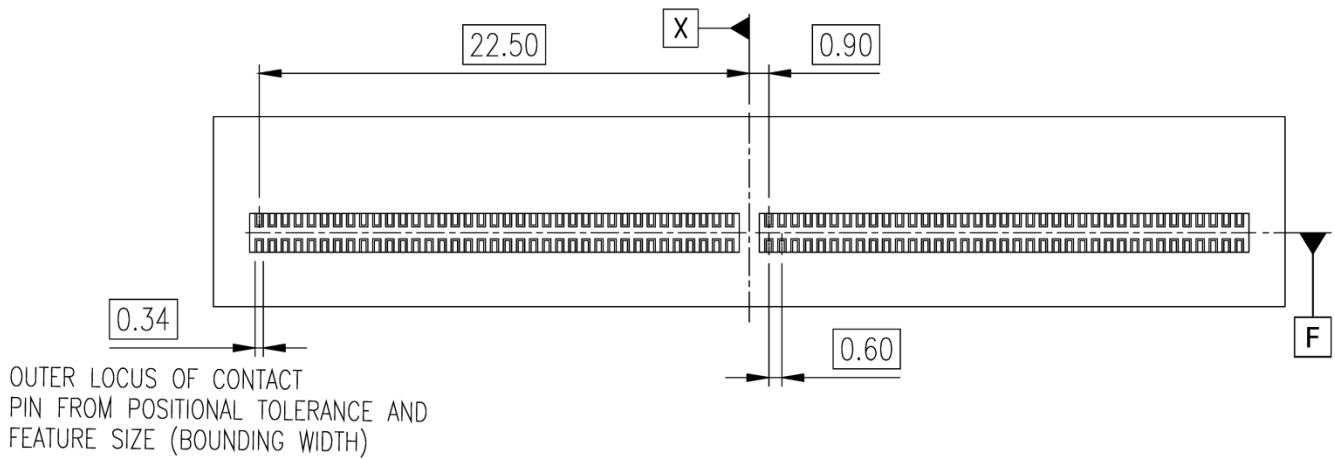

Figure 5-15 Outer Locus of 148P Connector Mating Contact Pins

5.5 Outer Locus of the SMT Leads

Figure 5-16 through Figure 5-23 show the outer locus of the flat surfaces of the SMT leads that are intended to mate with the applicable PCB footprint pads for receptacle each connector type.

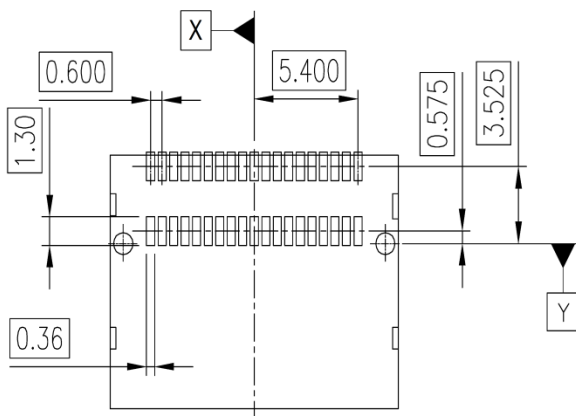

Figure 5-16 Outer Locus of 38P Right Angle Connector SMT Leads

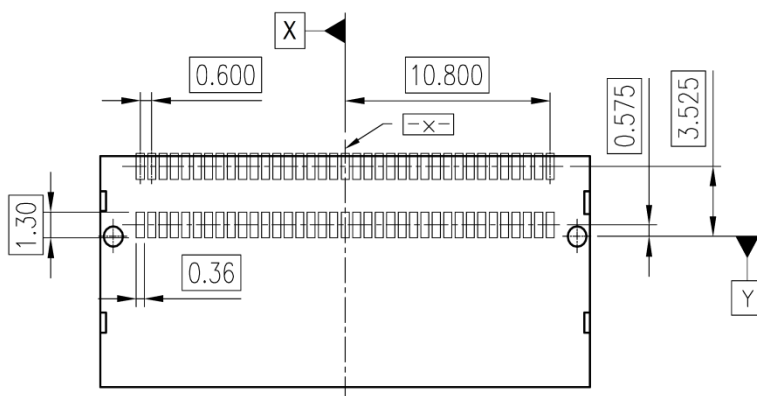

Figure 5-17 Outer Locus of 74P Right Angle Connector SMT Leads

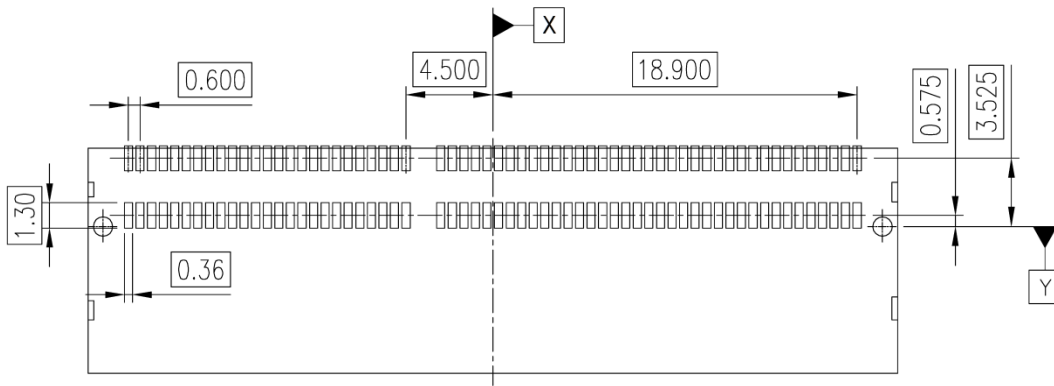

Figure 5-18 Outer Locus of 124P Right Angle Connector SMT Leads

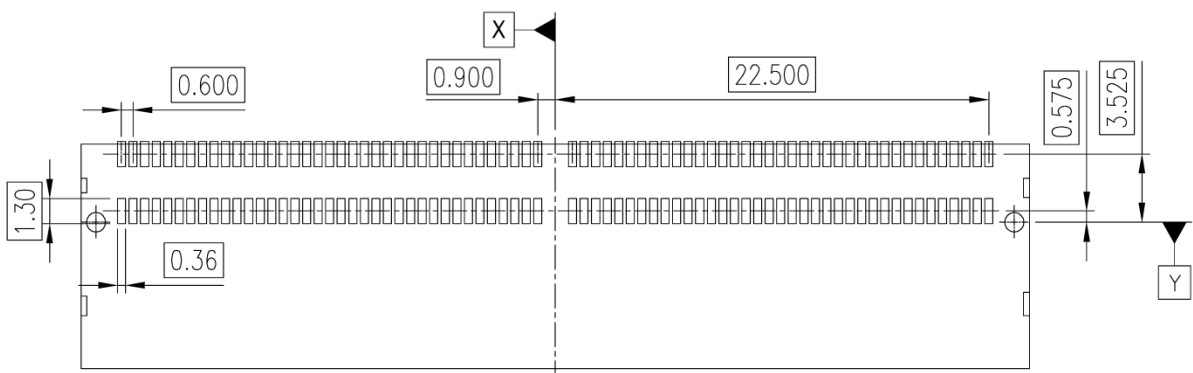

Figure 5-19 Outer Locus of 148P Right Angle Connector SMT Leads

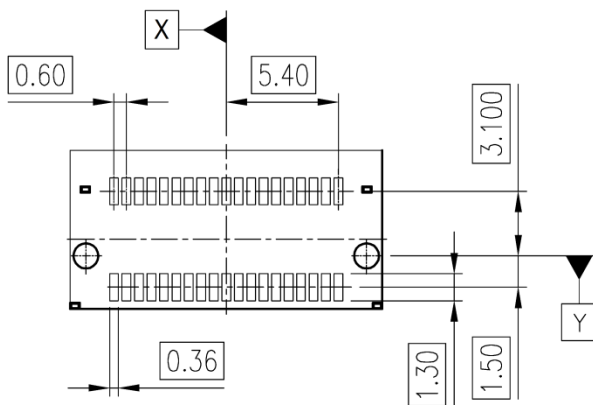

Figure 5-20 Outer Locus of 38P Vertical Connector SMT Leads

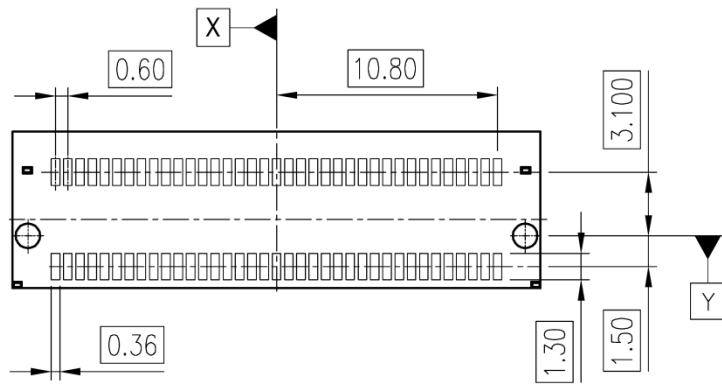

Figure 5-21 Outer Locus of 74P Vertical Connector SMT Leads

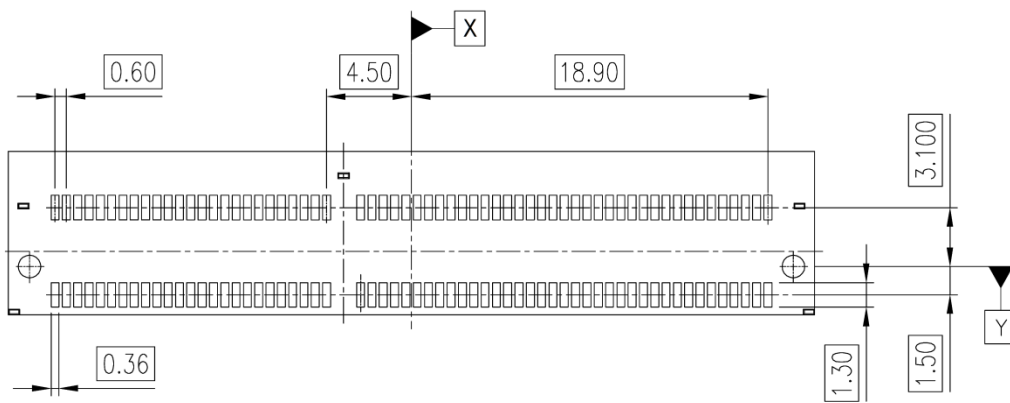

Figure 5-22 Outer Locus of 124P Vertical Connector SMT Leads

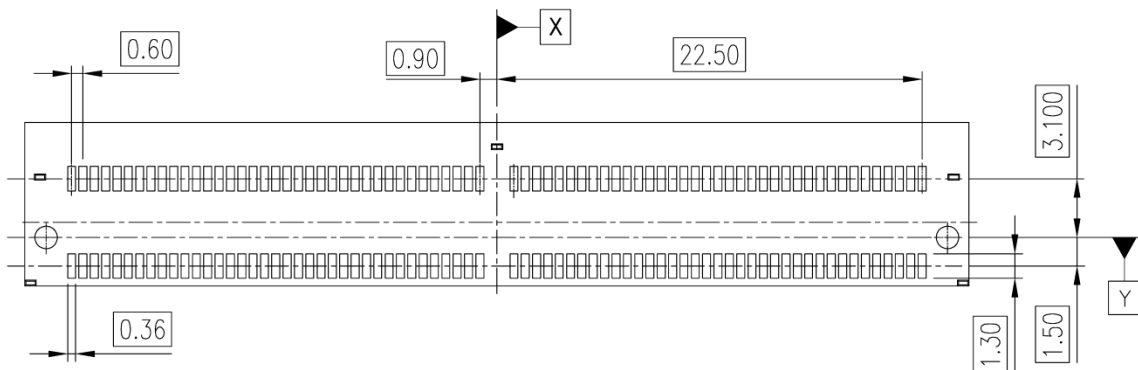

Figure 5-23 Outer Locus of 148P Vertical Connector SMT Leads

6. Module Mechanical Specification

6.1 Overview

Refer back to section 5.1.1 for definitions of datums used throughout the following sections.

6.2 Mechanical Description: Plug Modules

6.2.1 Plug Connector with 38 Contacts

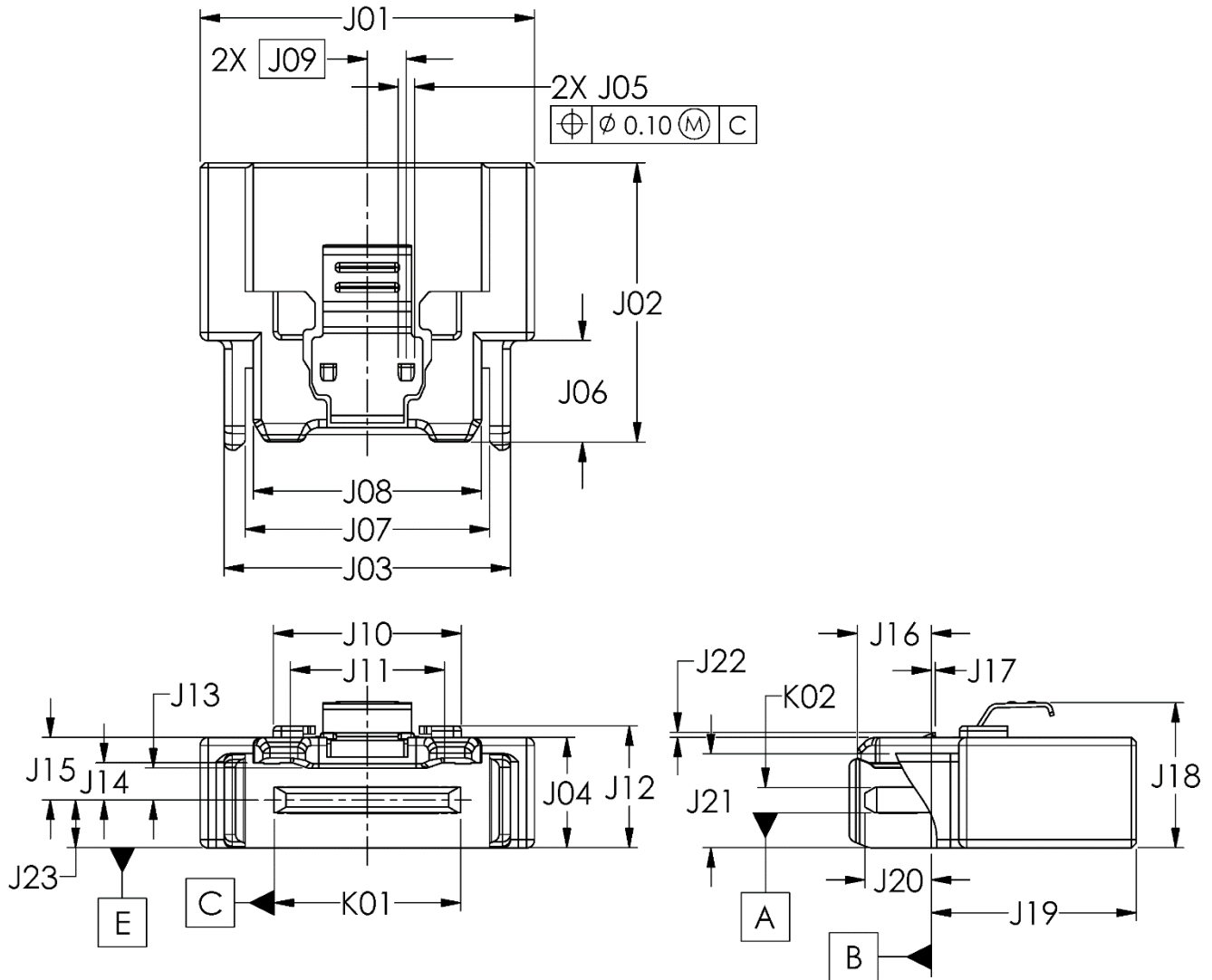

Figure 6-1 Straight Plug with Side Anti-skew Flanges for 38 Contacts

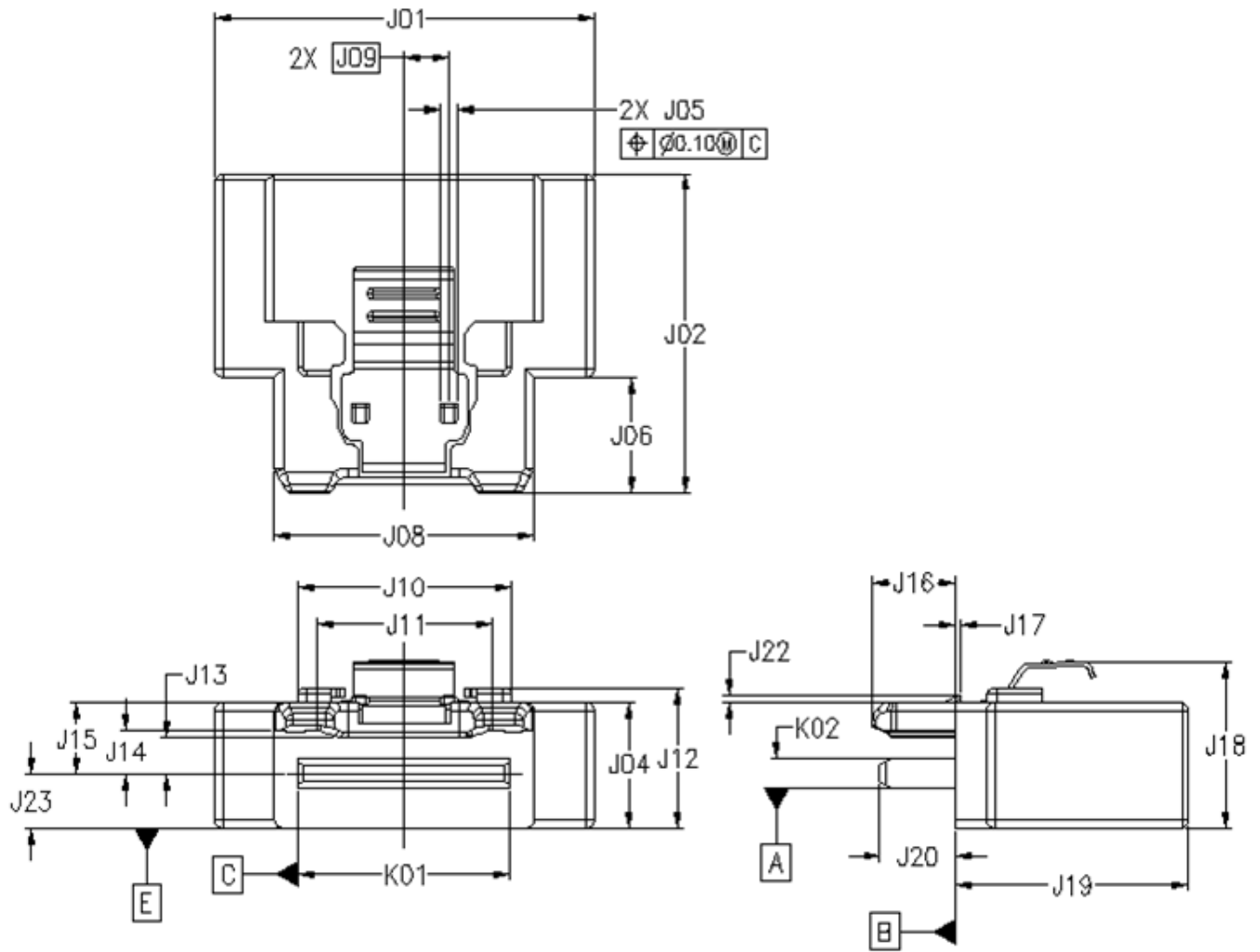

Figure 6-2 Straight Plug with No Side Flanges for 38 Contacts

Table 6-1 Dimensions for 38 Contact Plug Connectors

Designator	Description		Dimension (mm)	Tolerance +/-
K01	Interface Card Width		11.60	±0.05
K02	Paddle Card Thickness		1.57	±0.15
J01	Plug Body Rear Width (See Note 1)	with Side Anti-skew Flanges	20.80	MAX
		with No Side Anti-skew Flanges	15.15	±0.15
J02	Straight Plug Length		17.35	REF
J03	Plug Body Front Width (See Note 2)	with Side Anti-skew Flanges	17.80	±0.15
		with No Side Anti-skew Flanges	Equal to dimension J08	
J04	Plug Body Thickness		6.86	±0.10
J05	Latch Tab Width		1.00	±0.10
J06	Shroud Length		6.30	±0.10
J07	Anti-skew Flange Width (See Note 3)		15.30	+0.20/-0.10
J08	Shroud Width		14.32	MAX
J09	Datum C (Interface Centerline) to Latch Tab Center		2.42	Basic
J10	Latch Stopper Width		11.70	±0.20
J11	Bump of Shroud Width		9.59	MAX
J12	Datum E to Latch Stopper		7.58	REF
J13	Datum A to Bottom Surface of Shroud		1.87	MIN
J14	Datum A to Middle Surface of Shroud		2.32	MIN
J15	Datum A to Top Surface of Shroud		3.89	MAX
J16	Datum B to Edge of Shroud		4.60	±0.10
J17	Datum B to Back Edge of Latch Tab		0.24	+0.10/-0.20
J18	Datum E to Latch		9.00	REF
J19	Datum B to Plug Body End		12.75	REF
J20	Datum B to Card Edge		4.13	±0.13
J21	Datum E to Top Surface of Anti-skew Flange (See Note 3)		6.86	±0.10
J22	Top Surface of Shroud to Latch Tab Height	(When Free)	0.30	MIN
		(For Release)	0.05	MAX
J23	Datum A to Datum E		3.10	MAX

NOTES:

1. The narrow option allows for use in limited width applications. The narrow option does not include the Side Anti-skew Flanges and the J01 dimension is reduced.
2. For the narrow option where the Side Anti-skew Flange features are not included, this dimension equals dimension J08.
3. For the narrow option where the Side Anti-skew Flange features are not included, these dimensions are not used.

6.2.2 Plug Connector with 74 Contacts

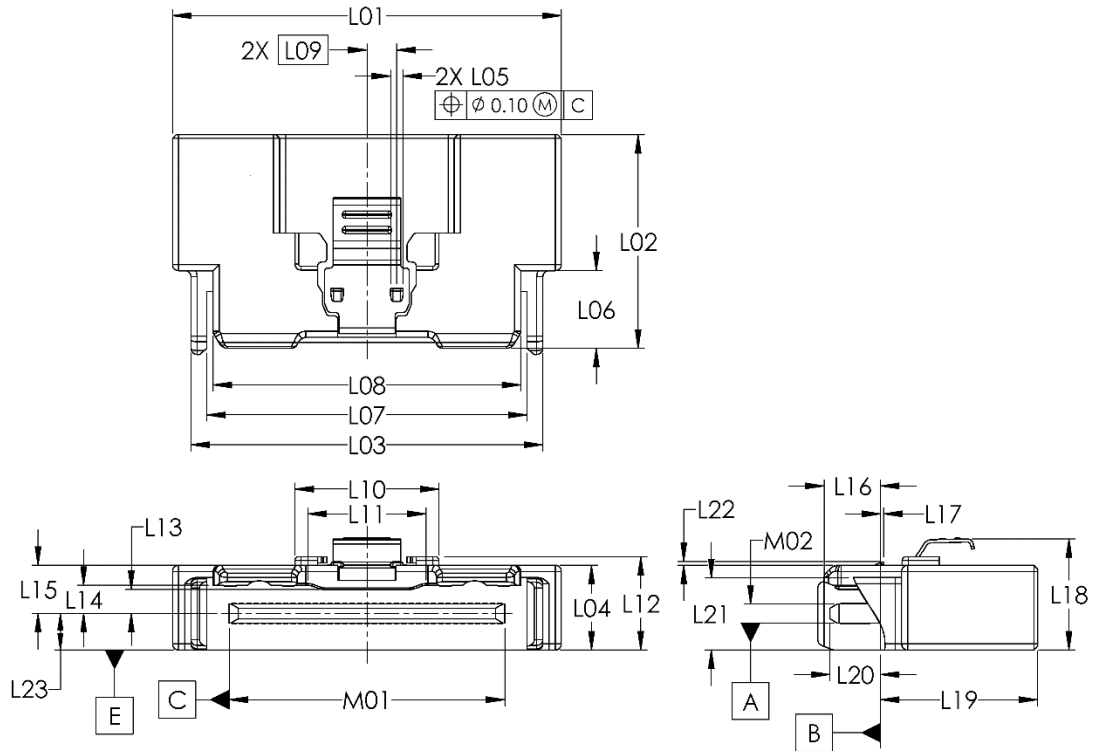

Figure 6-3 Straight Plug with Side Anti-skew Flanges for 74 Contacts

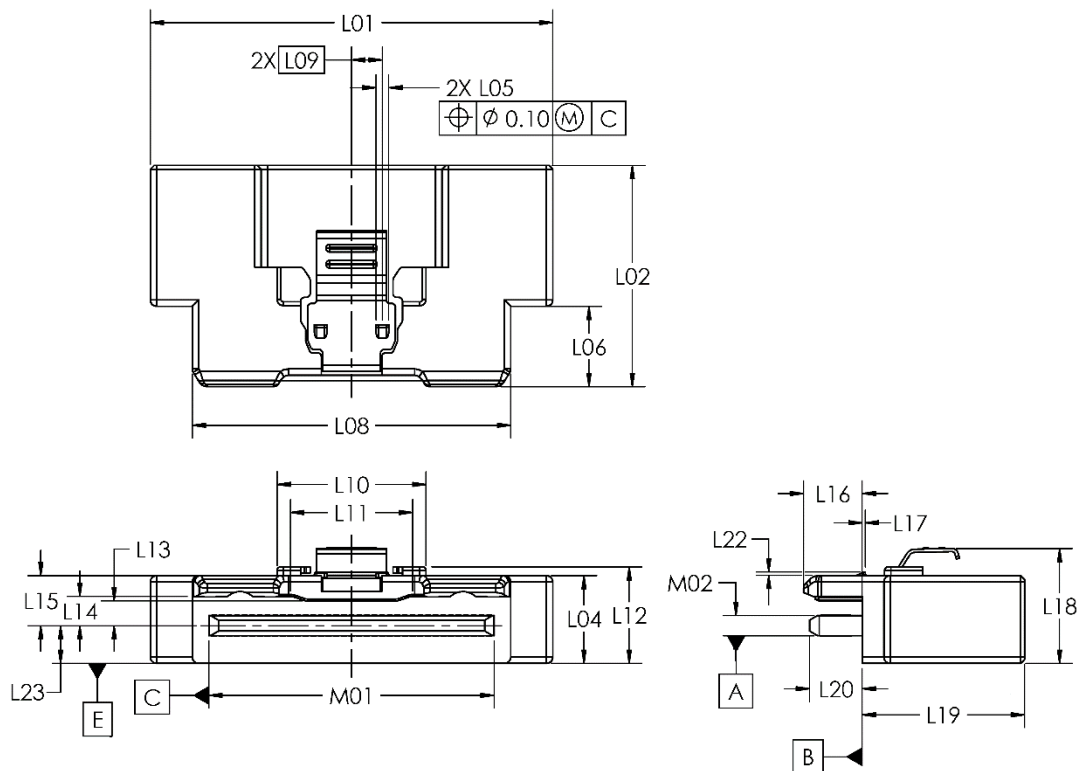

Figure 6-4 Straight Plug with No Side Flanges for 74 Contacts

Table 6-2 Dimensions for 74 Contact Plug Connectors

Designator	Description		Dimension (mm)	Tolerance +/-
M01	Interface Card Width		22.40	±0.05
M02	Paddle Card Thickness		1.57	±0.15
L01	Plug Body Rear Width (See Note 1)	with Side Anti-skew Flanges	31.60	MAX
		with No Side Anti-skew Flanges	25.95	±0.15
L02	Straight Plug Length		17.35	REF
L03	Plug Body Front Width (See Note 2)	with Side Anti-skew Flanges	28.60	±0.15
		with No Side Anti-skew Flanges	Equal to dimension L08	
L04	Plug Body Thickness		6.86	±0.10
L05	Latch Tab Width		1.00	±0.10
L06	Shroud Length		6.30	±0.10
L07	Anti-skew Flange Width (See Note 3)		26.10	+0.20/-0.10
L08	Shroud Width		25.12	MAX
L09	Datum C (Interface Centerline) to Latch Tab Center		2.42	Basic
L10	Latch Stopper Width		11.70	±0.20
L11	Bump of Shroud Width		9.59	MAX
L12	Datum E to Latch Stopper		7.58	REF
L13	Datum A to Bottom Surface of Shroud		1.87	MIN
L14	Datum A to Middle Surface of Shroud		2.32	MIN
L15	Datum A to Top Surface of Shroud		3.89	MAX
L16	Datum B to Edge of Shroud		4.60	±0.10
L17	Datum B to Back Edge of Latch Tab		0.24	+0.10/-0.20
L18	Datum E to Latch		9.00	REF
L19	Datum B to Plug Body End		12.75	REF
L20	Datum B to Card Edge		4.13	±0.13
L21	Datum E to Top Surface of Anti-skew Flange (See Note 3)		6.86	±0.10
L22	Top Surface of Shroud to Latch Tab Height	(When Free)	0.30	MIN
		(For Release)	0.05	MAX
L23	Datum A to Datum E		3.10	MAX

NOTES:

1. The narrow option allows for use in limited width applications, such as putting two connectors side-by-side along the short edge of a low-profile PCIe card. The narrow option does not include the side Anti-skew Flanges and the L01 dimension is reduced.
2. For the narrow option where the side Anti-skew Flange features are not included, this dimension equals dimension L08.
3. For the narrow option where the side Anti-skew Flange features are not included, these dimensions are not used.

6.2.3 Plug Connector with 124 Contacts

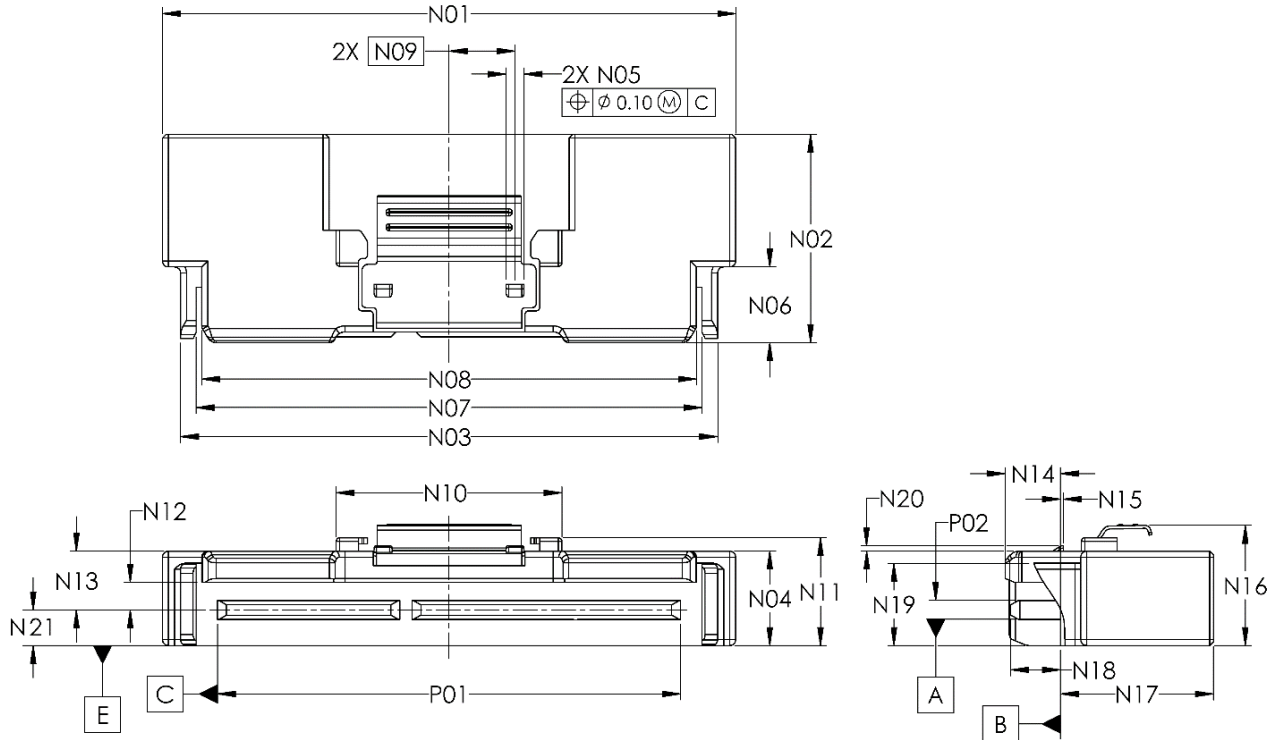

Figure 6-5 Straight Plug with Side Anti-skew Flanges for 124 Contacts

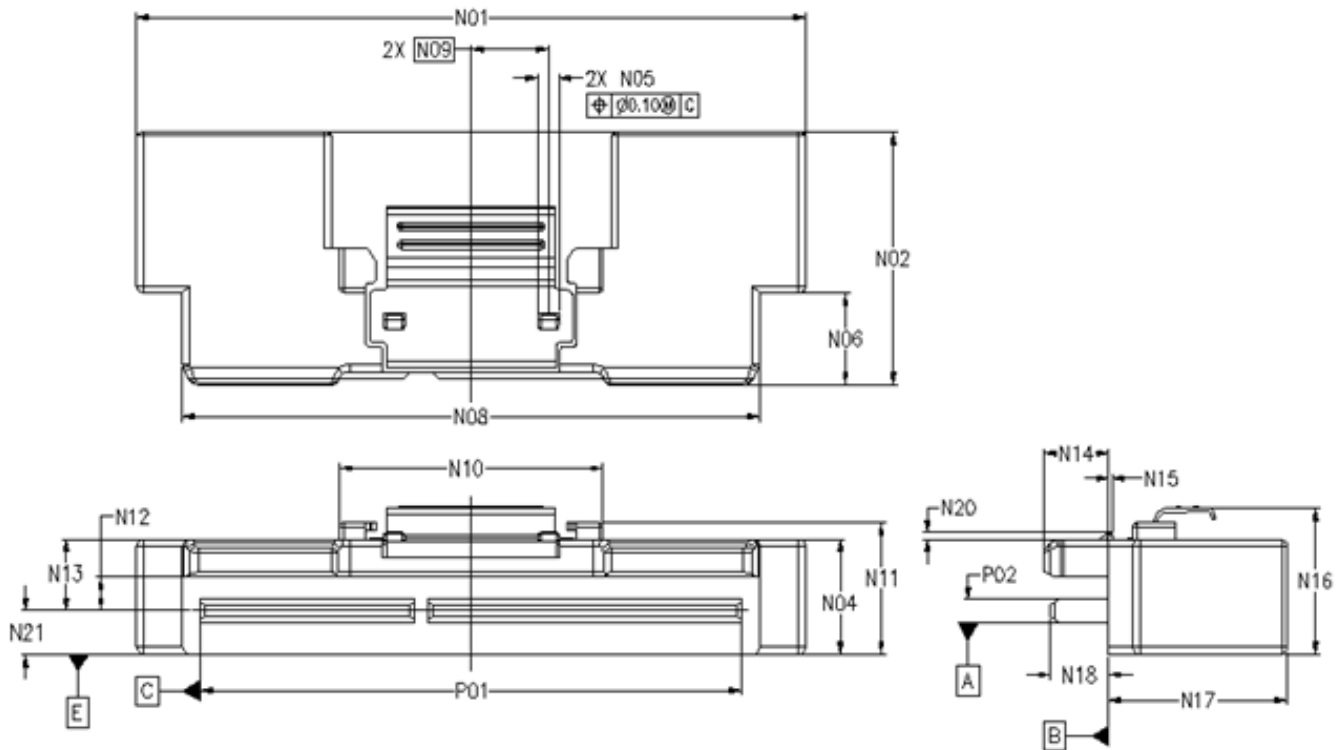

Figure 6-6 Straight Plug with No Side Flanges for 124 Contacts

Table 6-3 Dimensions for 124 Contact Plug Connectors

Designator	Description		Dimension (mm)	Tolerance +/-
P01	Interface Card Width		38.60	±0.05
P02	Paddle Card Thickness		1.57	±0.15
N01	Plug Body Rear Width (See Note 1)	with Side Anti-skew Flanges	47.80	MAX
		with No Side Anti-skew Flanges	42.15	±0.15
N02	Straight Plug Length		17.35	REF
N03	Plug Body Front Width (See Note 2)	with Side Anti-skew Flanges	44.80	±0.15
		with No Side Anti-skew Flanges	Equal to dimension N08	
N04	Plug Body Thickness		7.86	±0.10
N05	Latch Tab Width		1.50	±0.10
N06	Shroud Length		6.30	±0.10
N07	Anti-skew Flange Width (See Note 3)		42.30	+0.20/-0.10
N08	Shroud Width		41.32	MAX
N09	Datum C (Interface Centerline) to Latch Tab Center		5.50	Basic
N10	Latch Stopper Width		18.80	±0.20
N11	Datum E to Latch Stopper		8.98	REF
N12	Datum A to Middle Surface of Shroud		2.32	MIN
N13	Datum A to Top Surface of Shroud		4.89	MAX
N14	Datum B to Edge of Shroud		4.60	±0.10
N15	Datum B to Back Edge of Latch Tab		0.24	+0.10/-0.20
N16	Datum E to Latch		10.00	REF
N17	Datum B to Plug Body End		12.75	REF
N18	Datum B to Card Edge		4.13	±0.13
N19	Datum E to Top Surface of Anti-skew Flange (See Note 3)		7.86	±0.10
N20	Top Surface of Shroud to Latch Tab Height	(When Free)	0.30	MIN
		(For Release)	0.05	MAX
N21	Datum A to Datum E		3.10	MAX

NOTES:

1. The narrow option allows for use in limited width applications. The narrow option does not include the Side Anti-skew Flanges and the N01 dimension is reduced.
2. For the narrow option where the Side Anti-skew Flange features are not included, this dimension equals dimension N08.
3. For the narrow option where the Side Anti-skew Flange features are not included, these dimensions are not used.

6.2.4 Plug Connector with 148 Contacts

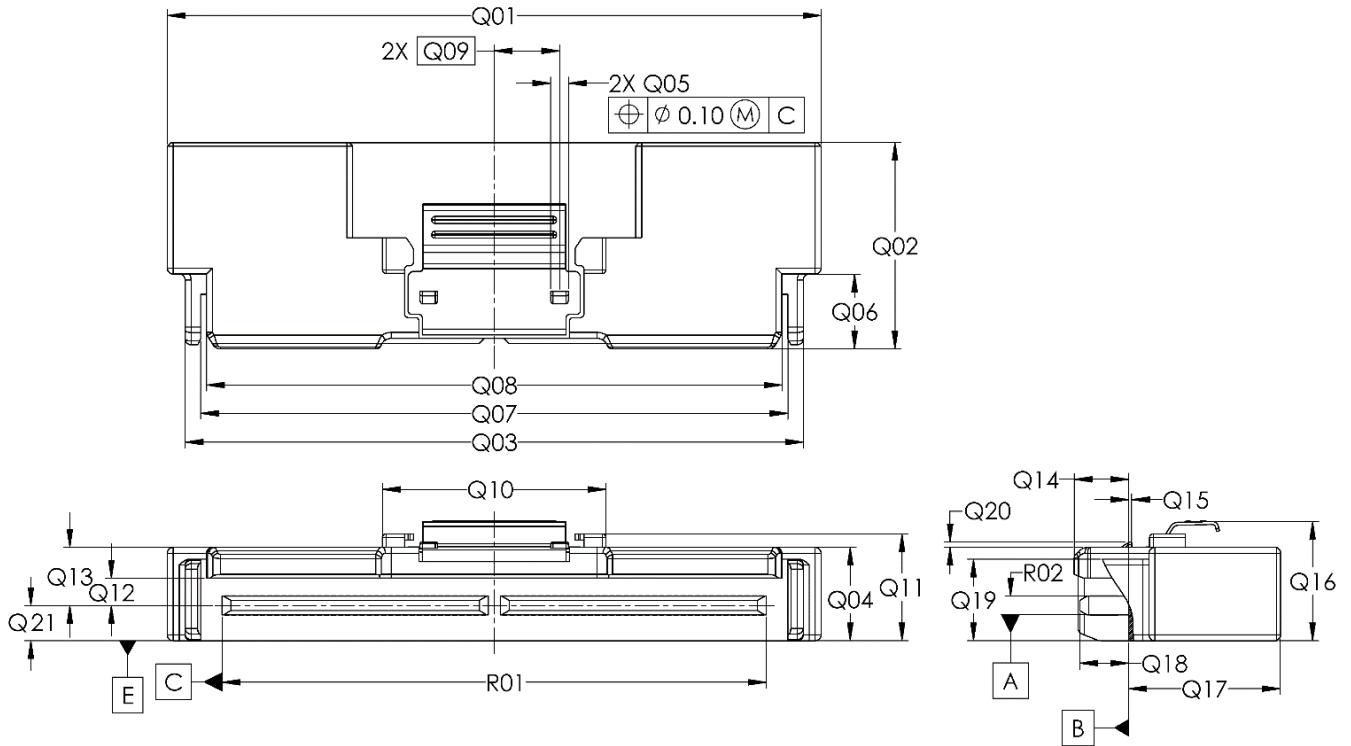

Figure 6-7 Straight Plug with Side Anti-skew Flanges for 148 Contacts

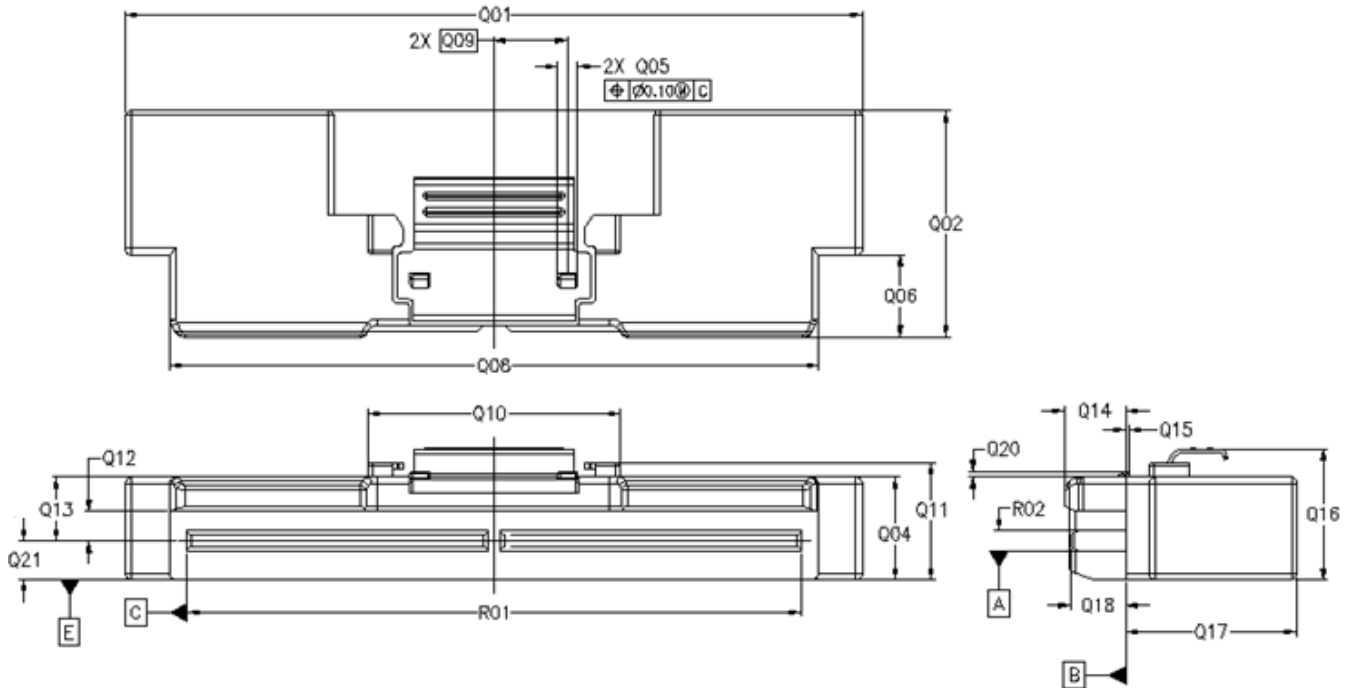

Figure 6-8 Straight Plug with No Side Flanges for 148 Contacts

Table 6-4 Dimensions for 148 Contact Plug Connectors

Designator	Description		Dimension (mm)	Tolerance +/-
R01	Interface Card Width		45.80	±0.05
R02	Paddle Card Thickness		1.57	±0.15
Q01	Plug Body Rear Width (See Note 1)	with Side Anti-skew Flanges	55.00	MAX
		with No Side Anti-skew Flanges	49.35	±0.15
Q02	Straight Plug Length		17.35	REF
Q03	Plug Body Front Width (See Note 2)	with Side Anti-skew Flanges	52.00	±0.15
		with No Side Anti-skew Flanges	Equal to dimension Q08	
Q04	Plug Body Thickness		7.86	±0.10
Q05	Latch Tab Width		1.50	±0.10
Q06	Shroud Length		6.30	±0.10
Q07	Anti-skew Flange Width (See Note 3)		49.50	+0.20/-0.10
Q08	Shroud Width		48.52	MAX
Q09	Datum C (Interface Centerline) to Latch Tab Center		5.50	Basic
Q10	Latch Stopper Width		18.80	±0.20
Q11	Datum E to Latch Stopper		8.98	REF
Q12	Datum A to Middle Surface of Shroud		2.32	MIN
Q13	Datum A to Top Surface of Shroud		4.89	MAX
Q14	Datum B to Edge of Shroud		4.60	±0.10
Q15	Datum B to Back Edge of Latch Tab		0.24	+0.10/-0.20
Q16	Datum E to Latch		10.00	REF
Q17	Datum B to Plug Body End		12.75	REF
Q18	Datum B to Card Edge		4.13	±0.13
Q19	Datum E to Top Surface of Anti-skew Flange (See Note 3)		7.86	±0.10
Q20	Top Surface of Shroud to Latch Tab Height	(When Free)	0.30	MIN
		(For Release)	0.05	MAX
Q21	Datum A to Datum E		3.10	MAX

NOTES:

1. The narrow option allows for use in limited width applications. The narrow option does not include the Side Anti-skew Flanges and the Q01 dimension is reduced.
2. For the narrow option where the Side Anti-skew Flange features are not included, this dimension equals dimension Q08.
3. For the narrow option where the Side Anti-skew Flange features are not included, these dimensions are not used.

6.2.5 Right Angle Plug Connector with 38/74/124/148 Contacts

The following figure shows dimensions that are specific to right angle plug connectors. For other detailed dimensions, refer back to the previous figures and tables within Section 6.2 associated with the appropriate size of straight plug connector.

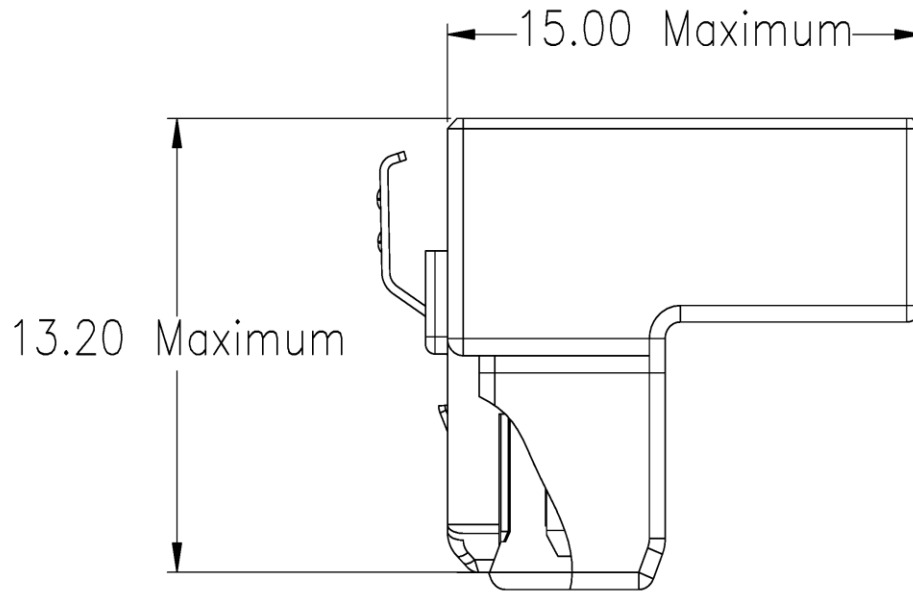

Figure 6-9 Right Angle Plug for 38/74/124/148 Contacts

6.3 Card Edge Description (Mechanical Interface)

The following figures and tables detail the mating interface pads and paddle card dimensions applicable to the mating interface of the plug connectors within this specification.

6.3.1 Plug Paddle Card with 38 Contacts

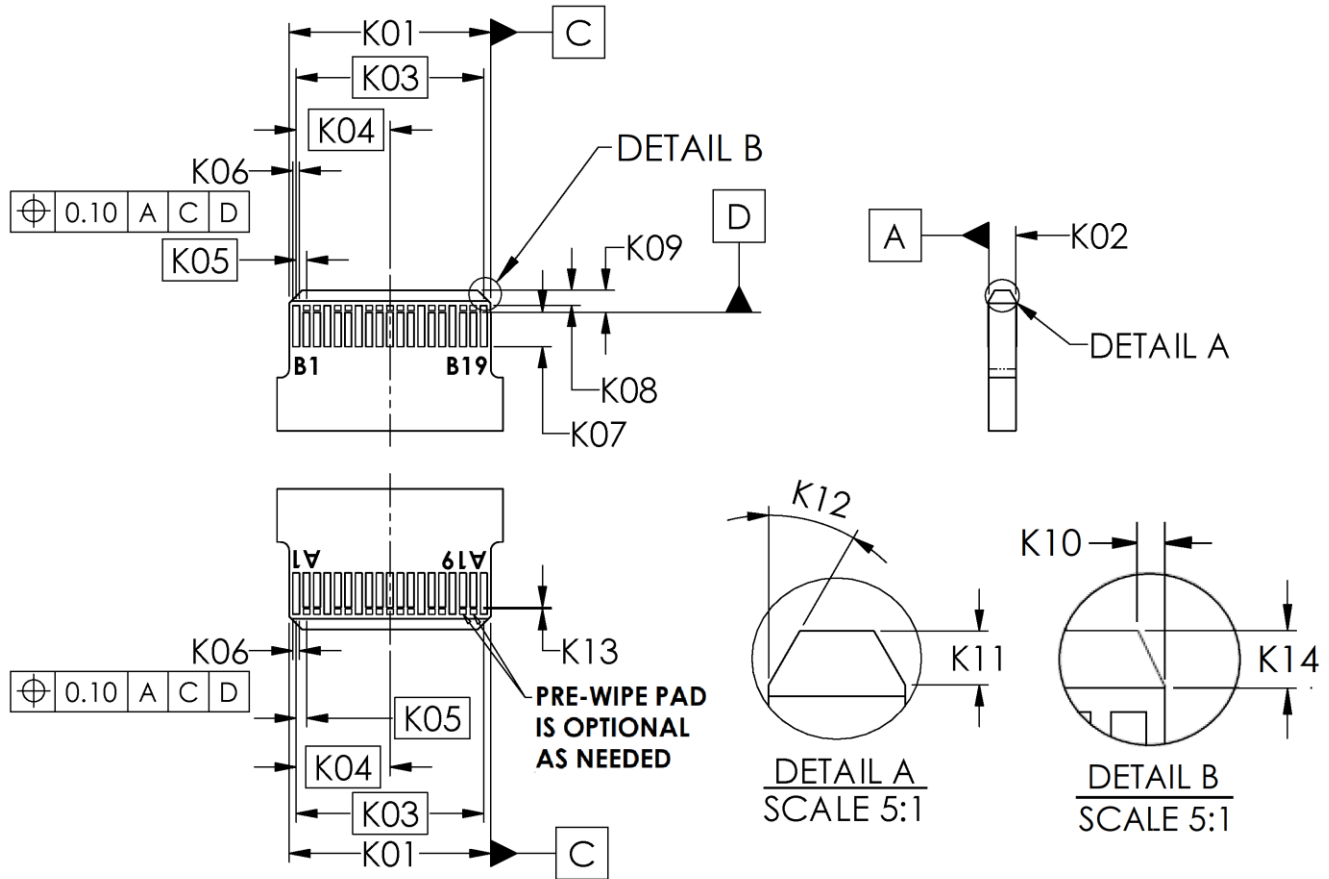

Figure 6-10 Plug Paddle Card for 38 Contacts

Table 6-5 Paddle Card Dimensions for Plug with 38 Contacts

Designator	Description	Dimension (mm)	Tolerance +/-
K01	Interface Card Width	11.60	±0.05
K02	Paddle Card Thickness	1.57	±0.15
K03	First Pad to Last Pad Centers	10.80	Basic
K04	Card Center to Outer Pad Center	5.40	Basic
K05	Pad Pitch (Center to Center)	0.60	Basic
K06	Pad Width	0.38	±0.03
K07	Pad Length – Second-mate	1.97	MIN
K08	First-mate Pad to Card Edge	0.88	±0.10
K09	Second-mate Pad to Card Edge	1.28	±0.10
K10	Corner Chamfer Width	0.30	±0.13
K11	Lead-in Angle Length	0.62	±0.13
K12	Lead-in Angle	30°	±5°
K13	Second Mate Pad to Pre-wipe Pad Gap	0.10	REF
K14	Corner Chamfer Length	0.62	±0.13

6.3.2 Plug Paddle Card with 74 Contacts

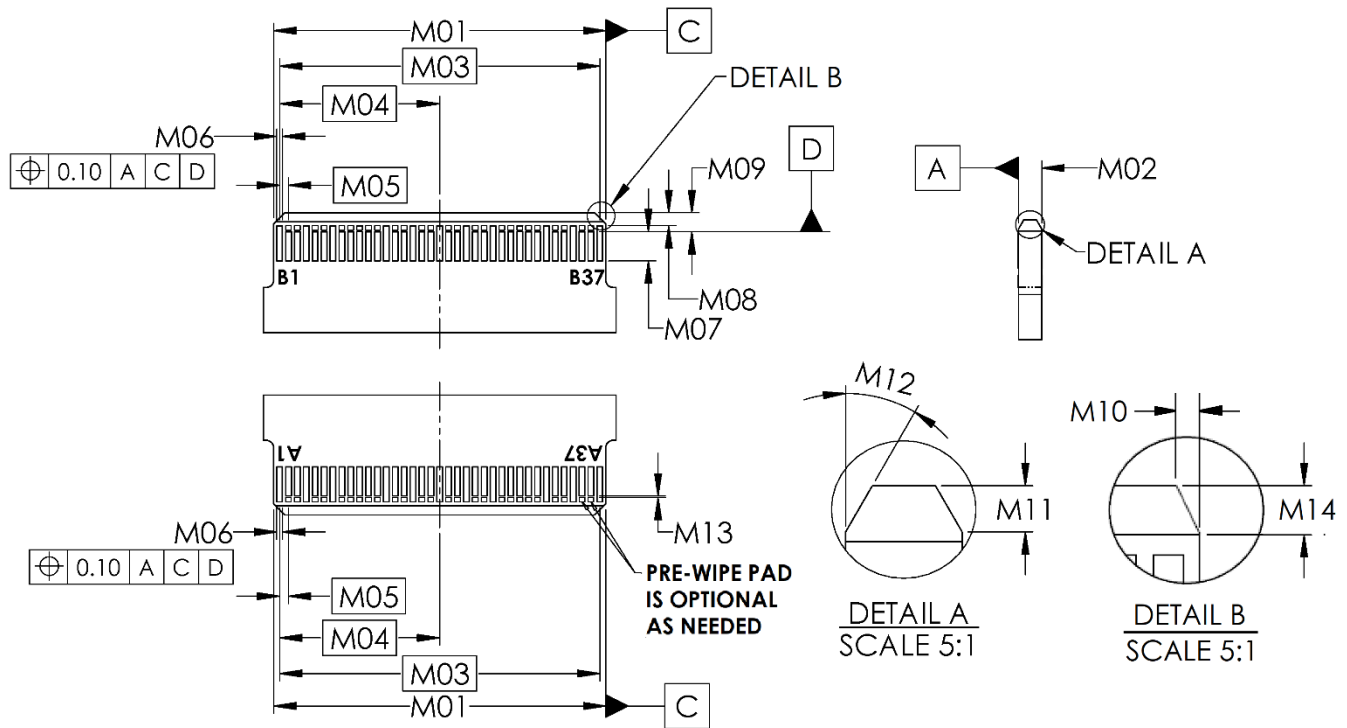

Figure 6-11 Plug Paddle Card for 74 Contacts

Table 6-6 Paddle Card Dimensions for Plug with 74 Contacts

Designator	Description	Dimension (mm)	Tolerance +/-
M01	Interface Card Width	22.40	±0.05
M02	Paddle Card Thickness	1.57	±0.15
M03	First Pad to Last Pad Centers	21.60	Basic
M04	Card Center to Outer Pad Center	10.80	Basic
M05	Pad Pitch (Center to Center)	0.60	Basic
M06	Pad Width	0.38	±0.03
M07	Pad Length – Second-mate	1.97	MIN
M08	First-mate Pad to Card Edge	0.88	±0.10
M09	Second-mate Pad to Card Edge	1.28	±0.10
M10	Corner Chamfer Width	0.30	±0.13
M11	Lead-in Angle Length	0.62	±0.13
M12	Lead-in Angle	30°	±5°
M13	Second-mate Pad to Pre-wipe Pad Gap	0.10	REF
M14	Corner Chamfer Length	0.62	±0.13

6.3.3 Plug Paddle Card with 124 Contacts

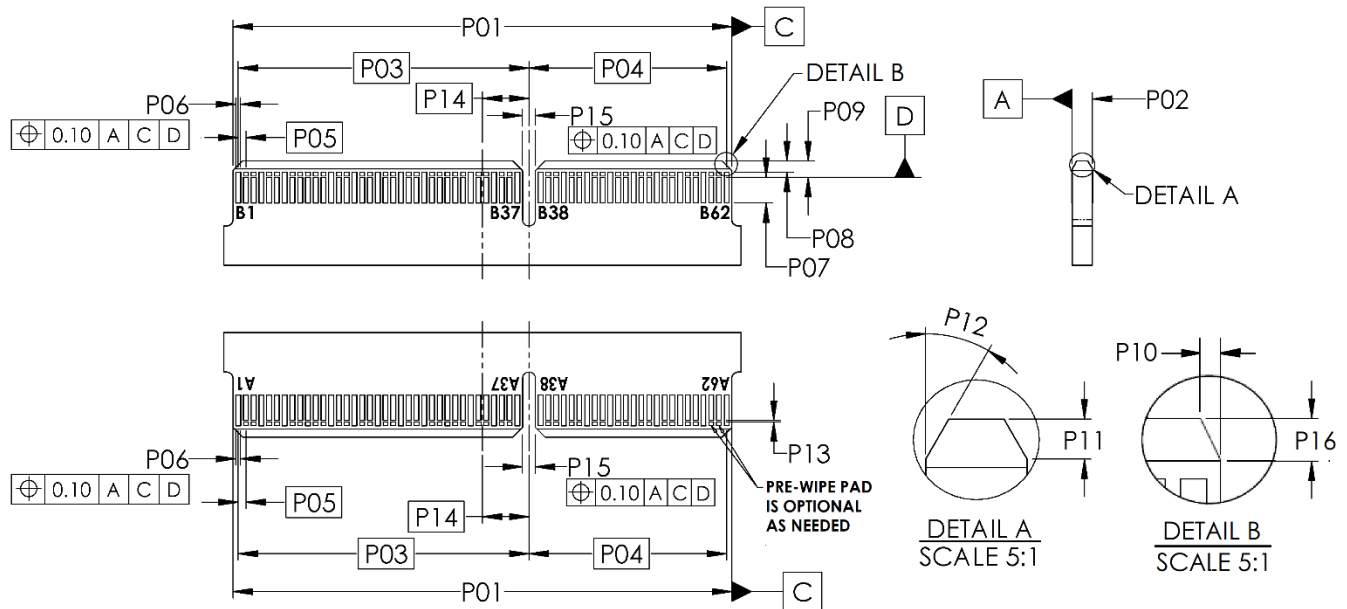

Figure 6-12 Plug Paddle Card for 124 Contacts

Table 6-7 Paddle Card Dimensions for Plug with 124 Contacts

Designator	Description	Dimension (mm)	Tolerance +/-
P01	Interface Card Width	38.60	±0.05
P02	Paddle Card Thickness	1.57	±0.15
P03	Key Slot Center to First Pad Center	22.50	Basic
P04	Key Slot Center to Last Pad Center	15.30	Basic
P05	Pad Pitch (Center to Center)	0.60	Basic
P06	Pad Width	0.38	±0.03
P07	Pad Length – Second-mate	1.97	MIN
P08	First-mate Pad to Card Edge	0.88	±0.10
P09	Second-mate Pad to Card Edge	1.28	±0.10
P10	Corner Chamfer Width	0.30	±0.13
P11	Lead-in Angle Length	0.62	±0.13
P12	Lead-in Angle	30°	±5°
P13	Second-mate Pad to Pre-wipe Pad Gap	0.10	REF
P14	Key Slot to Datum C (Paddle Card Centerline)	3.60	Basic
P15	Key Slot Width	1.00	±0.05
P16	Corner Chamfer Length	0.62	±0.13

6.3.4 Plug Paddle Card with 148 Contacts

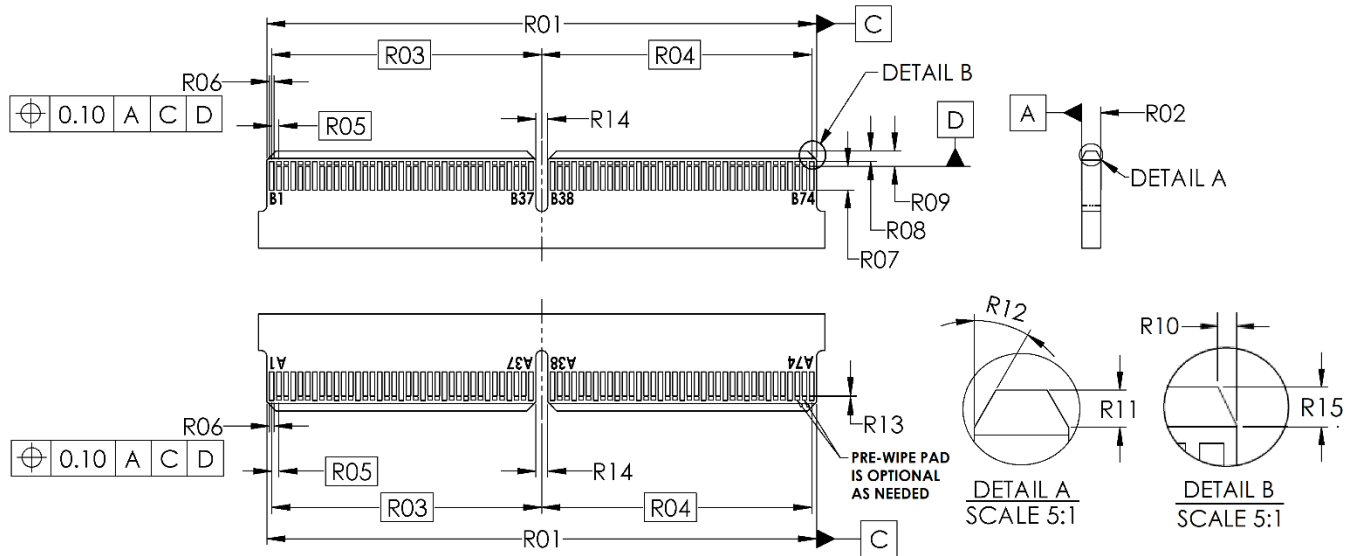

Figure 6-13 Plug Paddle Card for 148 Contacts

Table 6-8 Paddle Card Dimensions for Plug with 148 Contacts

Designator	Description	Dimension (mm)	Tolerance +/-
R01	Interface Card Width	45.80	±0.05
R02	Paddle Card Thickness	1.57	±0.15
R03	Key Slot Center to First Pad Center	22.50	Basic
R04	Key Slot Center to Last Pad Center	22.50	Basic
R05	Pad Pitch (Center to Center)	0.60	Basic
R06	Pad Width	0.38	±0.03
R07	Pad Length – Second-mate	1.97	MIN
R08	First-mate Pad to Card Edge	0.88	±0.10
R09	Second Mate Pad to Card Edge	1.28	±0.10
R10	Corner Chamfer Width	0.30	±0.13
R11	Lead-in Angle Length	0.62	±0.13
R12	Lead-in Angle	30°	±5°
R13	Second-mate Pad to Pre-wipe Pad Gap	0.10	REF
R14	Key Slot Width	1.00	±0.05
R15	Corner Chamfer Length	0.62	±0.13

7. Hybrid EDSFF Solution Mechanical Specification

7.1 Hybrid EDSFF Solution Overview

Certain applications may require a compact hybrid plug configuration, where the plug has a mating interface with 38 contacts and a side exit of the plug that incorporates an SFF-TA-1002 style EDSFF receptacle connector and may or may not include another side exit for cable wires.

The details about the pinouts used for these hybrid plugs and the mating receptacle can be customer-specific. However, the general intent is for the high-speed lanes to pass from the EDSFF 1C or 2C receptacle at one side-exit of these hybrid plugs across to the wires at the other side-exit. These side-exit wires may lead to another SFF-TA-1016 plug as a cable assembly. There is intent for some sidebands (the sidebands are signals, power, and/or ground) to connect from the EDSFF 1C or 2C receptacle side-exit to the 38-contact card edge interface via the paddle card that is intended to plug into the mating hybrid standard vertical receptacle connector. Some sidebands may also connect from the wire side-exit to the 38-contact card edge interface via the paddle card, or to the EDSFF 1C or 2C receptacle side-exit, or may be connected to both.

The signal integrity requirements listed in Table 9-1 do not apply to the hybrid standard vertical receptacle connector. The hybrid standard vertical receptacle connector uses discrete contacts. No pin is tied together.

7.2 Mechanical Description: EDSFF E1 Hybrid Plugs

7.2.1 Hybrid Plug with 38 Contacts and E1 1C Connector

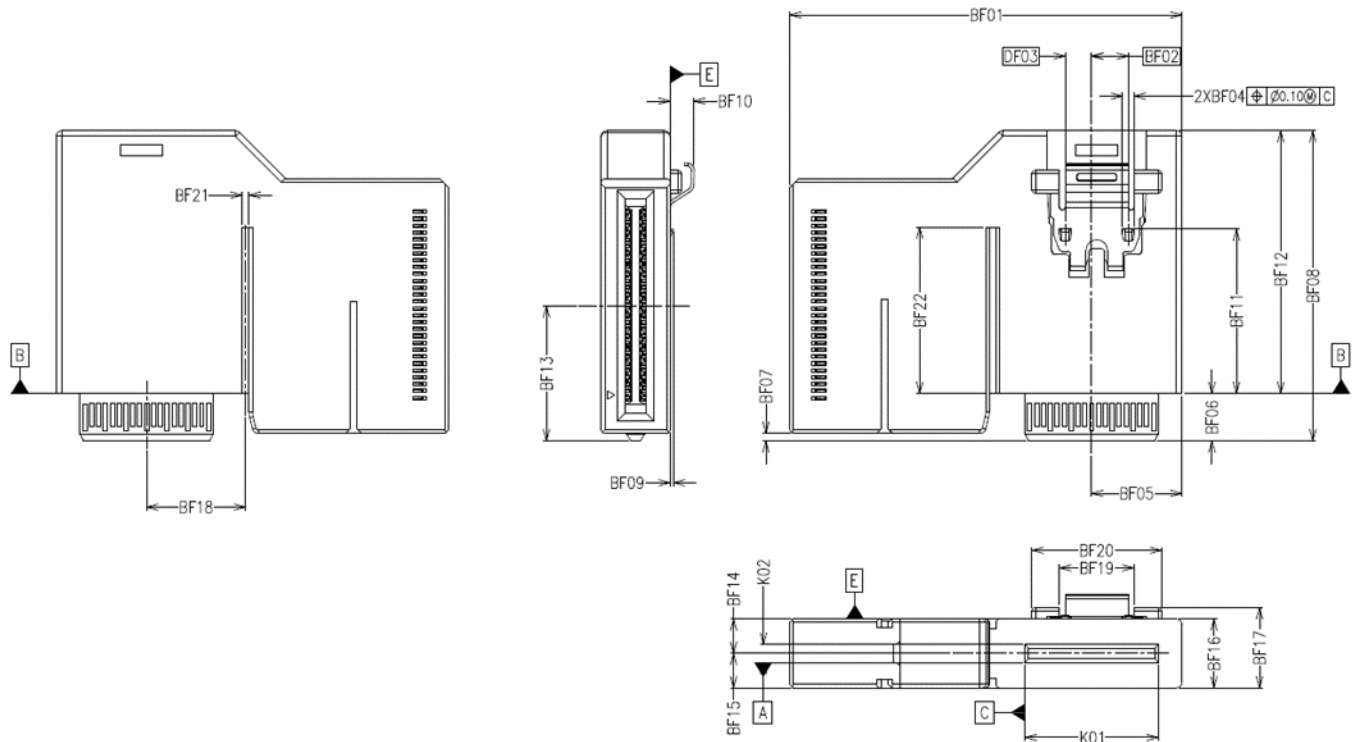

Figure 7-1 Hybrid Plug with 38 Contacts and E1 1C Connector

Table 7-1 Dimensions for Hybrid Plug with 38 Contacts and E1 1C Connector

Designator	Description	Dimension (mm)	Tolerance +/-	
BF01	Plug body top width	34.20	REF	
BF02	Datum C (interface centerline) to right latch tab center	3.20	Basic	
BF03	Datum C (interface centerline) to left latch tab center	2.30	Basic	
BF04	Latch tab width	1.00	±0.10	
BF05	Datum C (interface centerline) to plug body end	7.85	±0.10	
BF06	Datum B to paddle card edge	4.13	±0.13	
BF07	Paddle card edge to 1C connector bottom edge	0.65	±0.10	
BF08	Paddle card edge to plug body top	27.03	REF	
BF09	Top surface of shroud to latch tab height	(when free)	0.30	MIN
		(for release)	0.05	MAX
BF10	Datum E to latch	2.14	REF	
BF11	Datum E to latch tip	14.43	+0.10/-0.20	
BF12	Datum B to plug body top	22.90	REF	
BF13	Paddle card edge to center of 1C connector	11.76	±0.10	
BF14	Datum A to Datum E (top surface plug body)	3.00	MAX	
BF15	Datum A to bottom surface plug body	3.00	MAX	
BF16	Plug body width	6.00	MAX	
BF17	Bottom surface plug body to latch stopper	7.00	REF	
BF18	Datum C to 1C connector leading slot	8.63	±0.10	
BF19	Latch stopper inner width	6.50	REF	
BF20	Latch stopper outer width	11.30	REF	
BF21	Leading slot width	0.60	±0.05	
BF22	Leading slot length	14.50	REF	
K01	Interface card width	11.60	±0.05	
K02	Paddle card thickness	1.57	±0.15	

Table 7-2 Dimensions for Hybrid Plug with 38 Contacts and E1 2C Connector

Designator	Description	Dimension (mm)	Tolerance +/-	
BG01	Plug body top width	34.20	REF	
BG02	Datum C (interface centerline) to right latch tab center	3.20	Basic	
BG03	Datum C (interface centerline) to left latch tab center	2.30	Basic	
BG04	Latch tab width	1.00	±0.10	
BG05	Datum C (interface centerline) to plug body end	7.85	±0.10	
BG06	Datum B to paddle card edge	4.13	±0.13	
BG07	Paddle card edge to 1C connector bottom edge	1.86	±0.10	
BG08	Paddle card edge to plug body top	32.04	REF	
BG09	Top surface of shroud to latch tab height	(when free)	0.30	MIN
		(for release)	0.05	MAX
BG10	Datum E to latch	2.14	REF	
BG11	Datum E to latch tip	14.43	+0.10/-0.20	
BG12	Datum B to plug body top	27.92	REF	
BG13	Paddle card edge to center of 1C connector	9.27	±0.10	
BG14	Datum A to Datum E (top surface plug body)	3.00	MAX	
BG15	Datum A to bottom surface plug body	3.00	MAX	
BG16	Plug body width	6.00	MAX	
BG17	Bottom surface plug body to latch stopper	8.00	REF	
BG18	Datum C to 1C connector leading slot	8.63	±0.10	
BG19	Latch stopper inner width	6.50	REF	
BG20	Latch stopper outer width	11.30	REF	
BG21	Leading slot width	0.60	±0.05	
BG22	Leading slot length	14.50	REF	
K01	Interface card width	11.60	±0.05	
K02	Paddle card thickness	1.57	±0.15	

7.3 Mechanical Description: EDSFF E3 Hybrid Plugs

7.3.1 Hybrid Plug with 38 Contacts and E3 1C Connector

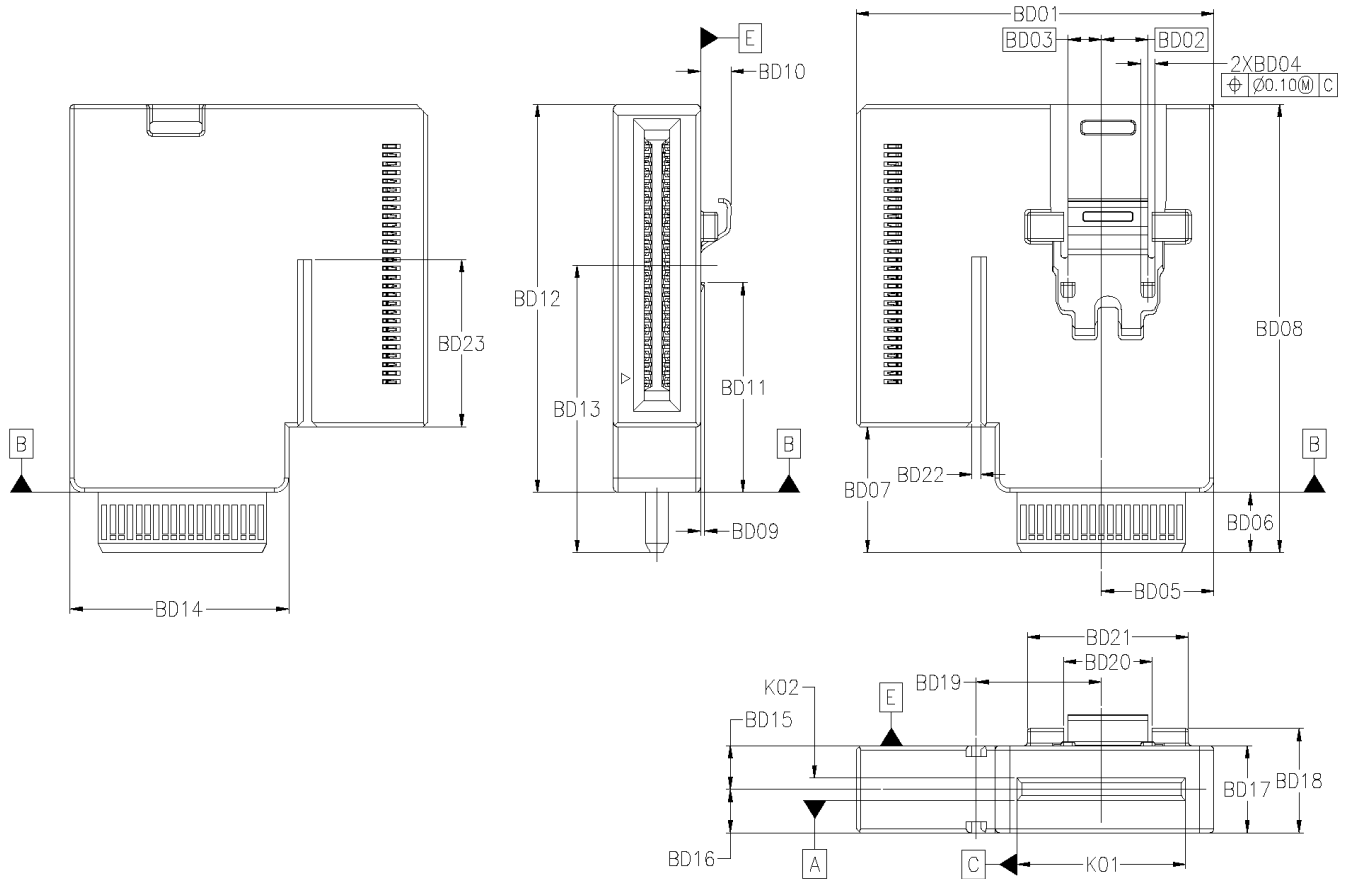

Figure 7-3 Hybrid Plug with 38 Contacts and E3 1C Connector

Table 7-3 Dimensions for Hybrid Plug with 38 Contacts and E3 1C Connector

Designator	Description	Dimension (mm)	Tolerance +/-	
BD01	Plug body top width	24.65	REF	
BD02	Datum C (interface centerline) to right latch tab center	3.20	Basic	
BD03	Datum C (interface centerline) to left latch tab center	2.31	Basic	
BD04	Latch tab width	1.00	±0.10	
BD05	Datum C (interface centerline) to plug body end	7.75	±0.10	
BD06	Datum B to paddle card edge	4.13	±0.13	
BD07	Paddle card edge to 1C connector bottom edge	8.63	±0.10	
BD08	Paddle card edge to plug body top	30.81	REF	
BD09	Top surface of shroud to latch tab height	(when free)	0.30	MIN
		(for release)	0.05	MAX
BD10	Datum E to latch	2.14	REF	
BD11	Datum E to latch tip	14.43	+0.10/-0.20	
BD12	Datum B to plug body top	26.68	REF	
BD13	Paddle card edge to center of 1C connector	19.74	±0.10	
BD14	Plug body bottom width	15.08	REF	
BD15	Datum A to Datum E (top surface plug body)	3.00	MAX	
BD16	Datum A to bottom surface plug body	3.00	MAX	
BD17	Plug body width	6.00	MAX	
BD18	Bottom surface plug body to latch stopper	7.18	REF	
BD19	Datum C to 1C connector leading slot	8.63	±0.10	
BD20	Latch stopper inner width	6.50	REF	
BD21	Latch stopper outer width	11.30	REF	
BD22	Leading slot width	0.60	±0.05	
BD23	Leading slot length	11.50	REF	
K01	Interface card width	11.60	±0.05	
K02	Paddle card thickness	1.57	±0.15	

7.3.2 Hybrid Plug with 38 Contacts and E3 2C Connector

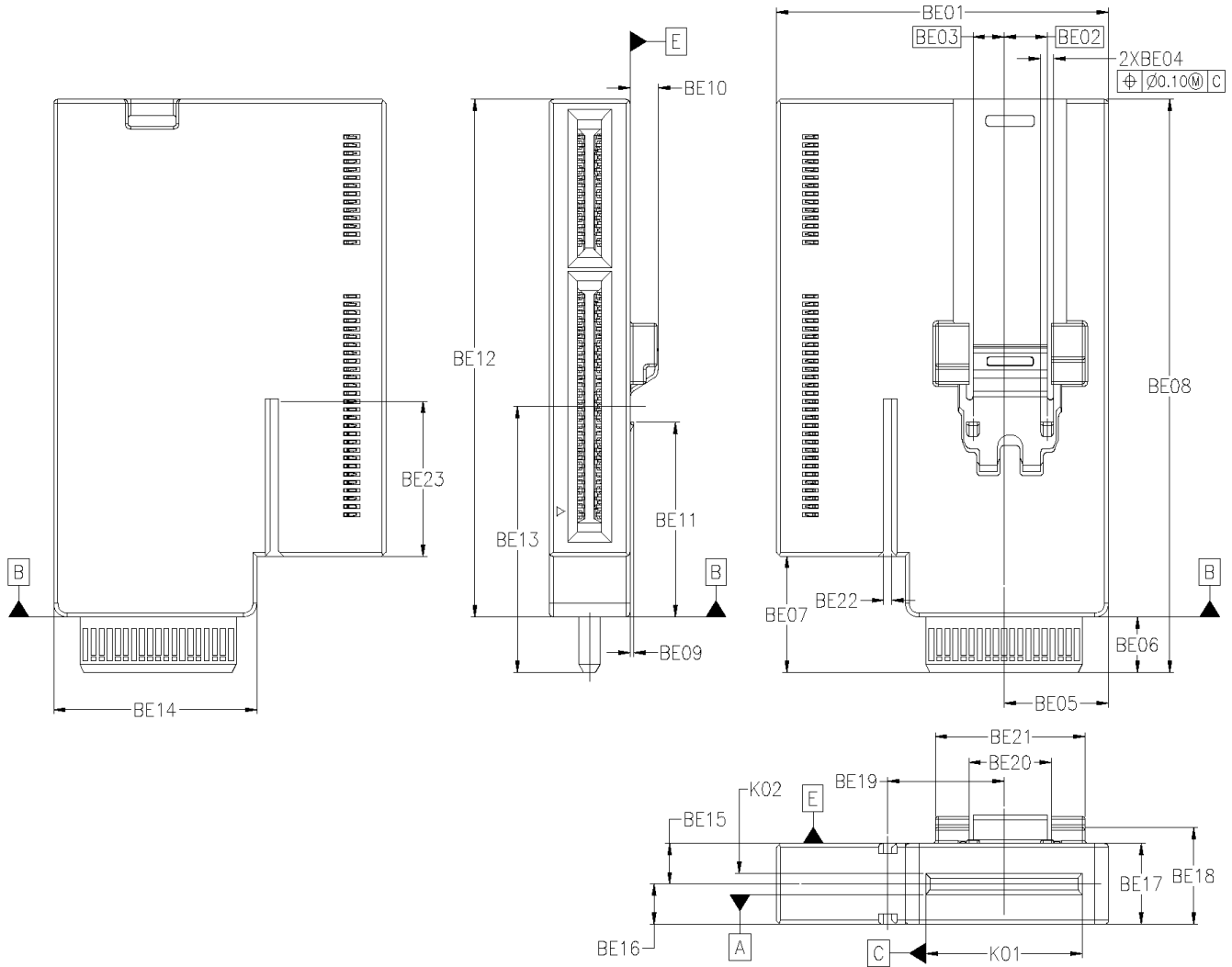

Figure 7-4 Hybrid Plug with 38 Contacts and E3 2C Connector

Table 7-4 Dimensions for Hybrid Plug with 38 Contacts and E3 2C Connector

Designator	Description	Dimension (mm)	Tolerance +/-	
BE01	Plug body top width	24.65	REF	
BE02	Datum C (interface centerline) to right latch tab center	3.20	Basic	
BE03	Datum C (interface centerline) to left latch tab center	2.31	Basic	
BE04	Latch tab width	1.00	±0.10	
BE05	Datum C (interface centerline) to plug body end	7.75	±0.10	
BE06	Datum B to paddle card edge	4.13	±0.13	
BE07	Paddle card edge to 1C connector bottom edge	8.63	±0.10	
BE08	Paddle card edge to plug body top	42.53	REF	
BE09	Top surface of shroud to latch tab height	(when free)	0.30	MIN
		(for release)	0.05	MAX
BE10	Datum E to latch	2.14	REF	
BE11	Datum E to latch tip	14.43	+0.10/-0.20	
BE12	Datum B to plug body top	38.40	REF	
BE13	Paddle card edge to center of 1C connector	19.74	±0.10	
BE14	Plug body bottom width	15.08	REF	
BE15	Datum A to Datum E (top surface plug body)	3.00	MAX	
BE16	Datum A to bottom surface plug body	3.00	MAX	
BE17	Plug body width	6.00	MAX	
BE18	Bottom surface plug body to latch stopper	7.18	REF	
BE19	Datum C to 1C Conn Leading Slot	8.63	±0.10	
BE20	Latch stopper inner width	6.50	REF	
BE21	Latch stopper outer width	11.30	REF	
BE22	Leading slot width	0.60	±0.05	
BE23	Leading slot length	11.50	REF	
K01	Interface card width	11.60	±0.05	
K02	Paddle card thickness	1.57	±0.15	

7.4 Hybrid Standard Vertical Receptacle Connector with 38 Contacts

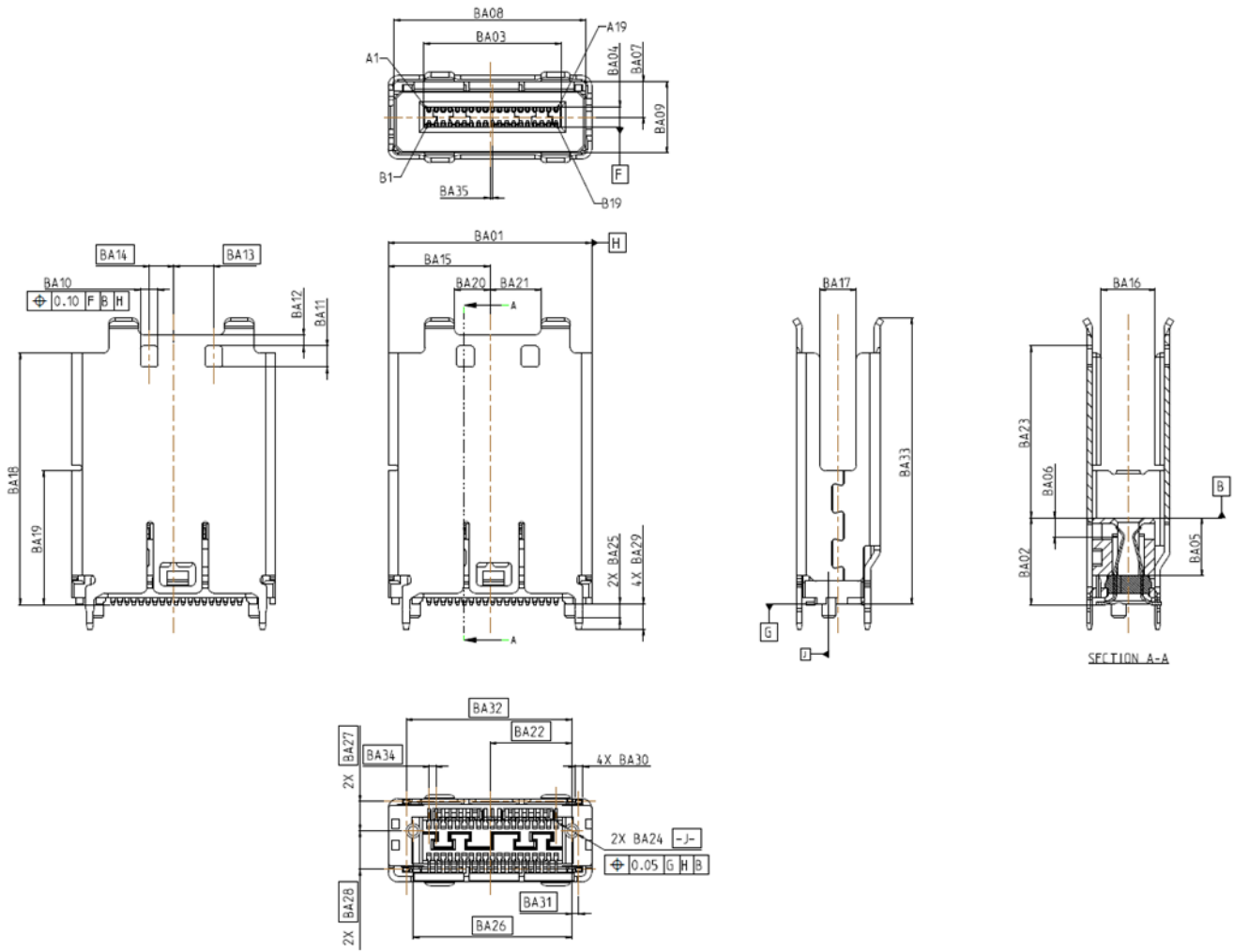

Figure 7-5 Hybrid Standard Vertical Receptacle Connector with 38 Contacts

Table 7-5 Dimensions for Hybrid Standard Vertical Receptacle Connector with 38 Contacts

Designator	Description	Dimension (mm)	Tolerance +/-
BA01	Receptacle width	17.33	MAX
BA02	Datum B (mating face) to PCB	7.40	±0.20
BA03	Card slot width	11.68	±0.03
BA04	Card slot height	1.80	MAX
BA05	Card slot depth	4.95	MIN
BA06	Datum B (mating face) to contact centerline	1.65	±0.10
BA07	Latch shroud inner height	3.05	±0.08
BA08	Latch shroud inner width	16.33	±0.08
BA09	Latch shroud extension width	6.10	±0.5
BA10	Latch slot width	1.50	±0.10
BA11	Latch slot length	1.80	+0.10/-0.00
BA12	Latch slot to edge	0.95	±0.05
BA13	Datum H (center of connector width) to right latch window center	3.41	Basic
BA14	Datum H (center of connector width) to left latch window center	2.09	Basic
BA15	Datum H (center of connector width) to front leading edge	8.66	±0.05
BA16	Front leading width	4.60	±0.05
BA17	Back leading width	3.10	±0.05
BA18	Front leading height	21.43	ref
BA19	Front and back shroud height	11.40	ref
BA20	Datum H (center of connector width) to left	3.02	±0.05
BA21	Datum H (center of connector width) to right	4.34	±0.05
BA22	Datum J (peg) to Datum H (center of connector width)	6.965	Basic
BA23	Datum B (mating face) to latch slot	14.63	±0.10
BA24	Peg diameter	1.20	±0.03
BA25	Peg length	1.20	REF
BA26	Datum J (peg) to peg	13.50	Basic
BA27	Datum J (peg) to first latch shroud solder pin	2.500	Basic
BA28	Datum J (peg) to first second shroud solder pin	3.29	Basic
BA29	Latch shroud solder pin height	2.20	REF
BA30	Latch shroud solder pin width	0.70	±0.05
BA31	Latch shroud solder pin to Datum J (peg)	0.600	Basic
BA32	Latch shroud solder pin to Datum J (peg)	14.100	Basic
BA33	Connector height	24.41	±0.3
BA34	Contact pitch	0.60	Basic
BA35	Centerline of slot to Datum H (centerline of connector width)	0.215	+/-0.05

8. Test Requirements and Methodologies (TS-1000, etc.)

8.1 Performance Tables

EIA-364-1000 (TS-1000) shall be used to define the test sequences and procedures for evaluating the connector system described in this document. Where multiple test options are available, the manufacturer shall select the appropriate option where not previously specified. The selected procedure should be noted when reporting data. If there are conflicting requirements or test procedures between EIA-364 procedures and those contained within this document, this document shall be considered the prevailing authority.

Unless otherwise specified, procedures for sample size, data, and collection to be followed as specified in EIA-364-1000. See EIA-364-1000 Annex B for objectives of tests and test groups.

Table 8-1 summarizes the performance criteria that are to be satisfied by the connector described in this document. Most performance criteria are validated by EIA-364-1000 testing, but this test suite leaves some test details to be determined. To ensure that testing is repeatable, these details are identified in Table 8-2. Finally, testing procedures used to validate any performance criteria not included in EIA-364-1000 are provided in Table 8-3.

Table 8-1 Form Factor Performance Requirements

Performance Parameters	Description/ Details	Requirement
Mechanical/ Physical Requirements		
Plating Type	Plating type on connector contacts	Precious
Surface Treatment	Surface treatment on connector contacts	Non-lubricated
Wipe length	Designed distance a contact traverses over a mating contact surface during mating and resting at a final position	Greater than 0.127mm
Rated Durability Cycles	The expected number of durability cycles a component is expected to encounter over the course of its life	Connector: 200 cycles Module: 200 cycles
Latched Mating Force*	Amount of force needed to mate a module with a connector when latches are deactivated	1.1 N/contact pair + 10 N MAX
Latched Unmating Force*	Amount of forced needed to separate a module from a connector when latches are deactivated	0.1 N/contact pair MIN
Latch Retention*	Amount of force the latching mechanism can withstand	50 N MIN
Wrenching Strength*	Amount of force in various directions the product can withstand while mated	25 N MIN for each axis direction

Table 8-1 Form Factor Performance Requirements (Continued)

Performance Parameters	Description/ Details	Requirement
Environmental Requirements		
Field Life	The expected service life for a component	10 years
Field Temperature	The expected service temperature for a component	0°C to +65°C
Storage Temperature*	The expected storage temperature for a component when not in use	-20°C to +80°C
Storage Humidity*	The expected storage humidity for a component when not in use	80% Relative Humidity
Electrical Requirements		
Current*	Maximum current to which a contact is exposed in use	1.1A per contact MAX 1.1A per power contact MAX
Operating Rating Voltage	Maximum voltage to which a contact is exposed in use	30V DC per contact MAX
<p>NOTE: Performance criteria denoted with stars (*) are not validated by EIA-364-1000 testing. Refer to Table 8-3 for test procedures and pass/fail criteria.</p>		

Table 8-2 describes the details necessary to perform the tests described in the EIA-364-1000 test sequences. Testing shall be done in accordance with EIA-364-1000 and the test procedures it identifies in such a way that the parameters/ requirements defined in Table 8-1 are met. Any information in this table supersedes EIA-364-1000.

Table 8-2 EIA-364-1000 Test Details

Test	Test Descriptions and Details	Pass/ Fail Criteria
Mechanical/ Physical Tests		
Durability (preconditioning)	EIA-364-09 To be tested with connector and module (Latches should be locked out)	No evidence of physical damage
Durability (see Note 1)	EIA-364-09 To be tested with connector and module (Latches should be locked out per EIA-364-1000)	No visual damage to mating interface or latching mechanism
Environmental Tests		
Mixed Flowing Gas (see Note 2)	EIA-364-65 Class IIA Duration: 7 days Test option Per EIA-364-1000: 4	No intermediate test criteria
Electrical Tests		
Low Level Contact Resistance (see Note 3)	EIA-364-23 20 mV DC MAX, 100 mA MAX To include wire termination or connector-to-board termination	20 mΩ MAX change from baseline
Dielectric Withstanding Voltage	EIA-364-20 Method B 300 VDC minimum for 1 minute Applied voltage may be product / application specific	No defect or breakdown between adjacent contacts -AND- 0.5 mA Max Leakage Current
NOTES:		
<ol style="list-style-type: none"> 1. If the durability requirement on the connector is greater than that of the module, modules may be replaced after their specified durability rating. 2. Test option, temperature, duration must be reported. 3. The first low level contact resistance reading in each test sequence is used to determine a baseline measurement. Subsequent measurements in each sequence are measured against this baseline. 		

Table 8-3 describes the testing procedures necessary to validate performance criteria not validated by EIA-364-1000 testing. The tests are to be performed in such a way that the parameters/ requirements defined in Table 8-1 are met.

Table 8-3 Additional Test Procedures

Test (see Note 1)	Test Descriptions and Details	Pass/ Fail Criteria
Mechanical/ Physical Tests		
Latched Mating Force	EIA-364-13 To be tested with connector (with integrated latch shroud) and module (plug) without any heat sinks. Latching mechanism deactivated (locked out)	Refer to Table 8-1 -AND- No physical damage to any components
Latched Unmating Force	EIA-364-13 To be tested with connector (with integrated latch shroud) and module (plug) without any heat sinks. Latching mechanism deactivated (locked out)	
Latch Retention	EIA-364-13 To be tested with connector (with integrated latch shroud) and module (plug) without any heat sinks. Latching mechanism engaged (not locked out)	
Wrenching Strength	Bend cable 90° at minimum bend radius. Pull 25 N Min in each of 4 axis directions for round cable. Pull 25 N Min in each of 2 axis directions for flat cable.	No damage to plug / cable assembly.
Environmental Tests		
Storage Temperature	EIA-364-32 Method A, Test Condition 1, Duration 4 Use min and max Field Temperatures listed in Table 8-1 for temperature range	Refer to Table 8-1
Storage Humidity	EIA-364-31	Refer to Table 8-1
Electrical Tests		
Current	EIA-364-70 Method 3, 30-degree temperature rise Contacts energized: Up to a maximum of 6 adjacent contacts per side, 12 contacts total	Refer to Table 8-1 for current magnitude
<p>NOTES:</p> <p>1. Requirements and tests specified that fall outside of EIA-364-1000 testing are listed in this table.</p>		

9. Electrical Characteristics

9.1 Signal Integrity Requirements

The signal integrity (SI) requirements for a mated connector pair are listed in Table 9-1 for various line rates. Products meeting this specification shall meet the appropriate requirements listed for the applicable line rate. Testing of these requirements shall comply with specification SFF-TA-1024. Additional connector SI requirements and any cable assembly SI requirements are application specific and are out of the scope of this specification. Refer to the appropriate performance specifications required by the specific application (e.g. Ethernet, Fibre Channel, InfiniBand, PCIe, SAS, or some custom application).

Table 9-1 Mated Connector Signal Integrity Requirements

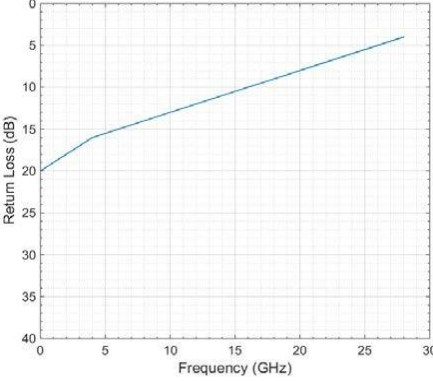
Line Rate	Insertion Loss	Return Loss	Power Sum Near End and Far End Crosstalk
25 GT/s NRZ	Up to 16GHz, Loss ≤ 1dB	From 0 to 4GHz, ≤ freq(GHz)-20 dB; From 4GHz to 28GHz, ≤ 0.5*freq(GHz)-18 dB 	Up to 16GHz, ≤ 40dB
28 GT/s NRZ	Up to 16GHz, Loss ≤ 1dB		Up to 16GHz, ≤ 40dB
56 GT/s PAM4	Up to 16GHz, Loss ≤ 1dB		Up to 16GHz, ≤ 40dB
32 GT/s NRZ	Up to 16GHz, Loss ≤ 1dB		Up to 16GHz, ≤ 40dB
56 GT/s NRZ	Up to 16GHz, Loss ≤ 1dB For frequency > 16GHz and ≤ 28GHz, Loss ≤ 1.5dB		Up to 16GHz, ≤ 40dB For frequency > 16GHz and ≤ 28GHz, ≤ 36dB
112 GT/s PAM4	Up to 16GHz, Loss ≤ 1dB For frequency > 16GHz and ≤ 28GHz, Loss ≤ 1.5dB		Up to 16GHz, ≤ 40dB For frequency > 16GHz and ≤ 28GHz, ≤ 36dB

Appendix A: System Mechanical Specification (Informative)

A.1 Overview

All material within this appendix, whether defined as normative or informative, is subject to IP disclosure and reasonable and non-discriminatory (RAND) terms by SNIA SFF TA TWG member companies.

A.2 PCB Layout

A.2.1 Recommended PCB layout for Right Angle 38P/74P Connector Footprints

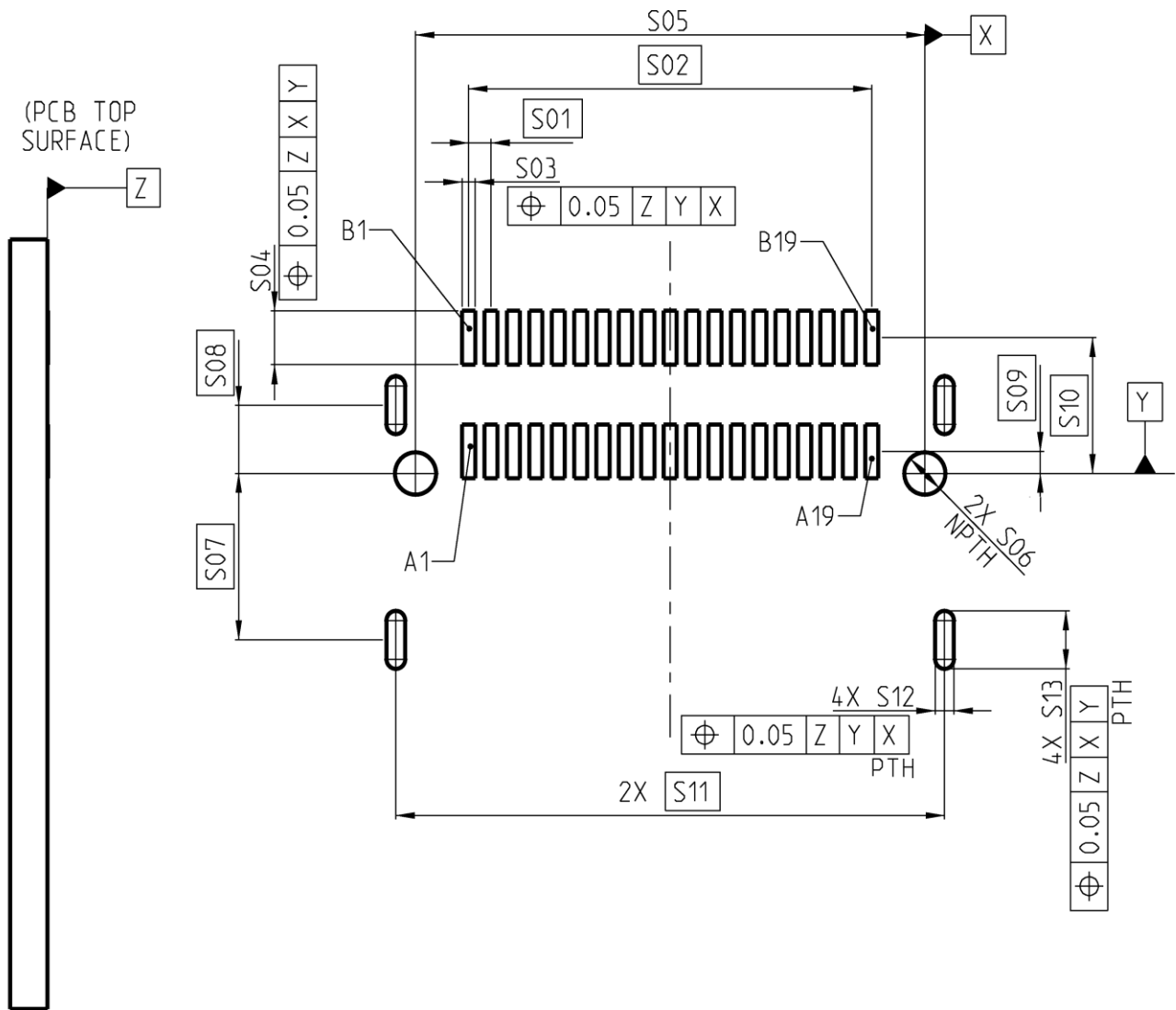

Figure A-1 Recommended Footprints for RA 38P/74P

Table A-1 Recommended Footprint Dimensions for RA 38P/74P

Designator	Description	Dimension (mm)	Tolerance +/-
S01	Pad Pitch	0.60	Basic
S02	First Pad to Last Pad Centers	10.80 (for 38P) 21.60 (for 74P)	Basic
S03	Pad Width	0.35	±0.03
S04	Pad Length	1.40	±0.03
S05	Locating Hole Spacing	13.645 (for 38P) 24.445 (for 74P)	±0.05
S06	Locating Hole Diameter	1.10	±0.05
S07	Datum Y to First Row of Solder Pin Hole Slots	4.325	Basic
S08	Datum Y to Second Row of Solder Pin Hole Slots	1.775	Basic
S09	Datum Y to Pad Row A Centerline	0.575	Basic
S10	Datum Y to Pad Row B Centerline	3.525	Basic
S11	Left Solder Pin Slots to Right Solder Pin Slots	14.70 (for 38P) 25.50 (for 74P)	Basic
S12	Solder Pin Hole Slot Width	0.60	±0.05
S13	Solder Pin Hole Slot Length	1.50	±0.05

A.2.2 Recommended PCB layout for Right Angle 124P/148P Connector Footprints

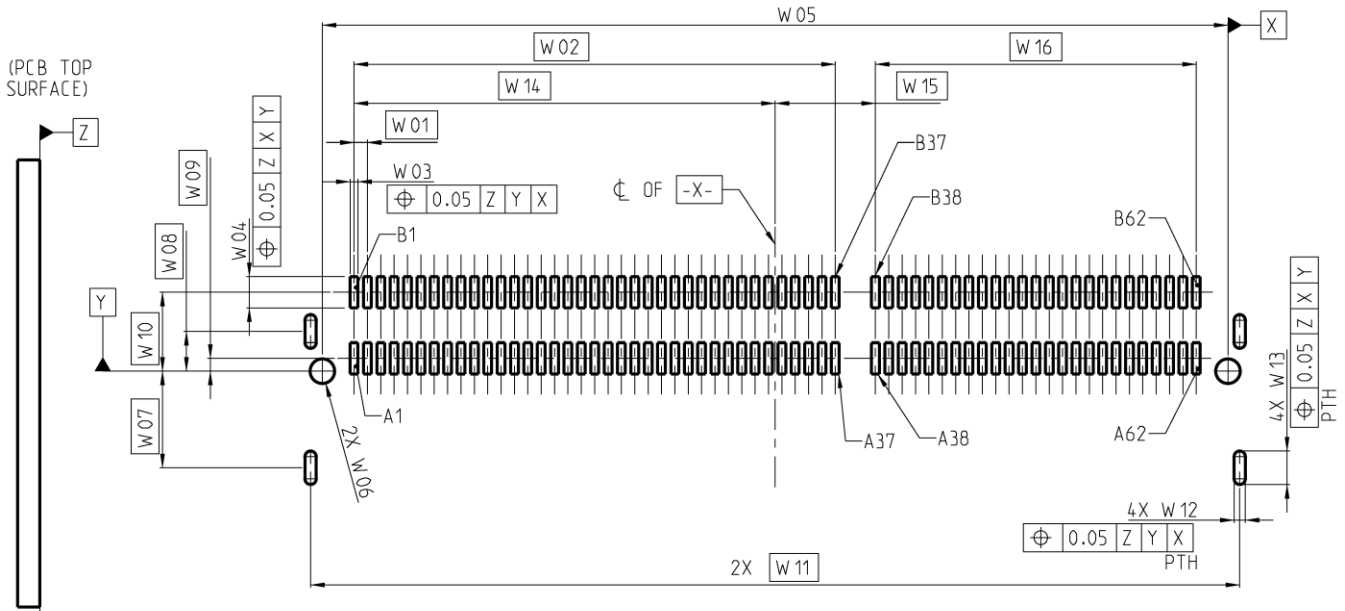

Figure A-2 Recommended Footprints for RA 124P/148P

Table A-2 Recommended Footprint Dimensions for RA 124P/148P

Designator	Description	Dimension (mm)	Tolerance +/-
W01	Pad Pitch	0.60	Basic
W02	First Pad to Last Pad Centers – Port 1	21.60	Basic
W03	Pad Width	0.35	±0.03
W04	Pad Length	1.40	±0.03
W05	Locating Hole Spacing	40.645 (for 124P) 47.845 (for 148P)	±0.05
W06	Locating Hole Diameter	1.10	±0.05
W07	Datum Y to First Row of Solder Pin Hole Slots	4.325	Basic
W08	Datum Y to Second Row of Solder Pin Hole Slots	1.775	Basic
W09	Datum Y to Pad Row A Centerline	0.575	Basic
W10	Datum Y to Pad Row B Centerline	3.525	Basic
W11	Left Solder Pin Slots to Right Solder Pin Slots	41.70 (for 124P) 48.90 (for 148P)	Basic
W12	Solder Pin Hole Slot Width	0.60	±0.05
W13	Solder Pin Hole Slot Length	1.50	±0.05
W14	Datum X to Pin A1/B1	18.90 (for 124P) 22.50 (for 148P)	Basic
W15	Datum X to Pin A38/B38	4.5 (for 124P) 0.9 (for 148P)	Basic
W16	First Pad to Last Pad Centers – Port 2	14.40 (for 124P) 21.60 (for 148P)	Basic

A.2.3 Recommended PCB layout for Vertical 38P/74P Connector Footprints

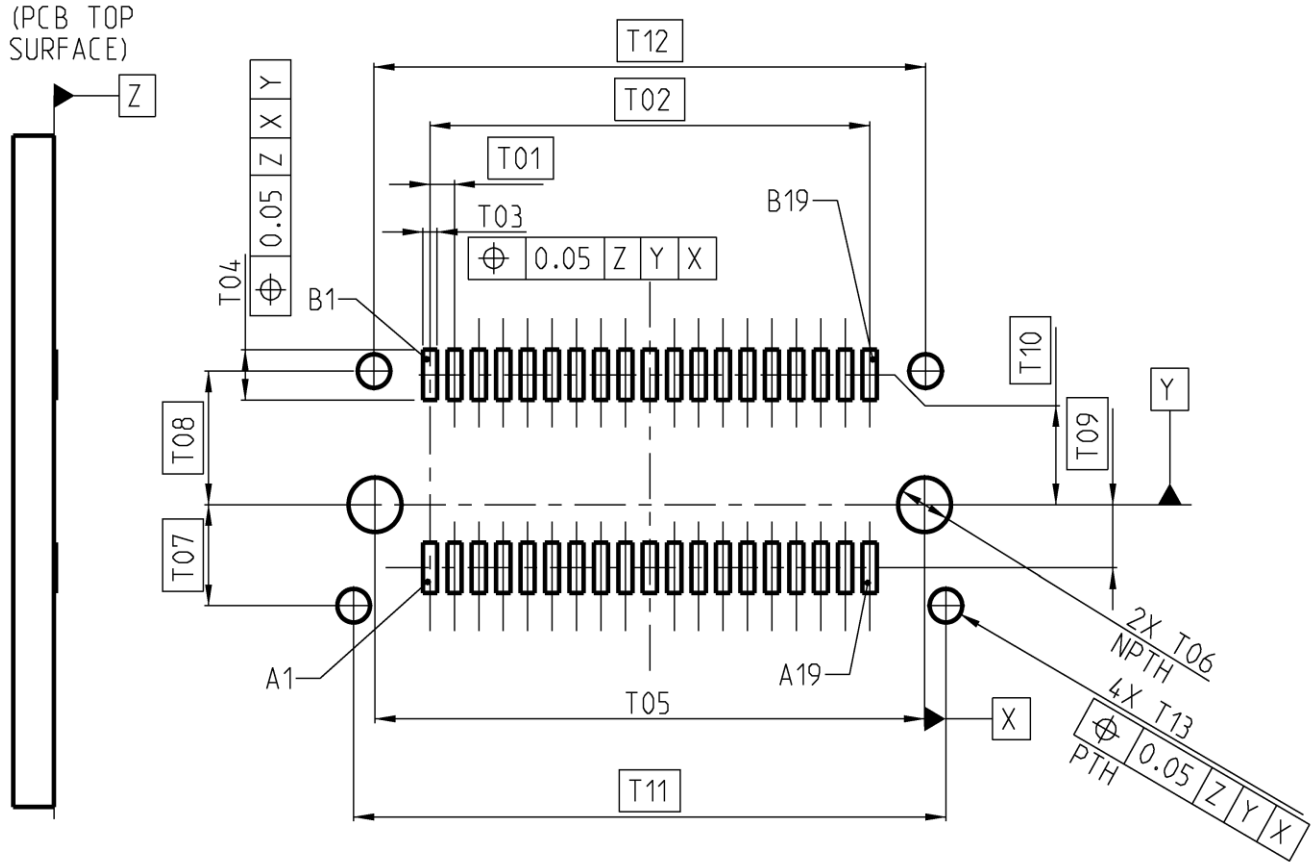

Figure A-3 Recommended Footprints for VT 38P/74P

Table A-3 Recommended Footprint Dimensions for VT 38P/74P

Designator	Description	Dimension (mm)	Tolerance +/-
T01	Pad Pitch	0.60	Basic
T02	First Pad to Last Pad Centers	10.80 (for 38P) 21.60 (for 74P)	Basic
T03	Pad Width	0.35	±0.03
T04	Pad Length	1.20	±0.03
T05	Locating Hole Spacing	13.50 (for 38P) 24.30 (for 74P)	±0.05
T06	Locating Hole Diameter	1.30	±0.05
T07	Datum Y to First Row of Solder Pin Holes	2.40	Basic
T08	Datum Y to Second Row of Solder Pin Holes	3.19	Basic
T09	Datum Y to Pad Row A Centerline	1.50	Basic
T10	Datum Y to Pad Row B Centerline	3.10	Basic
T11	Left Solder Pin Hole to Right Solder Pin Hole	14.55 (for 38P) 25.35 (for 74P)	Basic
T12	Left Solder Pin Hole to Right Solder Pin Hole	13.55 (for 38P) 24.35 (for 74P)	Basic
T13	Solder Pin Hole Diameter	0.80	±0.05

A.2.4 Recommended PCB layout for Vertical 124P/148P Connector Footprints

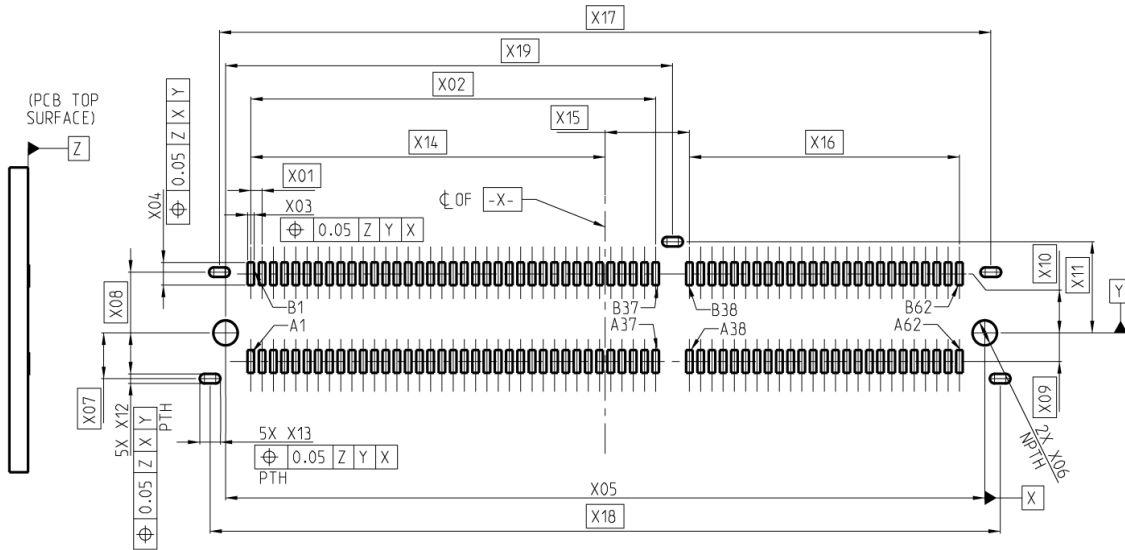

Figure A-4 Recommended Footprints for VT 124P/148P

Table A-4 Recommended Footprint Dimensions for VT 124P/148P

Designator	Description	Dimension (mm)	Tolerance +/-
X01	Pad Pitch	0.60	Basic
X02	First Pad to Last Pad Centers – Port 1	21.60	Basic
X03	Pad Width	0.35	±0.03
X04	Pad Length	1.20	±0.03
X05	Locating Hole Spacing	40.50 (for 124P) 47.70 (for 148P)	±0.05
X06	Locating Hole Diameter	1.30	±0.05
X07	Datum Y to First Row of Solder Pin Hole Slots	2.40	Basic
X08	Datum Y to Second Row of Solder Pin Hole Slots	3.19	Basic
X09	Datum Y to Pad Row A Centerline	1.50	Basic
X10	Datum Y to Pad Row B Centerline	3.10	Basic
X11	Datum Y to Middle Solder Pin Hole Slot	4.79	Basic
X12	Solder Pin Hole Slot Width	0.50 (for 124P) 0.65 (for 148P)	±0.05
X13	Solder Pin Hole Slot Length	1.10 (for 124P) 1.30 (for 148P)	±0.05
X14	Datum X to Pad A1/B1	18.9 (for 124P) 22.5 (for 148P)	Basic
X15	Datum X to Pad A38/B38	4.5 (for 124P) 0.9 (for 148P)	Basic
X16	First Pad to Last Pad Centers – Port 2	14.40 (for 124P) 21.60 (for 148P)	Basic
X17	Solder Pin Hole Slot Spacing	41.15 (for 124P) 48.35 (for 148P)	Basic
X18	Solder Pin Hole Slot Spacing	42.15 (for 124P) 49.35 (for 148P)	Basic
X19	Locating Hole to Middle Solder Pin Hole Slot	23.85	Basic

Appendix B: SMT Connector Solder Lead Geometry (Informative)

Refer to Table B-1 and Figure B-1 for informative SMT solder lead geometry for the connectors.

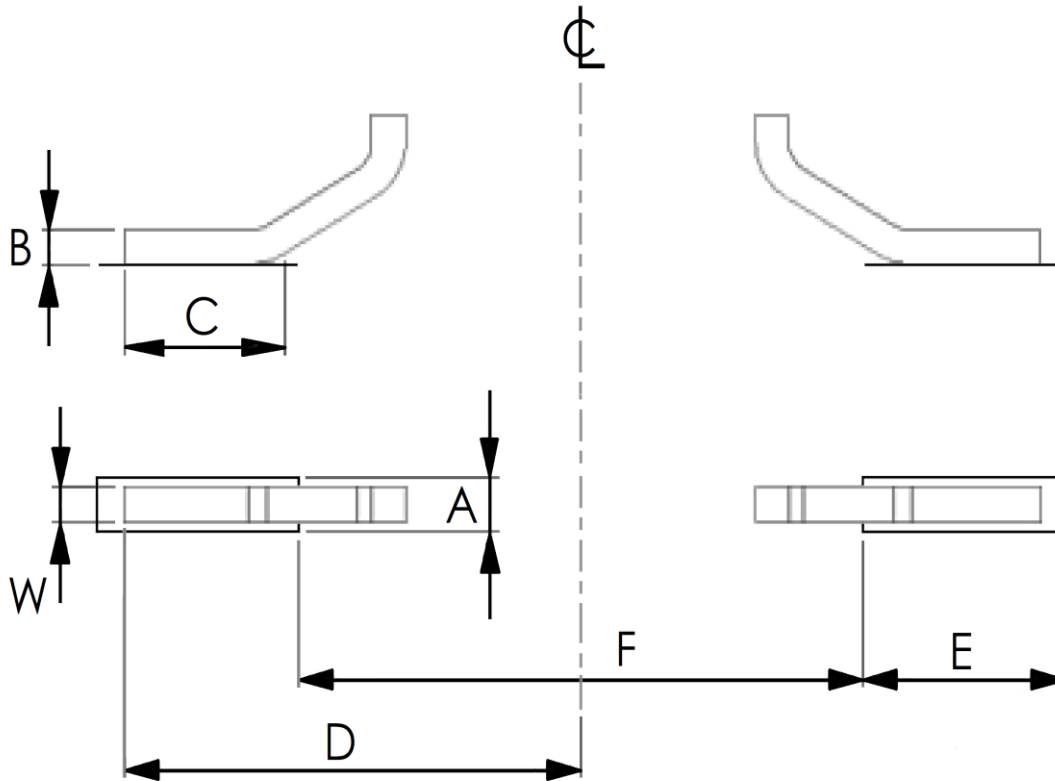

Figure B-1 SMT Lead Geometry

Table B-1 SMT Lead Geometry Dimensions

Variable	Description	Nominal Dimension (mm) For Vertical Connectors	Nominal Dimension (mm) For Right Angle Connectors
A	Pad Width	0.35	0.35
B	Lead Thickness	0.2	0.2
C	Lead Length on Pad	0.97	1.04
D	Lead Trip to Footprint Centerline	2.75	2
E	Pad Length	1.2	1.4
F	Distance Between Inside Edges of Pads	3.4	1.55
W	Lead Width	0.22	0.22

Appendix C: Reference Pinout Diagrams (Informative)

C.1 Overview of Contact Geometry Patterns

The mating plug contains an application specific paddle card that uses a longer pad for any first-mate pad locations (for ground connections) and a shorter pad for any second-mate pad locations (for high speed signals or sidebands). The contacts for the connectors in this specification use a discrete arrangement that allows for repurposing contact locations to allow connectors to be manufactured for multiple applications that require a different allocation of high speed differential pairs and sideband signals. If a connector implementation uses different contact geometry for ground contacts versus high speed signal contacts or sideband signal contacts, then the construction should follow a typical "GSSGSSG" pattern, where each "G" indicates a "ground contact" and each "S" indicates a "high speed signal contact" used for the high speed lanes as shown in Table C-1 while specific contact locations (see typical examples shown in Table C-2 and Table C-3) may use a pattern of "GSbSbSbSbSbG", where each "G" indicates a "ground contact" and each "Sb" indicates a "sideband signal contact" which is used for application specific purposes. All the tables in this appendix show which contacts would use a "ground" type geometry and which contacts would use a "signal" (high speed or sideband) type geometry if and only if the geometry of those contacts are different and these tables are not intended to define an actual pinout. Note, for a given application, the contact locations identified as "GND" type in the connector should correspond with the first-mate pads of the mating plug paddle card for that application.

Table C-1 Connector Contact Types By Location - With No Sidebands

Contact Location	A-Side Contact Types	B-Side Contact Types	Contact Location	Connector Variation	
A74	GND	GND	B74	148 Contact Version	
A73	Signal	Signal	B73		
A72	Signal	Signal	B72		
A71	GND	GND	B71		
A70	Signal	Signal	B70		
A69	Signal	Signal	B69		
A68	GND	GND	B68		
A67	Signal	Signal	B67		
A66	Signal	Signal	B66		
A65	GND	GND	B65		
A64	Signal	Signal	B64		
A63	Signal	Signal	B63		
A62	GND	GND	B62		124 Contact Version
A61	Signal	Signal	B61		
A60	Signal	Signal	B60		
A59	GND	GND	B59		
A58	Signal	Signal	B58		
A57	Signal	Signal	B57		
A56	GND	GND	B56		
A55	Signal	Signal	B55		
A54	Signal	Signal	B54		
A53	GND	GND	B53		
A52	Signal	Signal	B52		
A51	Signal	Signal	B51		
A50	GND	GND	B50		
A49	Signal	Signal	B49		
A48	Signal	Signal	B48		
A47	GND	GND	B47		
A46	Signal	Signal	B46		
A45	Signal	Signal	B45		
A44	GND	GND	B44		

Table C-1 Connector Contact Types By Location - With No Sidebands (continued)

Contact Location	A-Side Contact Types	B-Side Contact Types	Contact Location	Connector Variation					
A43	Signal	Signal	B43	74 Contact Version	124 Contact Version	148 Contact Version			
A42	Signal	Signal	B42						
A41	GND	GND	B41						
A40	Signal	Signal	B40						
A39	Signal	Signal	B39						
A38	GND	GND	B38						
Divider									
A37	GND	GND	B37						
A36	Signal	Signal	B36						
A35	Signal	Signal	B35						
A34	GND	GND	B34						
A33	Signal	Signal	B33						
A32	Signal	Signal	B32						
A31	GND	GND	B31						
A30	Signal	Signal	B30						
A29	Signal	Signal	B29						
A28	GND	GND	B28						
A27	Signal	Signal	B27						
A26	Signal	Signal	B26						
A25	GND	GND	B25						
A24	Signal	Signal	B24						
A23	Signal	Signal	B23						
A22	GND	GND	B22						
A21	Signal	Signal	B21						
A20	Signal	Signal	B20						
A19	GND	GND	B19	38 Contact Version					
A18	Signal	Signal	B18						
A17	Signal	Signal	B17						
A16	GND	GND	B16						
A15	Signal	Signal	B15						
A14	Signal	Signal	B14						
A13	GND	GND	B13						
A12	Signal	Signal	B12						
A11	Signal	Signal	B11						
A10	GND	GND	B10						
A9	Signal	Signal	B9						
A8	Signal	Signal	B8						
A7	GND	GND	B7						
A6	Signal	Signal	B6						
A5	Signal	Signal	B5						
A4	GND	GND	B4						
A3	Signal	Signal	B3						
A2	Signal	Signal	B2						
A1	GND	GND	B1						

Table C-2 Connector Contact Types By Location - With Sidebands

Contact Location	A-Side Contact Types	B-Side Contact Types	Contact Location	Connector Variation	
A74	GND	GND	B74	148 Contact Version	
A73	Signal	Signal	B73		
A72	Signal	Signal	B72		
A71	GND	GND	B71		
A70	Signal	Signal	B70		
A69	Signal	Signal	B69		
A68	GND	GND	B68		
A67	Sideband	Sideband	B67		
A66	Sideband	Sideband	B66		
A65	Sideband	Sideband	B65		
A64	Sideband	Sideband	B64		
A63	Sideband	Sideband	B63		
A62	GND	GND	B62		
A61	Signal	Signal	B61		
A60	Signal	Signal	B60		
A59	GND	GND	B59		
A58	Signal	Signal	B58		
A57	Signal	Signal	B57		
A56	GND	GND	B56		
A55	Signal	Signal	B55		
A54	Signal	Signal	B54		
A53	GND	GND	B53		
A52	Signal	Signal	B52		
A51	Signal	Signal	B51		
A50	GND	GND	B50		
A49	Sideband	Sideband	B49		
A48	Sideband	Sideband	B48		
A47	Sideband	Sideband	B47		
A46	Sideband	Sideband	B46		
A45	Sideband	Sideband	B45		
A44	GND	GND	B44		
A43	Signal	Signal	B43		
A42	Signal	Signal	B42		
A41	GND	GND	B41		
A40	Signal	Signal	B40		
A39	Signal	Signal	B39		
A38	GND	GND	B38		
Divider					

Table C-2 Connector Contact Types By Location - With Sidebands (continued)

Contact Location	A-Side Contact Types	B-Side Contact Types	Contact Location	Connector Variation
A37	GND	GND	B37	74 Contact Version
A36	Signal	Signal	B36	
A35	Signal	Signal	B35	
A34	GND	GND	B34	
A33	Signal	Signal	B33	
A32	Signal	Signal	B32	
A31	GND	GND	B31	
A30	Sideband	Sideband	B30	
A29	Sideband	Sideband	B29	
A28	Sideband	Sideband	B28	
A27	Sideband	Sideband	B27	
A26	Sideband	Sideband	B26	
A25	GND	GND	B25	
A24	Signal	Signal	B24	
A23	Signal	Signal	B23	
A22	GND	GND	B22	
A21	Signal	Signal	B21	
A20	Signal	Signal	B20	
A19	GND	GND	B19	38 Contact Version
A18	Signal	Signal	B18	
A17	Signal	Signal	B17	
A16	GND	GND	B16	
A15	Signal	Signal	B15	
A14	Signal	Signal	B14	
A13	GND	GND	B13	
A12	Sideband	Sideband	B12	
A11	Sideband	Sideband	B11	
A10	Sideband	Sideband	B10	
A9	Sideband	Sideband	B9	
A8	Sideband	Sideband	B8	
A7	GND	GND	B7	
A6	Signal	Signal	B6	
A5	Signal	Signal	B5	
A4	GND	GND	B4	
A3	Signal	Signal	B3	
A2	Signal	Signal	B2	
A1	GND	GND	B1	

148 Contact Version

74 Contact Version

38 Contact Version

Table C-3 Connector Contact Types By Location - With Sidebands for 124P

Contact Location	A-Side Contact Types	B-Side Contact Types	Contact Location	Connector Variation	
A62	GND	GND	B62	124 Contact Version	
A61	Signal	Signal	B61		
A60	Signal	Signal	B60		
A59	GND	GND	B59		
A58	Signal	Signal	B58		
A57	Signal	Signal	B57		
A56	GND	GND	B56		
A55	Signal	Signal	B55		
A54	Signal	Signal	B54		
A53	GND	GND	B53		
A52	Signal	Signal	B52		
A51	Signal	Signal	B51		
A50	GND	GND	B50		
A49	Signal	Signal	B49		
A48	Signal	Signal	B48		
A47	GND	GND	B47		
A46	Signal	Signal	B46		
A45	Signal	Signal	B45		
A44	GND	GND	B44		
A43	Signal	Signal	B43		
A42	Signal	Signal	B42		
A41	GND	GND	B41		
A40	Signal	Signal	B40		
A39	Signal	Signal	B39		
A38	GND	GND	B38		
Divider					
A37	GND	GND	B37		
A36	Signal	Signal	B36		
A35	Signal	Signal	B35		
A34	GND	GND	B34		
A33	Signal	Signal	B33		
A32	Signal	Signal	B32		

Table C-3 Connector Contact Types By Location - With Sidebands for 124P (continued)

Contact Location	A-Side Contact Types	B-Side Contact Types	Contact Location	Connector Variation
A31	GND	GND	B31	124 Contact Version
A30	Sideband	Sideband	B30	
A29	Sideband	Sideband	B29	
A28	Sideband	Sideband	B28	
A27	Sideband	Sideband	B27	
A26	Sideband	Sideband	B26	
A25	GND	GND	B25	
A24	Signal	Signal	B24	
A23	Signal	Signal	B23	
A22	GND	GND	B22	
A21	Signal	Signal	B21	
A20	Signal	Signal	B20	
A19	GND	GND	B19	
A18	Signal	Signal	B18	
A17	Signal	Signal	B17	
A16	GND	GND	B16	
A15	Signal	Signal	B15	
A14	Signal	Signal	B14	
A13	GND	GND	B13	
A12	Sideband	Sideband	B12	
A11	Sideband	Sideband	B11	
A10	Sideband	Sideband	B10	
A9	Sideband	Sideband	B9	
A8	Sideband	Sideband	B8	
A7	GND	GND	B7	
A6	Signal	Signal	B6	
A5	Signal	Signal	B5	
A4	GND	GND	B4	
A3	Signal	Signal	B3	
A2	Signal	Signal	B2	
A1	GND	GND	B1	

C.2 Recommended Cable Assembly Wire Diagrams

The following figures show wiring diagrams for a few of the possible cable assemblies based on these Straight Plugs or Right Angle Plugs at each end of the cable assembly. The particular function for each SIDEBAND is specific to the particular application (e.g. SAS, PCIe, or other). Therefore, whether a particular SIDEBAND actually connects physically from the P1 end to the P2 end of a cable assembly may be specific to the application. Refer to specification SFF-9402, a Reference Guide for Multi-Protocol Internal Cable Pinouts for SAS and/or PCIe, to see pinouts for other similar 38-circuit and 74-circuit connectors, such as the SlimSAS connectors (SFF-8654), as an example of how each SIDEBAND may be used.

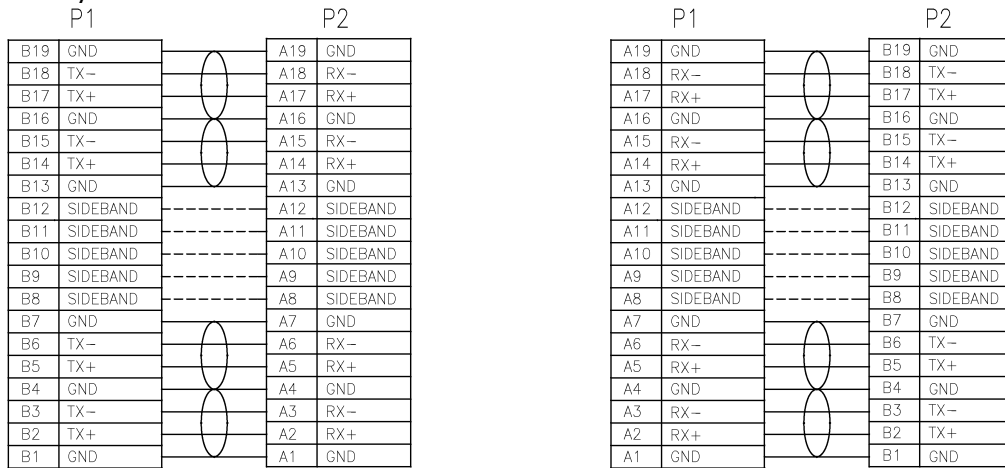

Figure C-1 Sample Wiring Diagram for Cable Assemblies with 38 Contacts

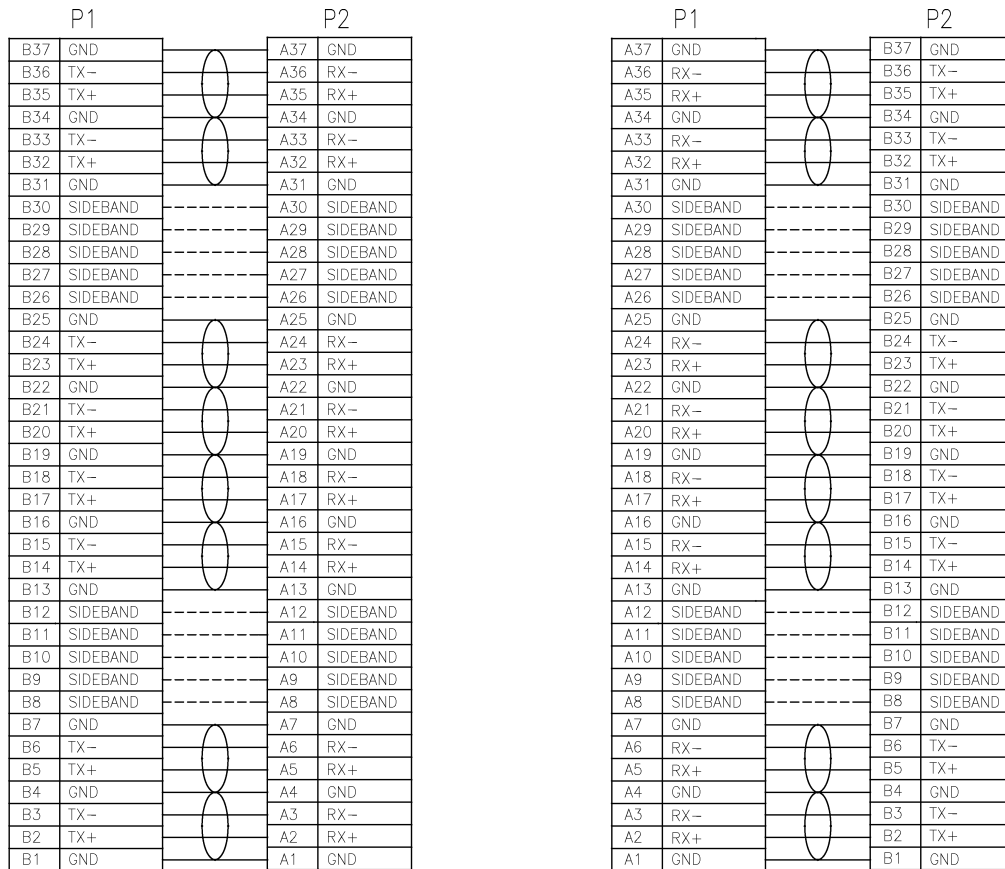

Figure C-2 Sample Wiring Diagram for Cable Assemblies with 74 Contacts

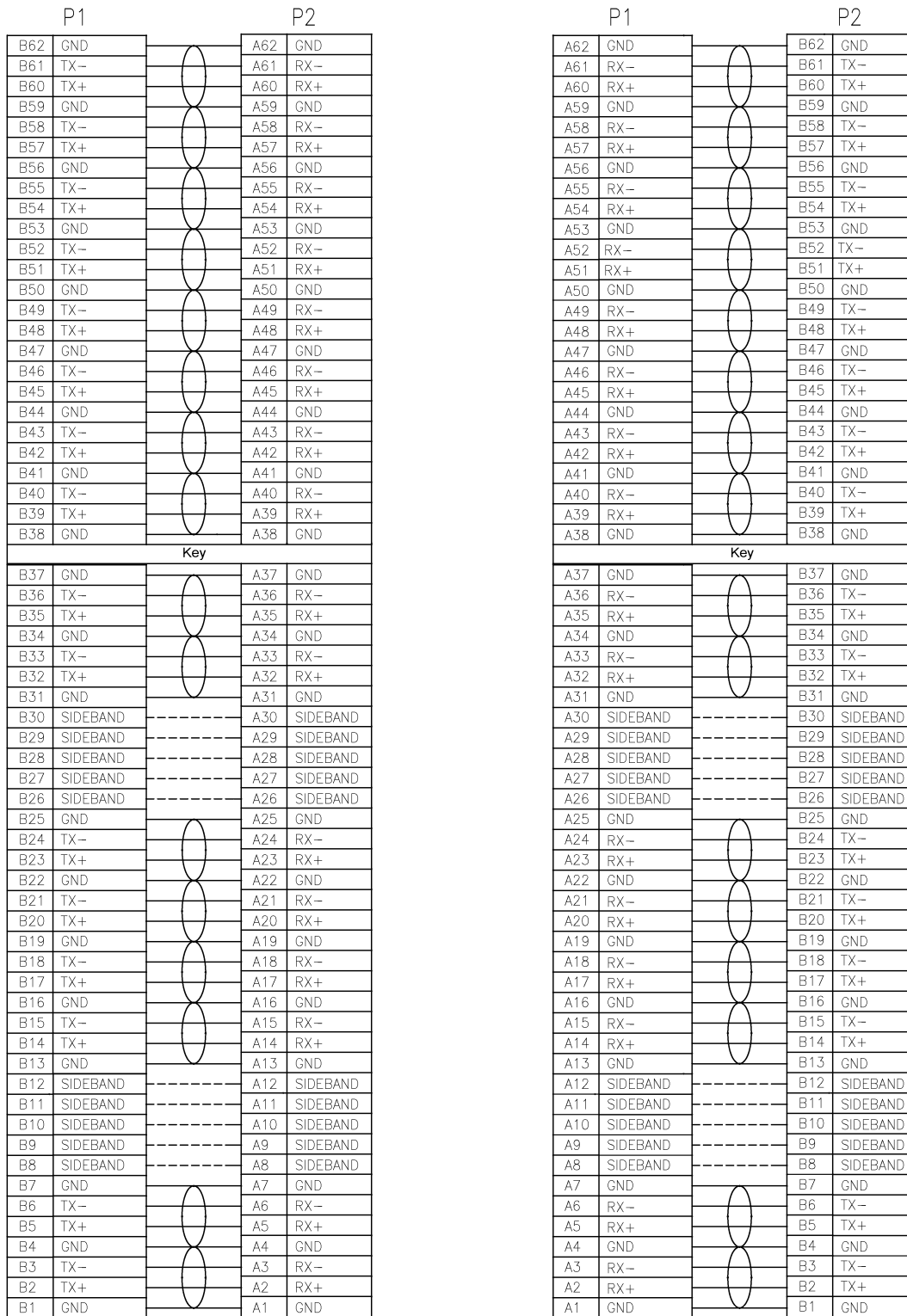

Figure C-3 Sample Wiring Diagram for Cable Assemblies with 124 Contacts

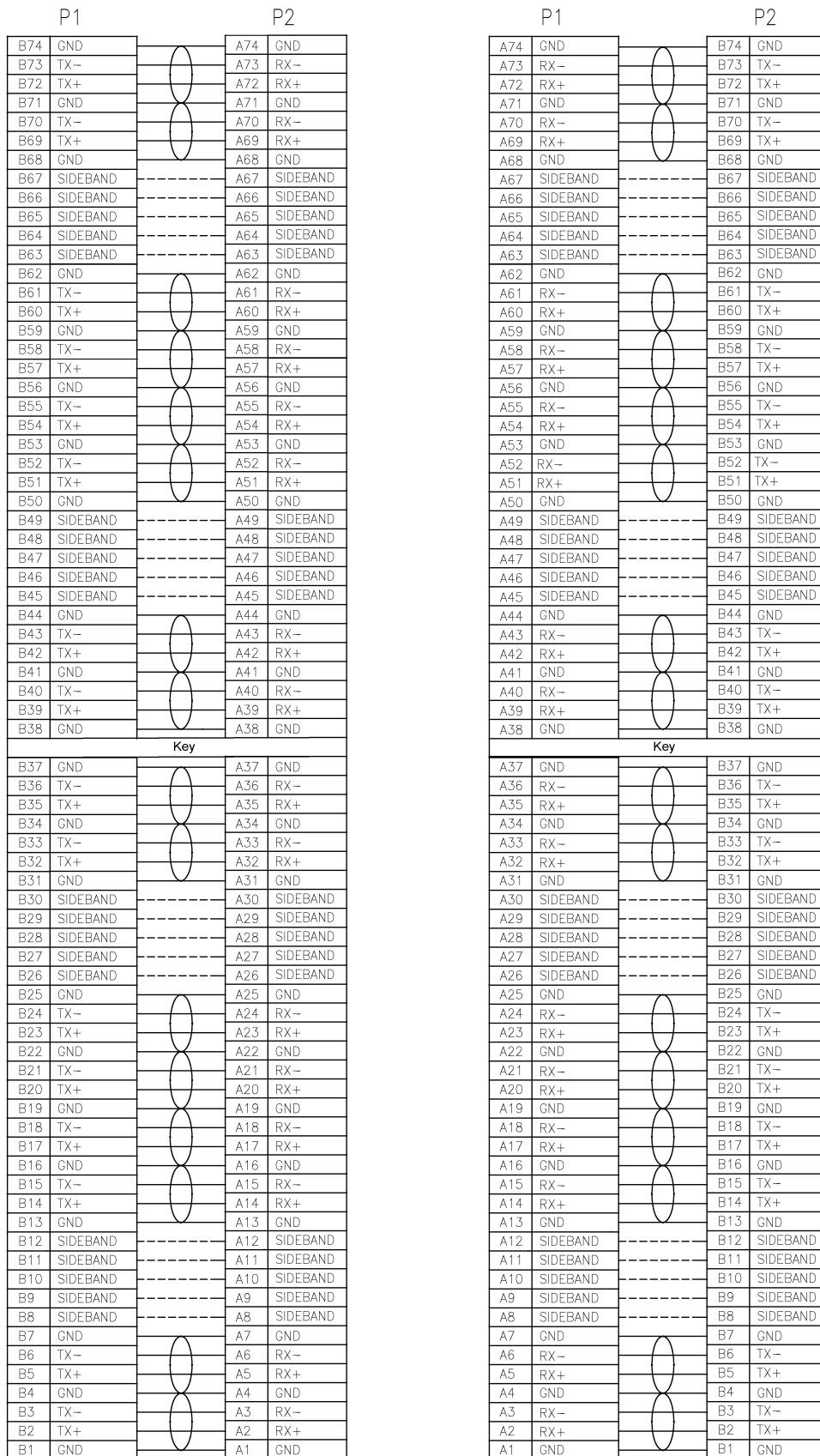

Figure C-4 Sample Wiring Diagram for Cable Assemblies with 148 Contacts

Appendix D: Gatherability (Informative)

Figure D-1 and Figure D-2 show a representation of the linear and angular gatherability of the connectors.

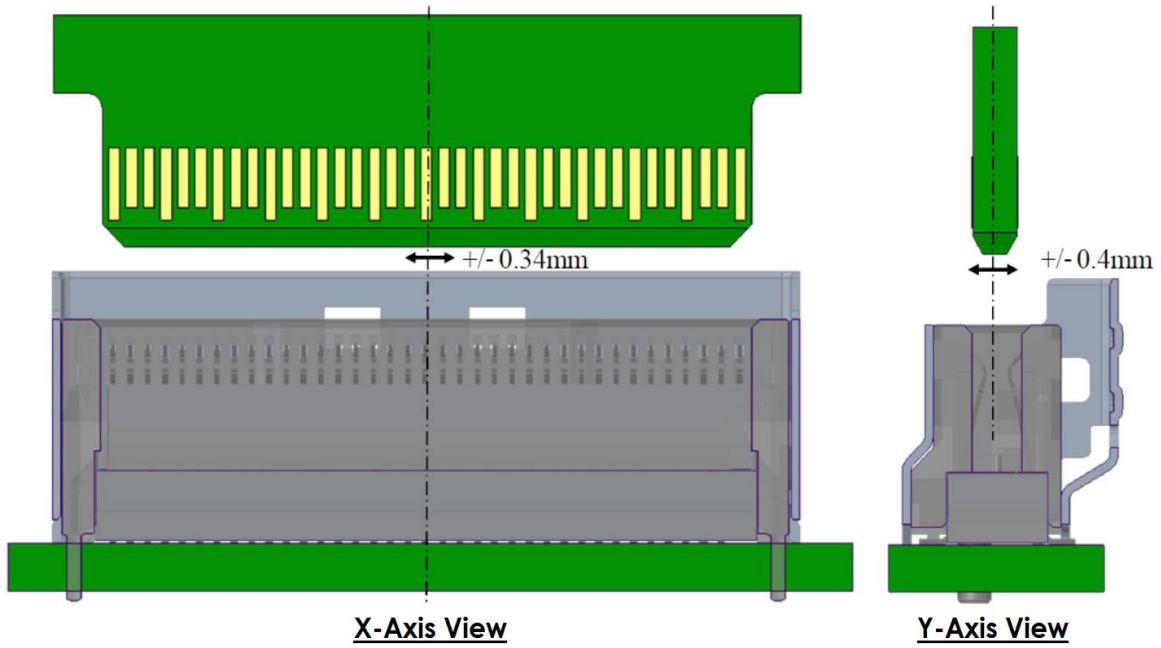

Figure D-1 Linear Gatherability

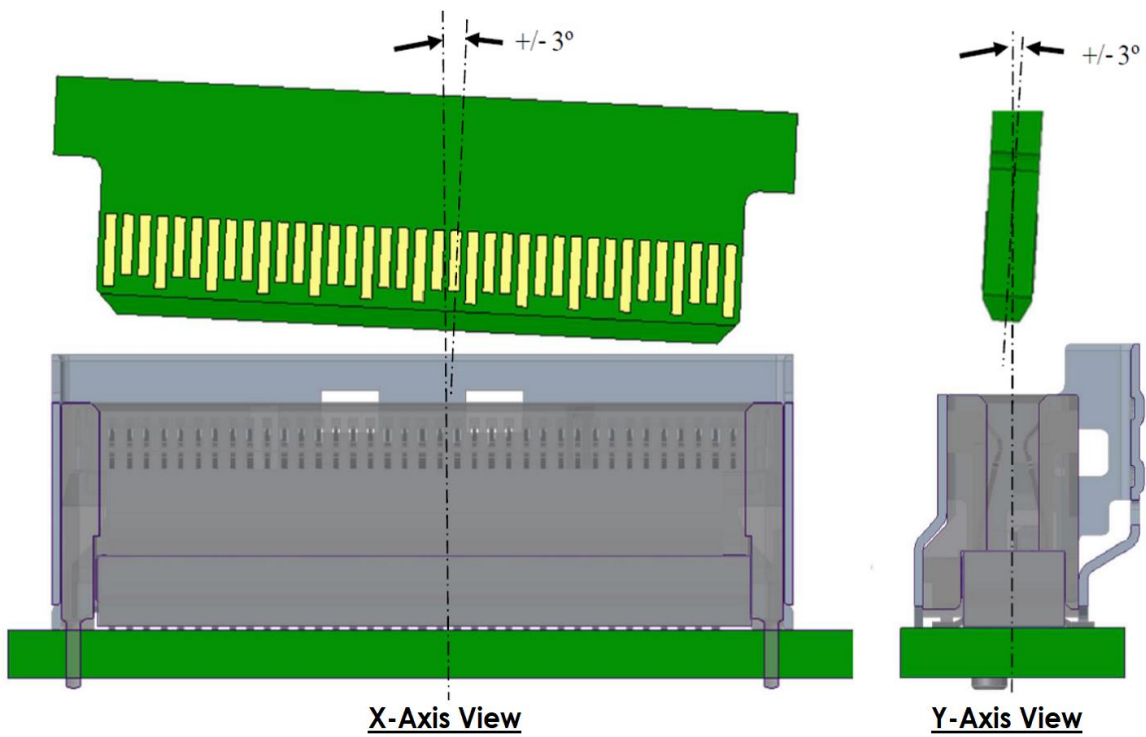

Figure D-2 Angular Gatherability