



# SFF-TA-1014

Specification for

## Fabric Attached Device Connector

Rev 0.0.3

March 21, 2019

SECRETARIAT: SFF TA TWG

This specification is made available for public review at <http://www.snia.org/sff/specifications>. Comments may be submitted at <http://www.snia.org/feedback>. Comments received will be considered for inclusion in future revisions of this specification.

The description of the connector in this specification does not assure that the specific component is available from connector suppliers. If such a connector is supplied, it must comply with this specification to achieve interoperability between suppliers.

**ABSTRACT:** This specification defines the mechanical requirements and general performance requirements for the Fabric Attached Device Connector, a high speed electrical connector system for Open Flex applications. This includes a right angle receptacle, press-fit, 160 position, 8 column, 2.0 mm column pitch, 6 signal pairs per column, and a mating header plug connector with an integrated guide pin.

### POINTS OF CONTACT:

Paul Coddington  
Amphenol Corporation  
20 Valley Street  
Endicott, NY 13760

Chairman SFF TA TWG  
Email: [SFF-Chair@snia.org](mailto:SFF-Chair@snia.org)

Ph: 607-754-4444  
Email: [paul.coddington@amphenol-highspeed.com](mailto:paul.coddington@amphenol-highspeed.com)

## 1 Intellectual Property

2 The user's attention is called to the possibility that implementation of this specification may require the use of an  
3 invention covered by patent rights. By distribution of this specification, no position is taken with respect to the  
4 validity of a claim or claims or of any patent rights in connection therewith.

5  
6 This specification is considered SNIA Architecture and is covered by the SNIA IP Policy and as a result goes  
7 through a request for disclosure when it is published. Additional information can be found at the following  
8 locations:

- 9
- 10 • Results of IP Disclosures: <http://www.snia.org/sffdisclosures>
- 11 • SNIA IP Policy: <http://www.snia.org/ippolicy>
- 12
- 13

## 14 Copyright

15 The SNIA hereby grants permission for individuals to use this document for personal use only, and for  
16 corporations and other business entities to use this document for internal use only (including internal copying,  
17 distribution, and display) provided that:

- 18 1. Any text, diagram, chart, table or definition reproduced shall be reproduced in its entirety with no  
alteration, and,
2. Any document, printed or electronic, in which material from this document (or any portion hereof) is  
reproduced shall acknowledge the SNIA copyright on that material, and shall credit the SNIA for  
granting permission for its reuse.

19  
20 Other than as explicitly provided above, there may be no commercial use of this document, or sale of any part, or  
21 this entire document, or distribution of this document to third parties. All rights not explicitly granted are  
22 expressly reserved to SNIA.

23  
24 Permission to use this document for purposes other than those enumerated (Exception) above may be requested  
25 by e-mailing [copyright\\_request@snia.org](mailto:copyright_request@snia.org). Please include the identity of the requesting individual and/or company  
26 and a brief description of the purpose, nature, and scope of the requested use. Permission for the Exception shall  
27 not be unreasonably withheld. It can be assumed permission is granted if the Exception request is not  
28 acknowledged within ten (10) business days of SNIA's receipt. Any denial of permission for the Exception shall  
29 include an explanation of such refusal.

## 30 Disclaimer

31  
32 The information contained in this publication is subject to change without notice. The SNIA makes no warranty of  
33 any kind with regard to this specification, including, but not limited to, the implied warranties of merchantability  
34 and fitness for a particular purpose. The SNIA shall not be liable for errors contained herein or for incidental or  
35 consequential damages in connection with the furnishing, performance, or use of this specification.

36  
37  
38 Suggestions for revisions should be directed to <http://www.snia.org/feedback/>.

39  
40

1 **Foreword**

2 The development work on this specification was done by the SNIA SFF TWG, an industry group. Since its  
3 formation as the SFF Committee in August 1990, the membership has included a mix of companies which are  
4 leaders across the industry.

5  
6 For those who wish to participate in the activities of the SFF TWG, the signup for membership can be found at  
7 <http://www.snia.org/sff/join>.

8  
9  
10 **Revision History**

- 11
- 12 **Rev 0.0.1** *November 20, 2018:*
- 13 - Initial draft.
- 14 **Rev 0.0.2** *January 24, 2019.*
- 15 - Made some minor editorial changes to add some clarification or to adjust some formatting.
  - 16 Document was updated to SFF Template Rev 1.0.
  - 17 - Removed Editor Notes that are no longer needed.
  - 18 - Replaced Figure 4-3.
  - 19 - Replaced Figure 5-1 and updated Table 5-1 accordingly.
  - 20 - Replaced Figure 5-2 and Figure 5-3 and updated Table 5-2 accordingly.
  - 21 - Replaced Figure 5-4 and Figure 5-5 and updated Table 5-3 accordingly.
  - 22 - Replaced Figure: A-1 and Figure: A-2 and updated Table: A-1 accordingly.
  - 23 - Added Appendix B with all of its figures and tables.
- 24 **Rev 0.0.3** *March 21, 2019.*
- 25 - Minor editorial changes to incorporate comment resolutions in order to prepare the document  
26 for publishing.
- 27  
28  
29

|    |   |    |
|----|---|----|
| 1  | <b>Contents</b>   |    |
| 2  | 1. Scope  | 6  |
| 3  | 2. References and Conventions   | 6  |
| 4  | 2.1 Industry Documents  | 6  |
| 5  | 2.2 Sources   | 6  |
| 6  | 2.3 Conventions   | 7  |
| 7  | 3. Keywords, Acronyms, and Definitions  | 8  |
| 8  | 3.1 Keywords  | 8  |
| 9  | 3.2 Acronyms and Abbreviations  | 8  |
| 10 | 3.3 Definitions   | 9  |
| 11 | 4. General Description  | 11 |
| 12 | 4.1 Configuration Overview/Descriptions   | 11 |
| 13 | 4.1.1 Connector Configuration 1 (Right Angle Receptacle)                                    | 11 |
| 14 | 4.1.2 Connector Configuration 2 (Header/Plug)   | 11 |
| 15 | 4.2 Contact Numbering   | 12 |
| 16 | 5. Connector Mechanical Specification   | 13 |
| 17 | 5.1 Overview  | 13 |
| 18 | 5.1.1 Datums  | 14 |
| 19 | 5.2 Mechanical Description: Right Angle Receptacle Connector                                | 15 |
| 20 | 5.2.1 Right Angle Receptacle Right Guidance Connector                                       | 15 |
| 21 | 5.3 Mechanical Description: Right Angle Header Connector                                    | 18 |
| 22 | 5.3.1 Right Angle Header Right Guidance Connector   | 18 |
| 23 | 6. Performance Requirements   | 21 |
| 24 | 6.1 Performance Tables  | 21 |
| 25 | Appendix A: Recommended Right Angle Receptacle Connector Footprint (Informative)            | 24 |
| 26 | A.1 Overview  | 24 |
| 27 | A.2 Recommended Right Angle Receptacle Right Guidance Connector PCB Layout                  | 24 |
| 28 | A.3 Right Angle Receptacle Right Guidance Connector Attachment Screws                       | 27 |
| 29 | Appendix B: Recommended Right Angle Header Right Guidance Connector Footprint (Informative) | 28 |
| 30 | B.1 Overview  | 28 |
| 31 | B.2 Recommended Right Angle Header Right Guidance Connector PCB Layout                      | 28 |
| 32 | B.3 Right Angle Header Right Guidance Connector Attachment Screws                           | 31 |
| 33 |   |    |
| 34 |   |    |

|    |   |                                     |
|----|---|-------------------------------------|
| 1  | <b>Figures</b>  |                                     |
| 2  | Figure 3-1 Plug and Receptacle Definition                                       | 9                                   |
| 3  | Figure 3-2 Right Angle Connector and Cable Assembly                             | 10                                  |
| 4  | Figure 3-3 Wipe for a Continuous Contact  | 10                                  |
| 5  | Figure 4-1 Right Angle Receptacle Right Guidance Connector                      | 11                                  |
| 6  | Figure 4-2 Example Mating Right Angle Header Right Guidance Connector           | 11                                  |
| 7  | Figure 4-3 Contact Numbering (Right Angle Receptacle Right Guidance Connector)  | 12                                  |
| 8  | Figure 5-1 Datum Definitions  | 14                                  |
| 9  | Figure 5-2 Right Angle Receptacle Right Guidance Connector Front View           | 15                                  |
| 10 | Figure 5-3 Right Angle Receptacle Right Guidance Connector Side View            | 16                                  |
| 11 | Figure 5-4 Right Angle Header Right Guidance Connector Front View               | 18                                  |
| 12 |   |                                     |
| 13 | Figure: A-1 Right Angle Receptacle Right Guidance Footprint                     | 24                                  |
| 14 | Figure: A-3 Keep Out Zone for Integrated Guide                                  | 27                                  |
| 15 | Figure: B-1 Right Angle Header Right Guidance Footprint                         | <b>Error! Bookmark not defined.</b> |
| 16 | Figure: B-2 Right Angle Header Right Guidance Connector Footprint - Detail View | 29                                  |
| 17 | Figure: B-3 Keep Out Zone for Integrated Guide                                  | 31                                  |
| 18 |   |                                     |
| 19 |   |                                     |
| 20 | <b>Tables</b>   |                                     |
| 21 | Table 5-1 Datum Descriptions  | 14                                  |
| 22 | Table 5-2 Right Angle Receptacle Right Guidance Connector Dimensions            | 17                                  |
| 23 | Table 5-3 Right Angle Header Right Guidance Connector Dimensions                | 20                                  |
| 24 | Table 6-1 Form Factor Performance Requirements                                  | 21                                  |
| 25 | Table 6-2 EIA-364-1000 Test Details   | 22                                  |
| 26 | Table 6-3 Additional test Procedures  | 23                                  |
| 27 | Table 6-4 Current Rating  | 23                                  |
| 28 |   |                                     |
| 29 | Table: A-1 Right Angle Receptacle Right Guidance Connector Footprint Dimensions | 26                                  |
| 30 | Table: B-1 Right Angle Header Right Guidance Connector Footprint Dimensions     | 30                                  |
| 31 |   |                                     |
| 32 |   |                                     |
| 33 |   |                                     |

1 **1. Scope**

2 This specification defines the Fabric Attached Device right angle receptacle connector and a mating header plug  
3 connector. This includes a connector overview, mechanical descriptions, general performance testing  
4 requirements, and recommendations for PCB footprints and keep-out zones.

5 **2. References and Conventions**

6 **2.1 Industry Documents**

- 7 - ASME-Y14.5 Geometric Dimensioning and Tolerancing
- 8 - EIA-364-1000 Environmental Test Methodology for Assessing the Performance of Electrical Connectors  
9 and Sockets Used in Controlled Environment Applications
- 10 - SFF-TA-1013 Fabric Attached Device Form Factor
- 11 - SFF-TA-1015 Fabric Attached Device Connector Pinout

12 **2.2 Sources**

13 The complete list of SFF documents which have been completed, are currently being worked on, or that have  
14 been expired by the SFF Committee can be found at <http://www.snia.org/sff/specifications>. Suggestions for  
15 improvement of this specification will be welcomed. They should be submitted to <http://www.snia.org/feedback>.

16  
17  
18 Copies of ASME standards may be obtained from the American Society of Mechanical Engineers  
19 (<https://www.asme.org>).

20  
21 Copies of Electronic Industries Alliance (EIA) standards may be obtained from the Electronic Components  
22 Industry Association (ECIA) (<https://www.ecianow.org>).

23  
24

1 **2.3 Conventions**

2 The following conventions are used throughout this document:

3  
4 **DEFINITIONS**

5 Certain words and terms used in this standard have a specific meaning beyond the normal English meaning.  
6 These words and terms are defined either in the definitions or in the text where they first appear.

7  
8 **ORDER OF PRECEDENCE**

9 If a conflict arises between text, tables, or figures, the order of precedence to resolve the conflicts is text; then  
10 tables; and finally figures. Not all tables or figures are fully described in the text. Tables show data format and  
11 values.

12  
13 **LISTS**

14 Lists sequenced by lowercase or uppercase letters show no ordering relationship between the listed items.

15  
16 EXAMPLE 1 - The following list shows no relationship between the named items:

- 17 a. red (i.e., one of the following colors):
  - 18 A. crimson; or
  - 19 B. pink;
- 20 b. blue; or
- 21 c. green.

22  
23 Lists sequenced by numbers show an ordering relationship between the listed items.

24  
25 EXAMPLE 2 -The following list shows an ordered relationship between the named items:

- 26 1. top;
- 27 2. middle; and
- 28 3. bottom.

29  
30 Lists are associated with an introductory paragraph or phrase, and are numbered relative to that paragraph or  
31 phrase (i.e., all lists begin with an a. or 1. entry).

32  
33 **DIMENSIONING CONVENTIONS**

34 The dimensioning conventions are described in ASME-Y14.5, Geometric Dimensioning and Tolerancing. All  
35 dimensions are in millimeters, which are the controlling dimensional units (if inches are supplied, they are for  
36 guidance only).

37  
38 **NUMBERING CONVENTIONS**

39 The ISO convention of numbering is used i.e., the thousands and higher multiples are separated by a space and a  
40 period is used as the decimal point. This is equivalent to the English/American convention of a comma and a  
41 period.

| American    | French      | ISO         |
|-------------|-------------|-------------|
| 0.6         | 0,6         | 0.6         |
| 1,000       | 1 000       | 1 000       |
| 1,323,462.9 | 1 323 462,9 | 1 323 462.9 |

### 3. Keywords, Acronyms, and Definitions

For the purposes of this document, the following keywords, acronyms, and definitions apply.

#### 3.1 Keywords

**May/ may not:** Indicates flexibility of choice with no implied preference.

**Shall:** Indicates a mandatory requirement. Designers are required to implement all such mandatory requirements to ensure interoperability with other products that conform to this specification.

**Should:** Indicates flexibility of choice with a strongly preferred alternative.

#### 3.2 Acronyms and Abbreviations

**AOC:** Active Optical Cable

**EMLB:** Early Mate Late Break

**IDC:** Insulation Displacement Contact

**IDT:** Insulation Displacement Termination

**PCB:** Printed Circuit Board

**PF:** Press Fit

**PTH:** Plated Through Hole

**RA:** Right Angle

**RAH:** Right Angle Header

**RAR:** Right Angle Receptacle

**SMT:** Surface Mount Technology

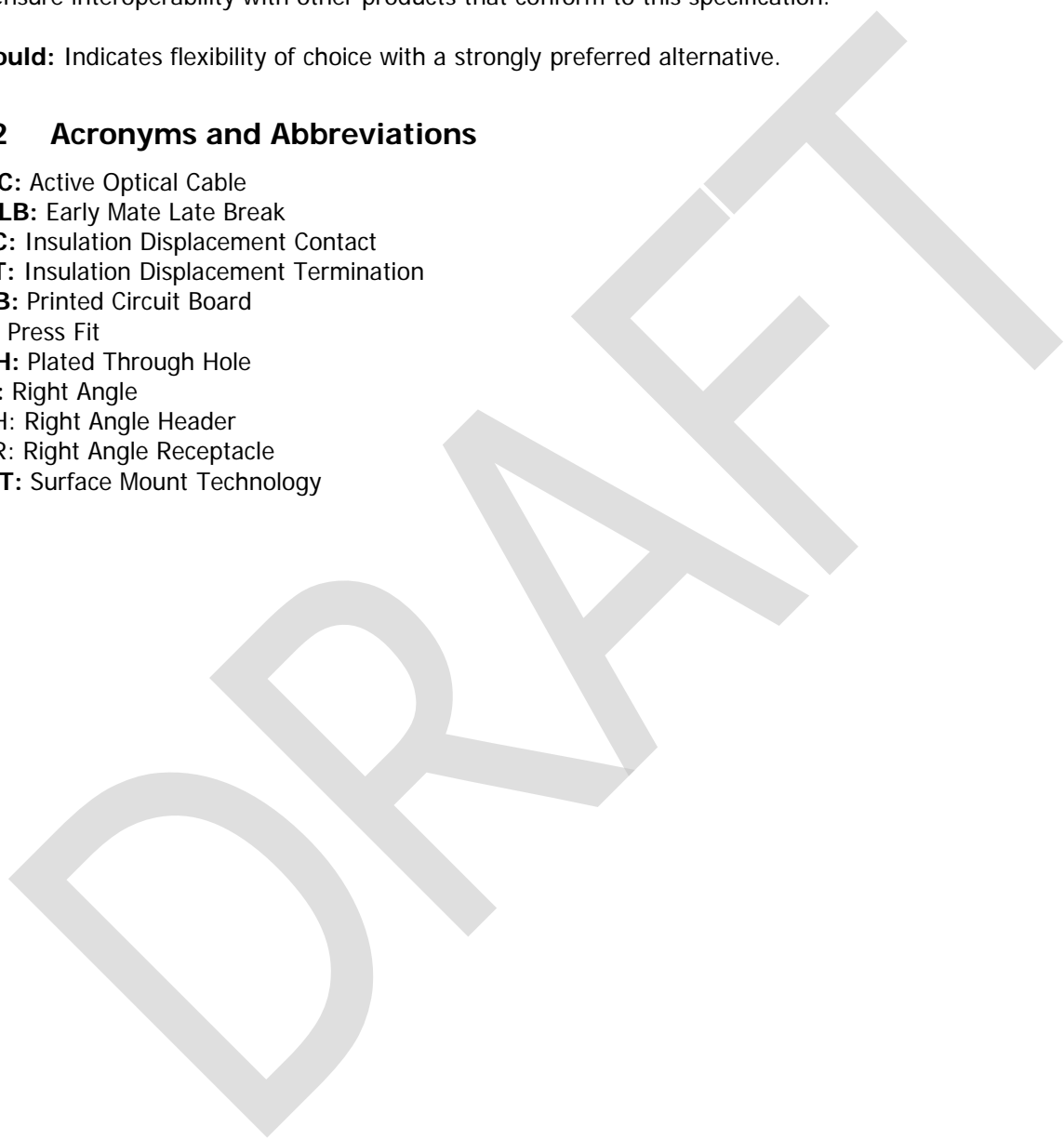



### 3.3 Definitions

**Alignment guides:** A term used to describe features that pre-align the two halves of a connector interface before electrical contact is established. Other common terms include: guide pins, guide posts, blind mating features, mating features, alignment features, and mating guides.

**Connector:** Each half of an interface that, when joined together, establish electrical contact and mechanical retention between two components. In this specification, the term connector does not apply to any specific gender; it is used to describe the receptacle, the plug or the card edge, or the union of receptacle to plug or card edge. Other common terms include: connector interface, mating interface, and separable interface.

**Contact mating sequence:** A term used to describe the order of electrical contact established/ terminated during mating/un-mating. Other terms include: contact sequencing, contact positioning, mate first/break last, EMLB (early mate late break) staggered contacts, and long pin/short pin.

**Contacts:** A term used to describe connector terminals that make electrical connections across a separable interface.

**Module:** In this specification, module may refer to a plug assembly at the end of a copper (electrical) cable (passive or active), an active optical cable (AOC), an optical transceiver, or a loopback.

**Plug:** A term used to describe the connector that contains the penetrating contacts of the connector interface as shown in Figure 3-1. Plugs typically contain stationary contacts. Other common terms include male, pin connector, and card edge.

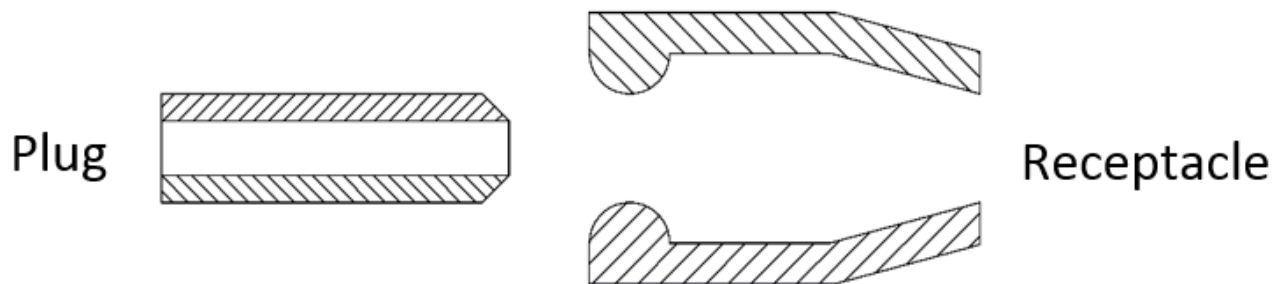

Figure 3-1 Plug and Receptacle Definition

**Plated through hole termination:** A term used to describe a termination style in which rigid pins extend into or through the PCB. Pins are soldered to keep the connector or cage in place. Other common terms are through hole or PTH.

**Press fit:** A term used to describe a termination style in which collapsible pins penetrate the surface of a PCB. Upon insertion, the pins collapse to fit inside the PCB's plated through holes. The connector or cage is held in place by the interference fit between the collapsed pins and the PCB.

**Receptacle:** A term used to describe the connector that contains the contacts that accept the plug contacts as shown in Figure 3-1. Receptacles typically contain spring contacts. Other common terms include female and socket connector.

**Right Angle:** A term used to describe either a connector design where the mating direction is parallel to the plane of the printed circuit board upon which the connector is mounted or a cable assembly design where the mating direction is perpendicular to the bulk cable. Examples are shown in Figure 3-2.

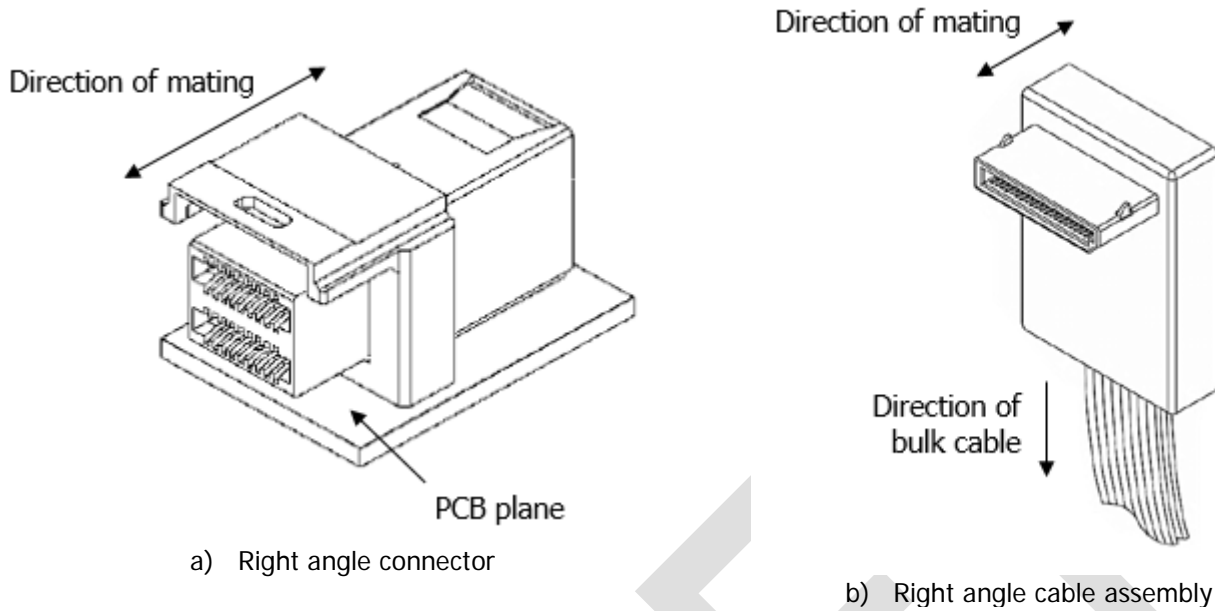

**Figure 3-2 Right Angle Connector and Cable Assembly**

**Straight:** A term used to describe a connector design where the mating direction is parallel to the bulk cable.

**Surface mount:** A term used to describe a termination style in which pins sit on pads on the surface of a PCB and are then soldered to keep the connector or cage in place. Other common terms are surface mount technology or SMT.

**Termination:** A term used to describe a connector's non-separable attachment point such as a connector contact to a PCB. Common PCB terminations include: surface mount (SMT), plated through hole termination (PTH), and press fit (PF). Common cable terminations include insulation displacement contact (IDC), insulation displacement termination (IDT), wire slots, solder, welds, crimps, and brazes.

**Wipe:** The distance a contact travels on the surface of its mating contact during the mating cycle as shown in Figure 3-3.

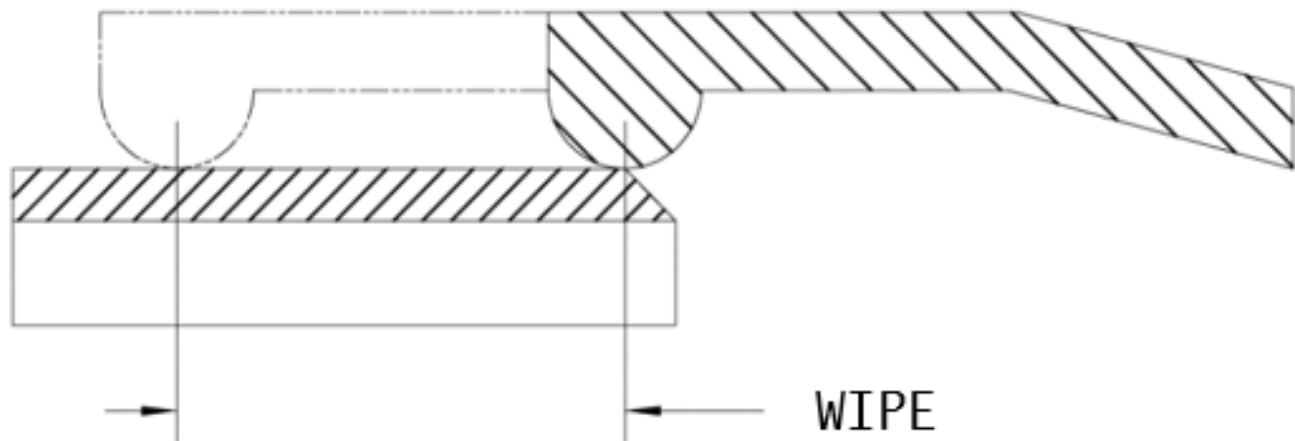

**Figure 3-3 Wipe for a Continuous Contact**

## 4. General Description

### 4.1 Configuration Overview/Descriptions

This specification details a connector system including a press-fit, right angle receptacle connector with 160 contact positions and an integrated guidance feature and a mating header/plug connector with an integrated guide pin.

#### 4.1.1 Connector Configuration 1 (Right Angle Receptacle)

Configuration 1 is a press fit, right angle receptacle connector. A sample of this right angle receptacle, right guidance connector is shown in Figure 4-1 and it shall mate with a header/plug connector like the one shown in Figure 4-2.

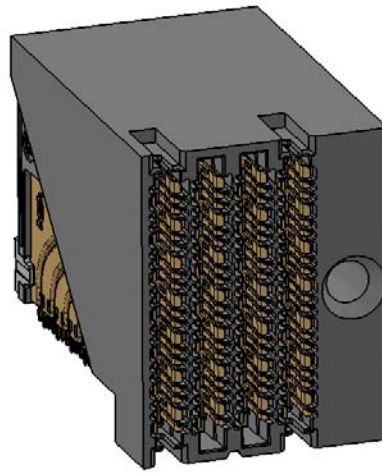

Figure 4-1 Right Angle Receptacle Right Guidance Connector

#### 4.1.2 Connector Configuration 2 (Header/Plug)

Configuration 2 is a header right guidance connector that mates with Configuration 1. The header connector may be a right angle version header connector, as shown in Figure 4-2, but could also be a straight header connector or some other version in order to fit the needs of the particular application.

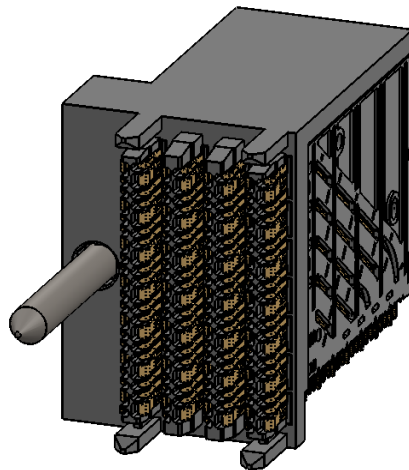

Figure 4-2 Example Mating Right Angle Header Right Guidance Connector

The right guidance feature means that the guide pin on the left side corresponds with the right guidance hole on

1 the right side of the mating receptacle connector.

2 **4.2 Contact Numbering**

3 The electrical contacts in this connector interface are arranged in 20 rows and 8 columns and are numbered as  
4 shown in Figure 4-3. Positions A1 and A7 are EMLB (Early Mate Late Break) contact locations.  
5  
6

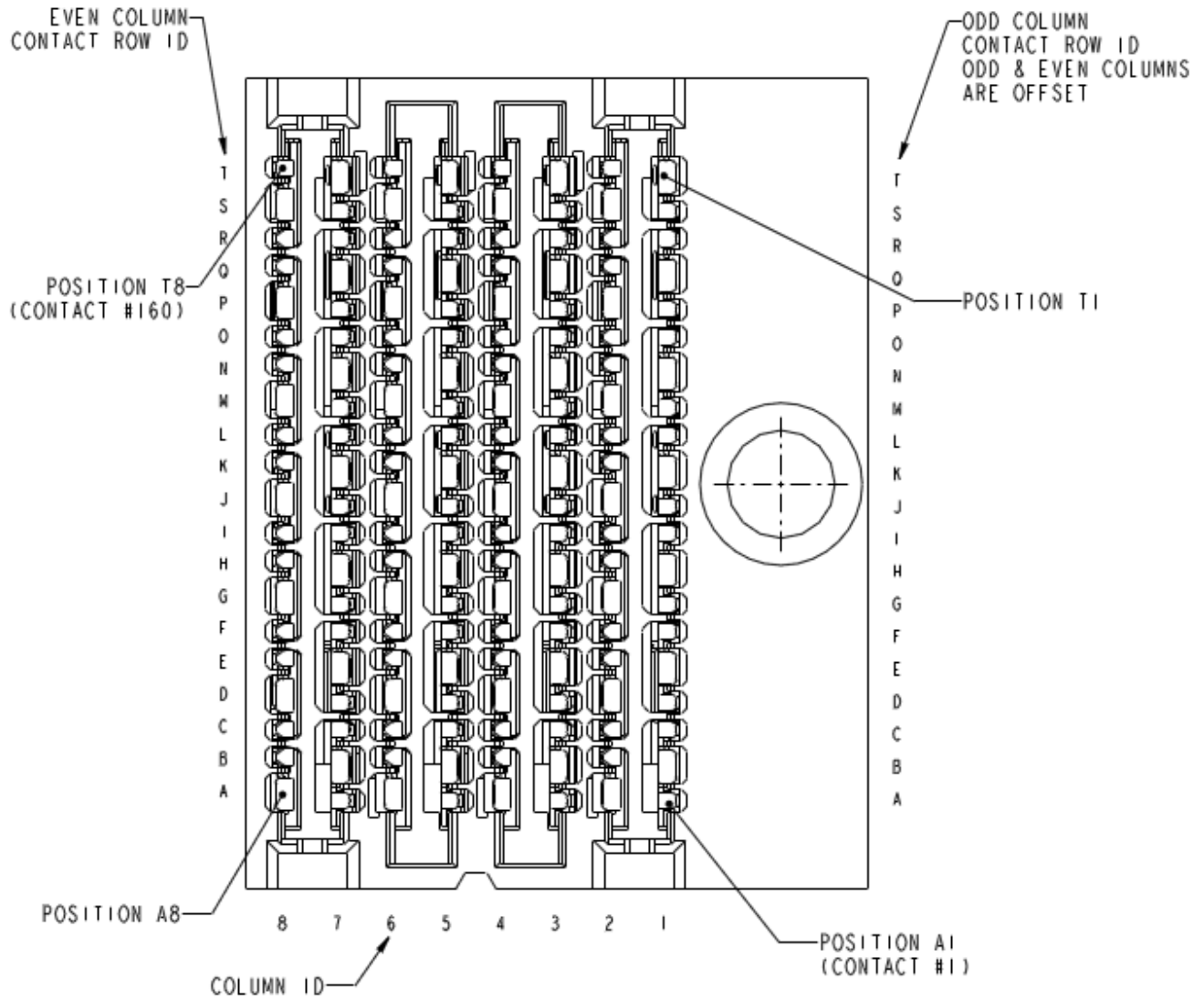

7  
8 **Figure 4-3 Contact Numbering (Right Angle Receptacle Right Guidance Connector)**  
9  
10

## 5. Connector Mechanical Specification

### 5.1 Overview

The Fabric Attached Device connector is a high speed electrical connector system for backplane, coplanar, and orthogonal applications. The connector system utilizes a Right Angle Receptacle (RAR) and a mating header plug connector. The Fabric Attached Device connectors use compliant press-fit tails to provide a reliable electrical connection between the connector and the plated through holes (PTH) of the PCB. For signal terminals, the Fabric Attached Device connector product has a small press-fit section that uses  $\text{\O}0.36\text{mm}$  finished through holes while the ground terminals use a larger standard press-fit section with  $\text{\O}0.50\text{mm}$  finished through holes. In addition to the signal pairs and grounds, there is a single low speed signal contact at the end of each column that may be utilized for various low speed signals and/or low power requirements. These locations also have the small press-fit section and use  $\text{\O}0.36\text{mm}$  finished through holes.

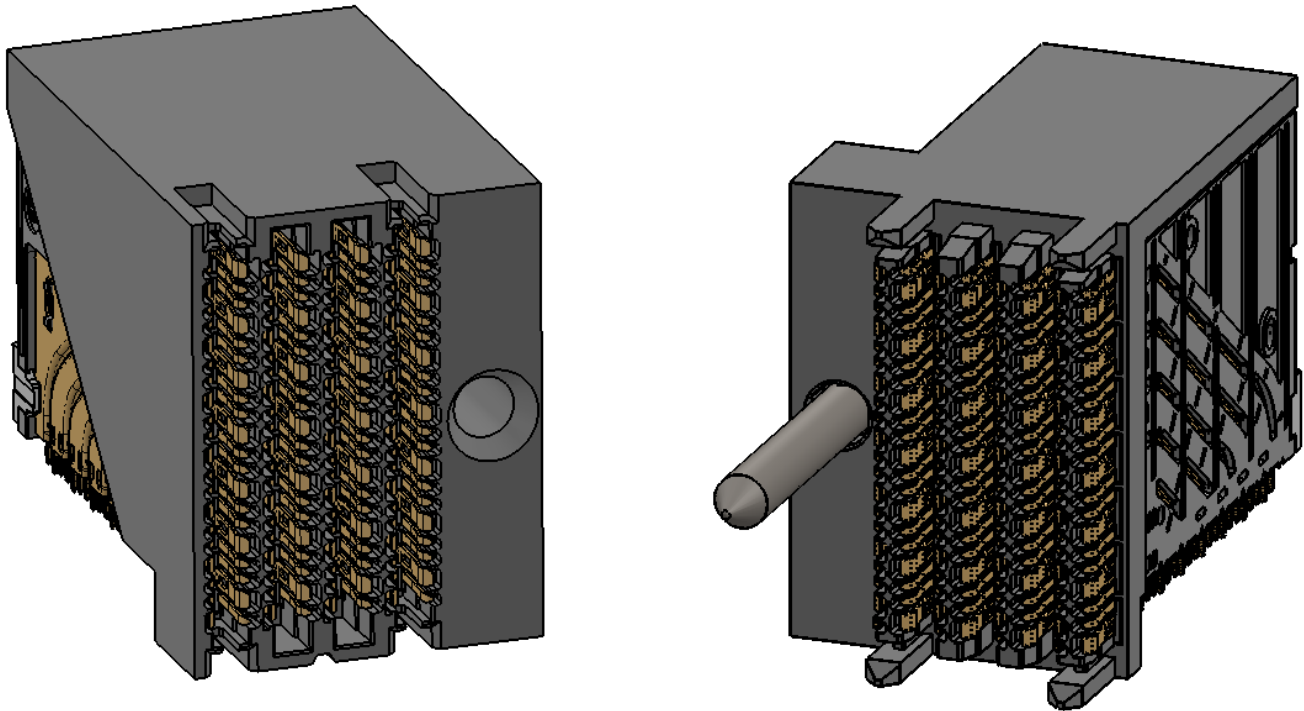

12  
13  
14  
15

1 **5.1.1 Datums**

2 The datums defined in Figure 5-1 and Table 5-1 may be used throughout the rest of the document to describe  
 3 the dimensional requirements of this connector.  
 4

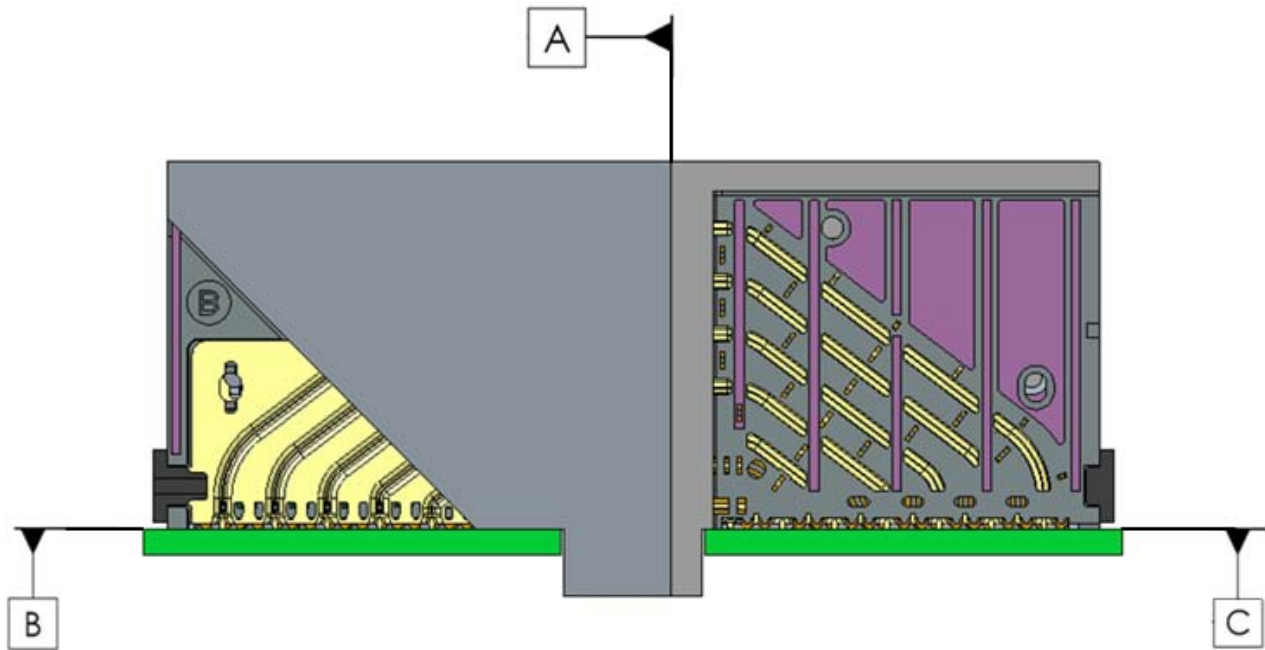

5  
 6 **Figure 5-1 Datum Definitions**

7  
 8  
 9 **Table 5-1 Datum Descriptions**

| Datum | Descriptions   |
|-------|--|
| A     | Mating surface   |
| B     | Fabric Attached Device pcb top surface                         |
| C     | Coplanar RAH board top surface                                 |
| U     | Vertical centerline of RAH guide post slot distance on Datum A |
| X     | Vertical centerline of RAR guide post distance on Datum A      |

10

1 5.2 Mechanical Description: Right Angle Receptacle Connector

2 5.2.1 Right Angle Receptacle Right Guidance Connector

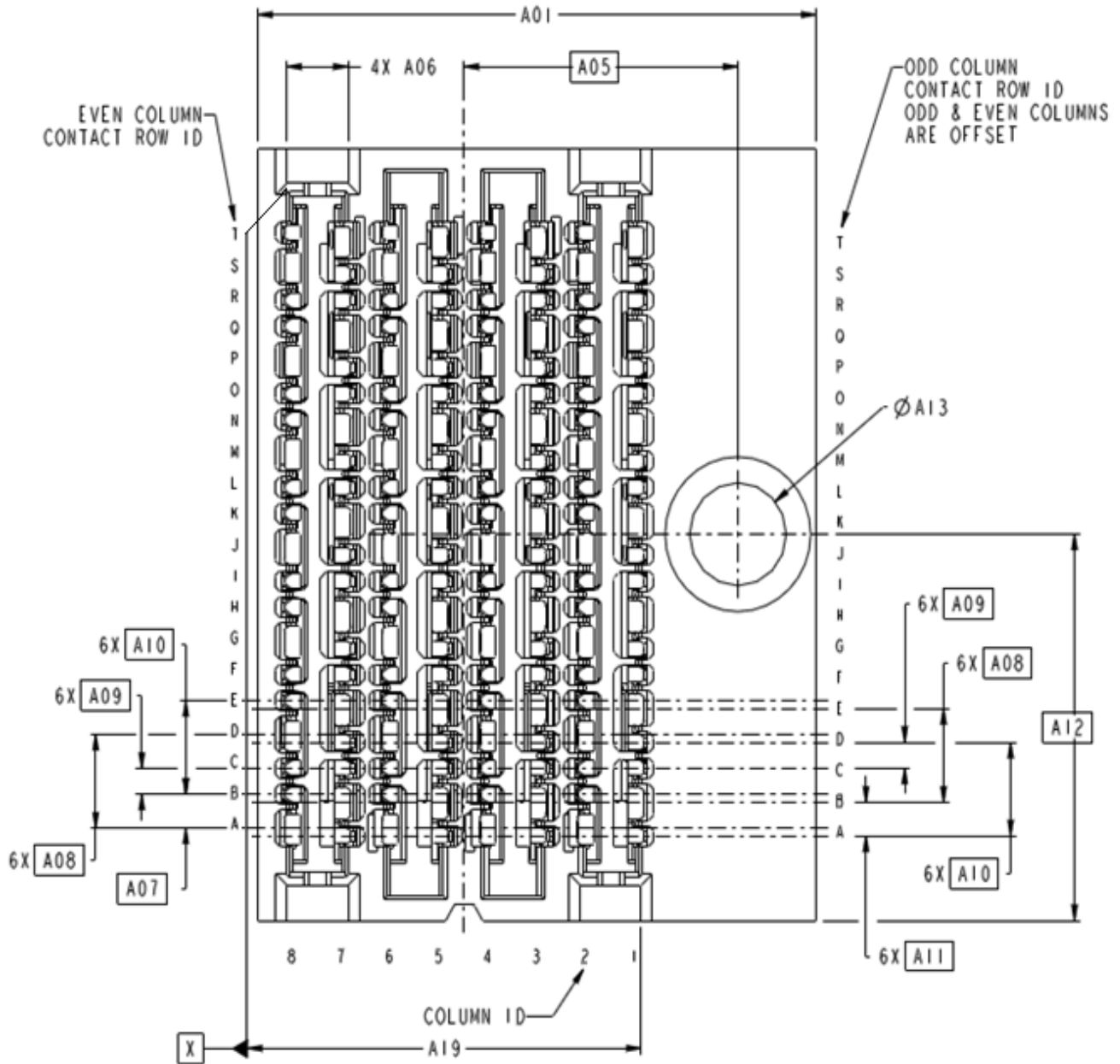

3  
4  
5  
6  
Figure 5-2 Right Angle Receptacle Right Guidance Connector Front View

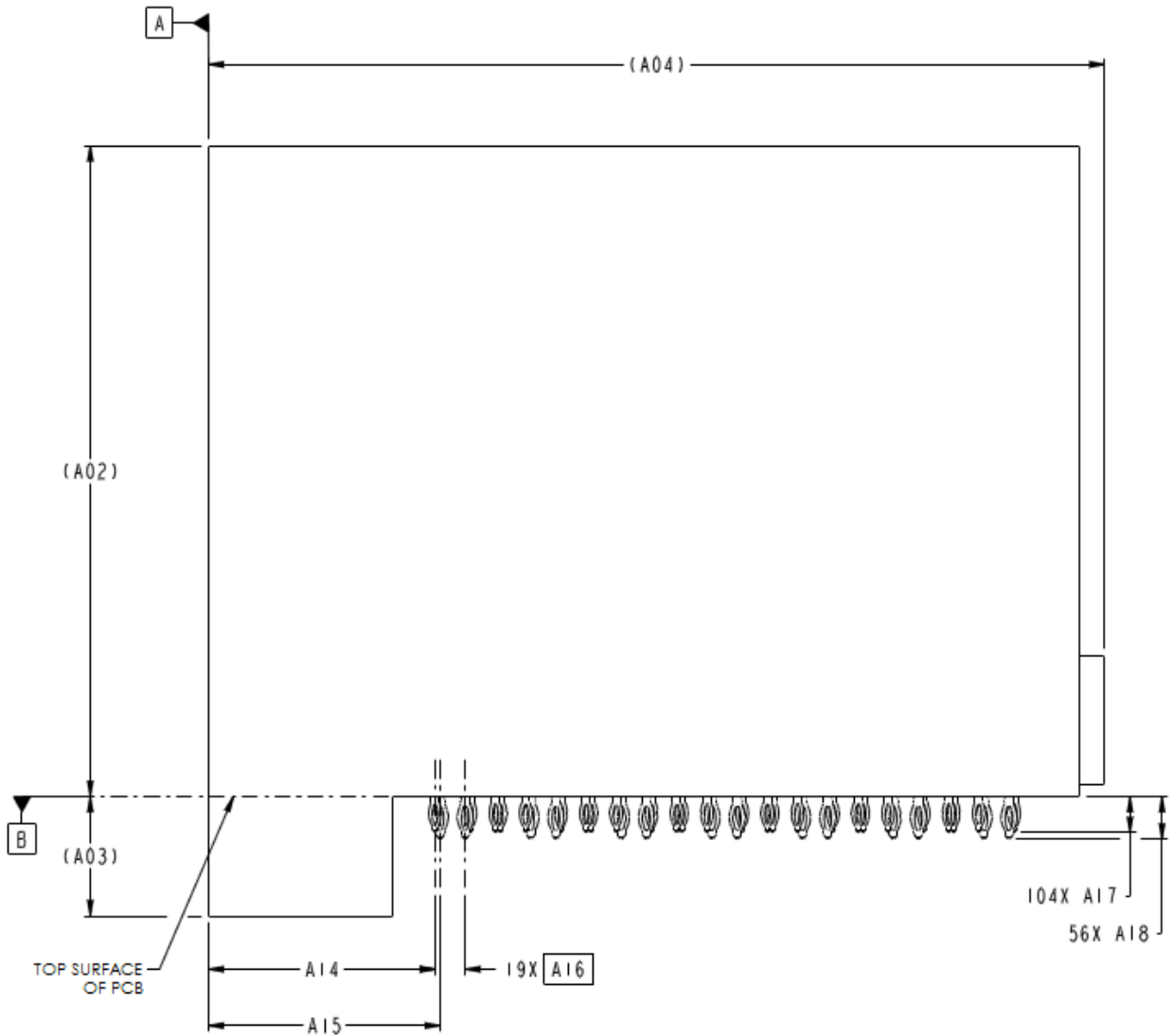

1  
2  
3  
4  
5  
6

Figure 5-3 Right Angle Receptacle Right Guidance Connector Side View



1

**Table 5-2 Right Angle Receptacle Right Guidance Connector Dimensions**

| Designator | Description                                       | Dimension(mm) | Tolerance +/- |
|------------|---|---------------|---------------|
| A01        | RAR connector width                               | 22.85         | +/-0.10       |
| A02        | RAR connector height from Datum B                 | 25.10         | Ref           |
| A03        | Height from Datum B to RAR housing bottom         | 4.60          | Ref           |
| A04        | RAR connector length from Datum A                 | 35.60         | Ref           |
| A05        | RAR hole center to Datum X                        | 11.2          | Basic         |
| A06        | RAR housing slot width                            | 2.5           | +/-0.05       |
| A07        | Even column row A centers to first signal centers | 1.3           | Basic         |
| A08        | Ground centers                                    | 3.6           | Basic         |
| A09        | Signal pair centers                               | 1.0           | Basic         |
| A10        | Signal centers                                    | 3.6           | Basic         |
| A11        | Odd column row A centers to first ground centers  | 1.3           | Basic         |
| A12        | RAR guide hole center to housing bottom surface   | 14.85         | Basic         |
| A13        | RAR guide hole diameter                           | 3.95          | +/-0.10       |
| A14        | Datum A to centers of odd columns                 | 9.00          | +/-0.15       |
| A15        | Datum A to centers of even columns                | 9.20          | +/-0.15       |
| A16        | Pitch within each column                          | 1.20          | Basic         |
| A17        | Signals tail length                               | 1.40          | +/-0.20       |
| A18        | Grounds tail length                               | 1.60          | +/-0.20       |
| A19        | RAR housing guide post slot distance              | 14.50         | +/-0.05       |

2

3

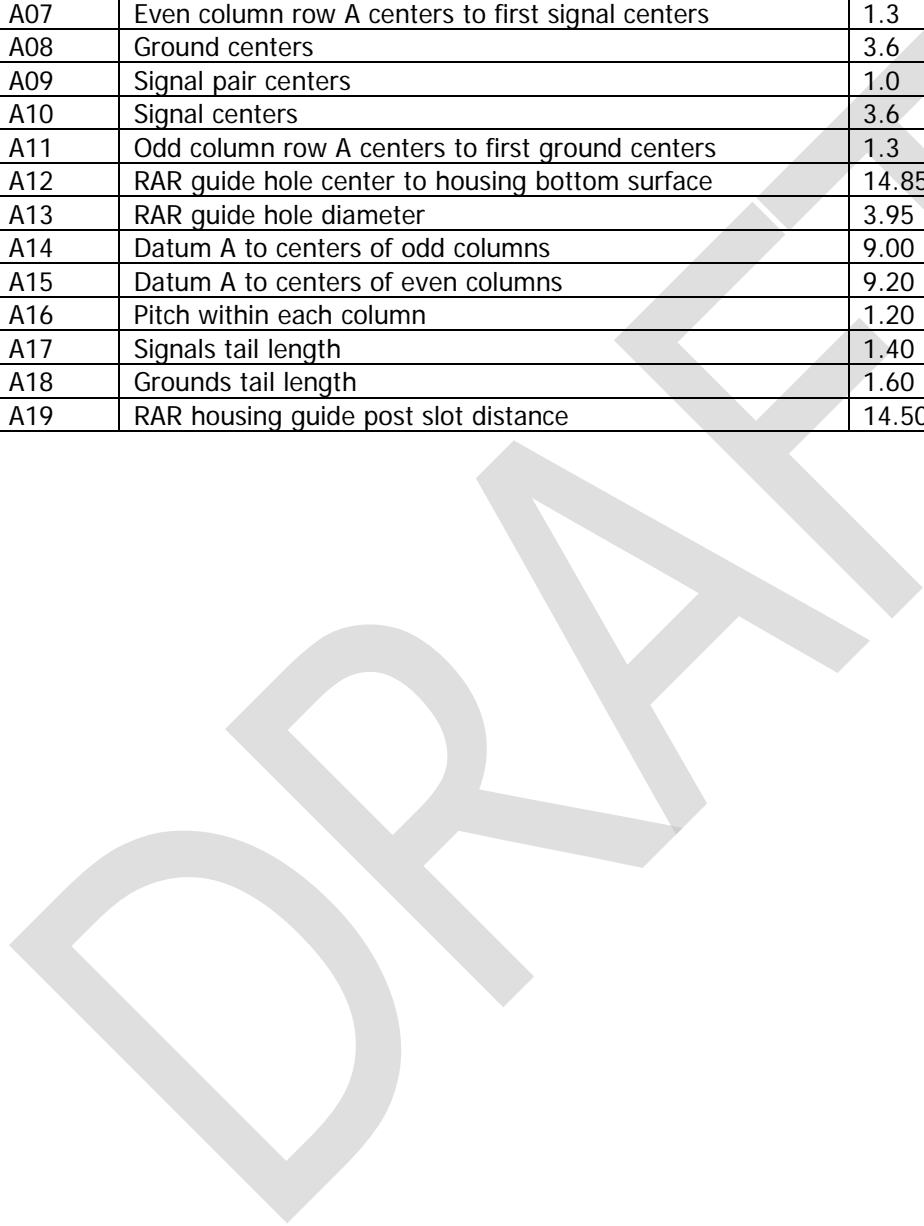

1 **5.3 Mechanical Description: Right Angle Header Connector**

2 **5.3.1 Right Angle Header Right Guidance Connector**

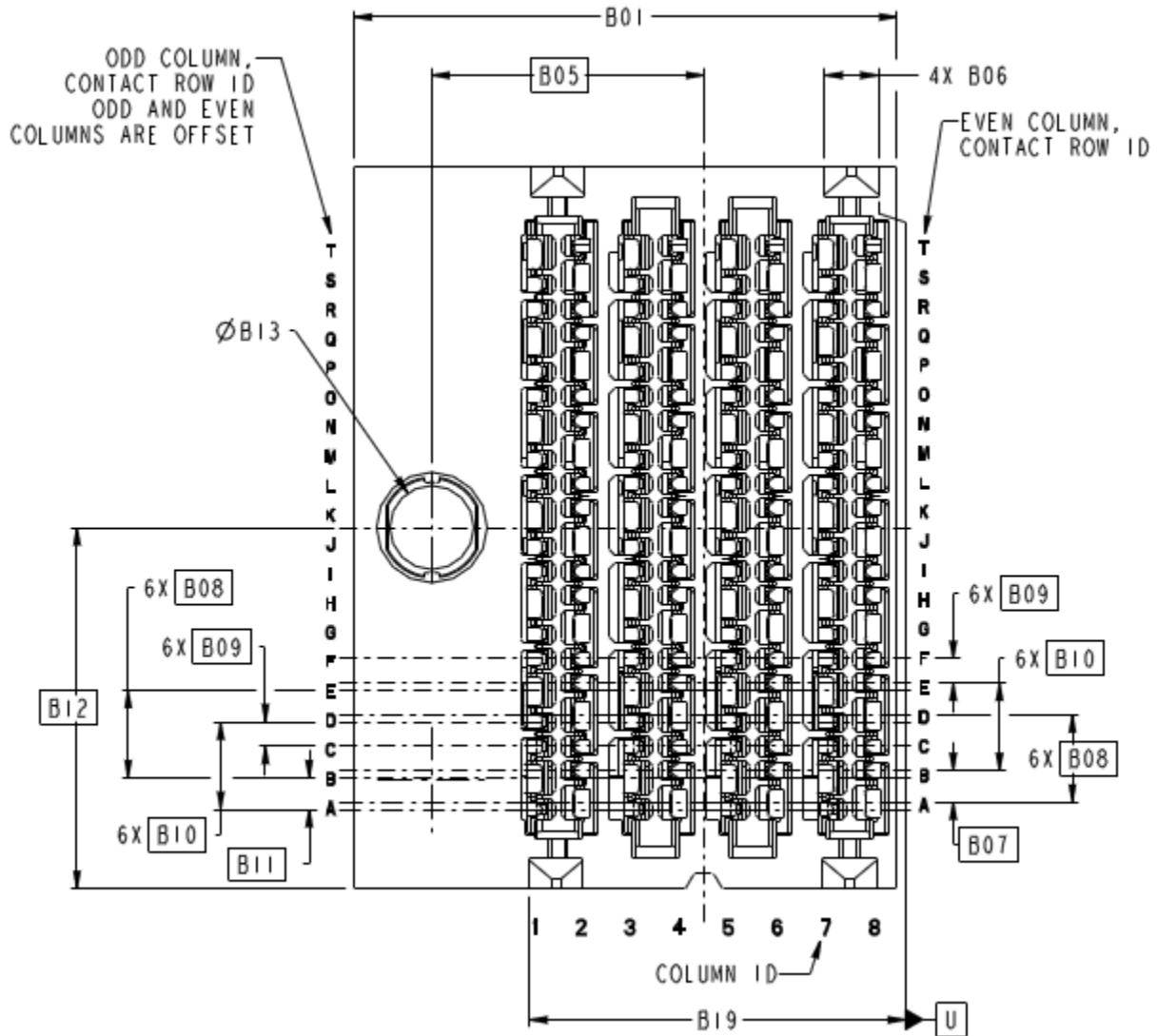

3 **Figure 5-4 Right Angle Header Right Guidance Connector Front View**

4  
5

1  
2

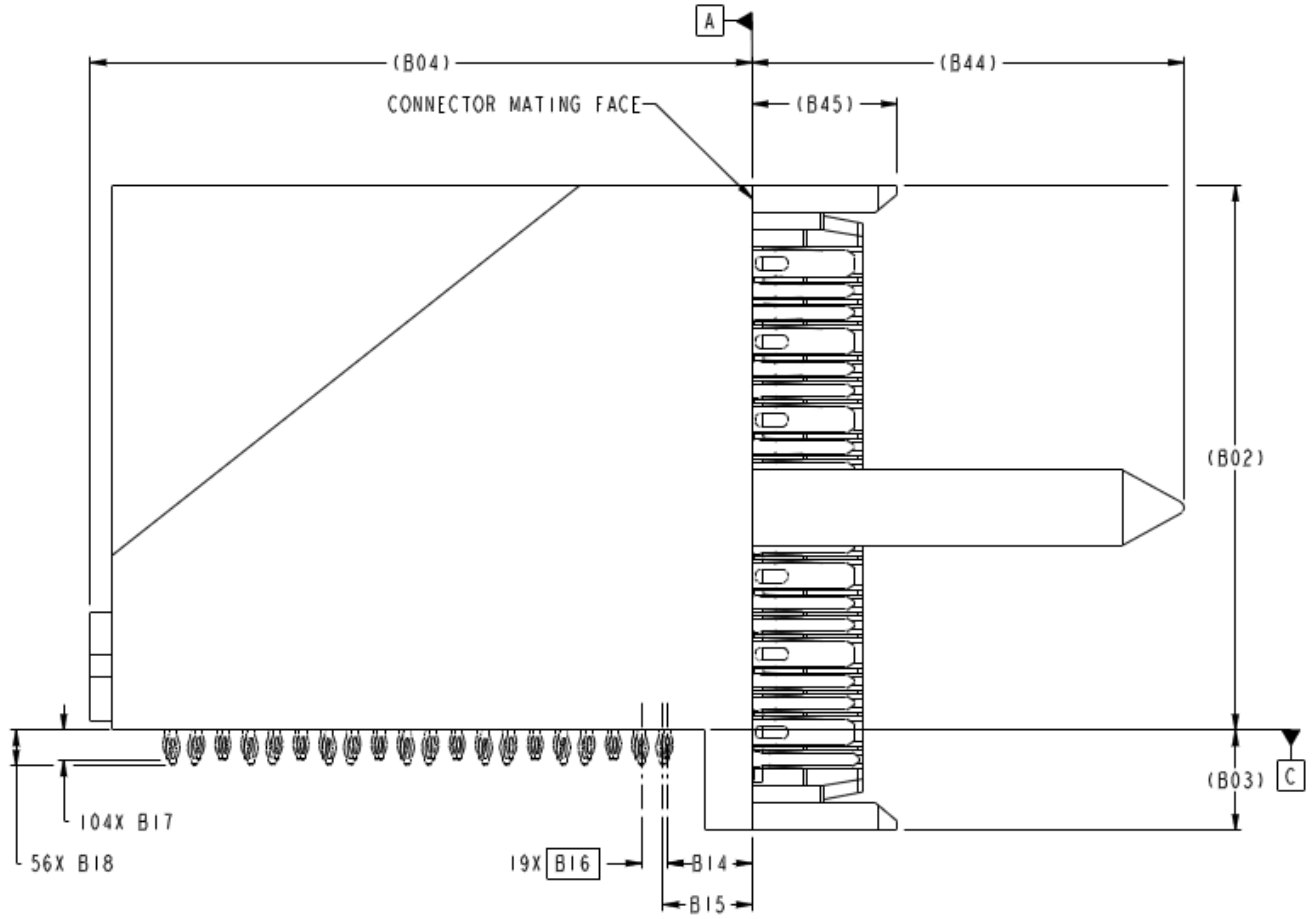

Figure 5-5 Right Angle Header Right Guidance Connector Side View

3  
4  
5  
6

1 **Table 5-3 Right Angle Header Right Guidance Connector Dimensions**

| Designator | Description                                       | Dimension(mm) | Tolerance +/- |
|------------|---|---------------|---------------|
| B01        | RAH connector width                               | 22.35         | +/-0.10       |
| B02        | RAH connector height from Datum C                 | 25.10         | Ref           |
| B03        | Height from Datum C to RAH housing bottom         | 4.60          | Ref           |
| B04        | RAH connector length from Datum A                 | 30.50         | Ref           |
| B05        | RAH guide pin center to Datum U                   | 11.2          | Basic         |
| B06        | RAH housing guide post width                      | 2.2           | +/-0.05       |
| B07        | Even column row A centers to first signal centers | 1.3           | Basic         |
| B08        | Ground centers                                    | 3.6           | Basic         |
| B09        | Signal pair centers                               | 1.0           | Basic         |
| B10        | Signal centers                                    | 3.6           | Basic         |
| B11        | Odd column row A centers to first ground centers  | 1.3           | Basic         |
| B12        | RAH guide pin center to housing bottom surface    | 14.85         | Basic         |
| B13        | RAH guide pin diameter                            | 3.45          | +/-0.05       |
| B14        | Datum A to centers of odd columns                 | 3.90          | +/-0.15       |
| B15        | Datum A to centers of even columns                | 4.10          | +/-0.15       |
| B16        | Pitch within each column                          | 1.20          | Basic         |
| B17        | Signals tail length                               | 1.40          | +/-0.20       |
| B18        | Grounds tail length                               | 1.60          | +/-0.20       |
| B19        | RAH housing guide key distance                    | 14.35         | +/-0.05       |
| B44        | RAH guide pin length from Datum A                 | 19.9          | +/-0.20       |
| B45        | RAH guide post length from Datum A                | 6.7           | +/-0.10       |

2  
3

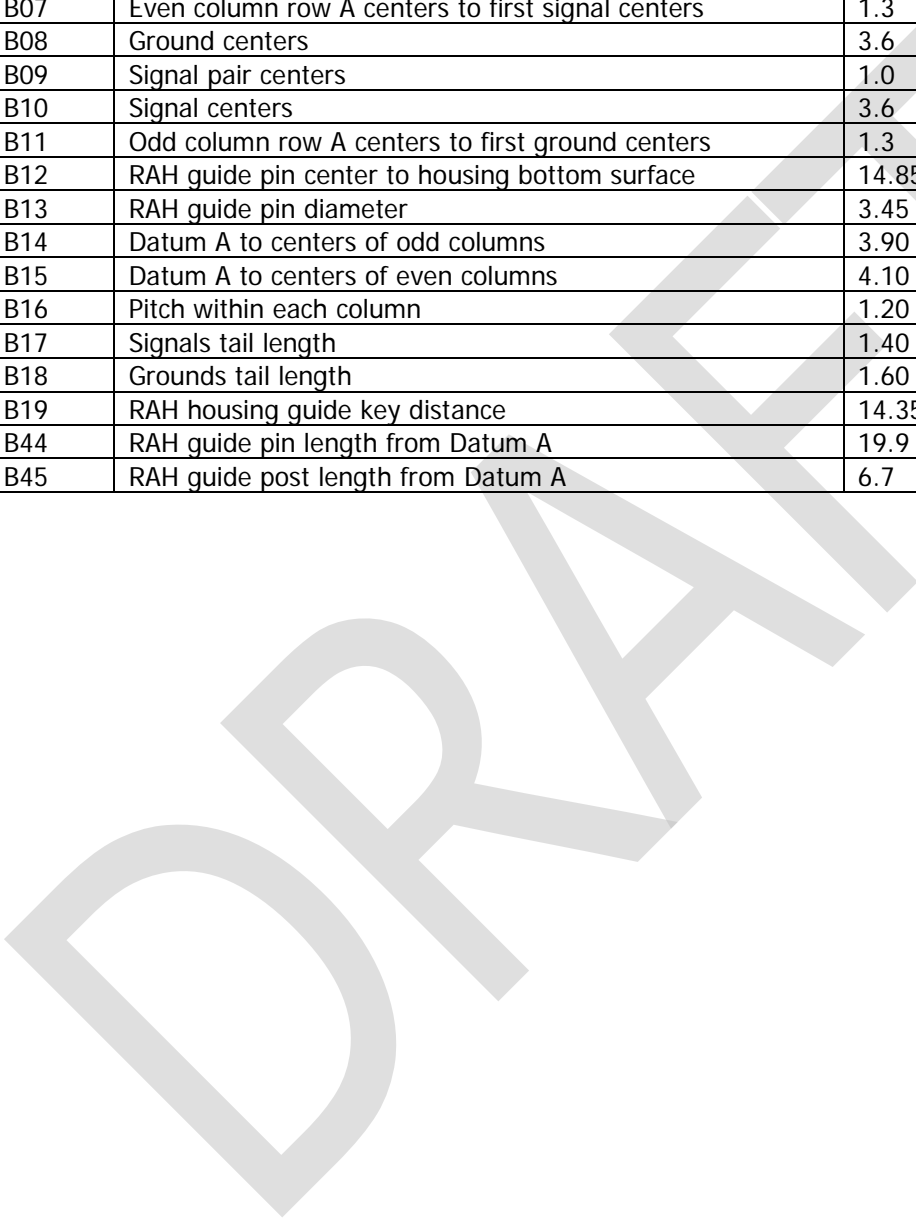

## 6. Performance Requirements

### 6.1 Performance Tables

EIA-364-1000 (TS-1000) shall be used to define the test sequences and procedures for evaluating the connector system described in this document. Where multiple test options are available, the manufacturer shall select the appropriate option where not previously specified. The selected procedure should be noted when reporting data. If there are conflicting requirements or test procedures between EIA-364 procedures and those contained within this document, this document shall be considered the prevailing authority.

Unless otherwise specified, procedures for sample size, data, and collection to be followed as specified in EIA-364-1000. See EIA-364-1000 Annex B for objectives of tests and test groups.

Table 6-1 summarizes the performance criteria that are to be satisfied by the connector described in this document. Most performance criteria are validated by EIA-364-1000 testing, but this test suite leaves some test details to be determined. To ensure that testing is repeatable, these details are identified in Table 6-2. Finally, testing procedures used to validate any performance criteria not included in EIA-364-1000 are provided in Table 6-3.

**Table 6-1 Form Factor Performance Requirements**

| Performance Parameters  | Description/ Details  | Requirement   |
|---|---|---|
| <b>Mechanical/ Physical Requirements</b>  |   |   |
| <b>Plating Type</b>   | Plating type on mating end of connector contacts  | Precious  |
| <b>Surface Treatment</b>  | Surface treatment on connector contacts   | Non-lubricated  |
| <b>Wipe length</b>  | Designed distance a contact traverses over a mating contact surface during mating and resting at a final position | Greater than 0.127mm (3.7mm for contact A1 and A7. 2.5mm for all others.) |
| <b>Rated Durability Cycles</b>  | The expected number of durability cycles a component is expected to encounter over the course of its life         | Right angle connector and mating header connector: 200 cycles             |
| <b>Environmental Requirements</b>   |   |   |
| <b>Field Life</b>   | The expected service life for a component   | 10 years  |
| <b>Field Temperature</b>  | The expected service temperature for a component  | 85°C  |
| <b>Storage Temperature*</b>   | The expected storage temperature for a component when not in use  | -55°C to +85°C  |
| <b>Storage Humidity*</b>  | The expected storage humidity for a component when not in use   | 10-75% Relative Humidity  |
| <b>Electrical Requirements</b>  |   |   |
| <b>Current*</b>   | Maximum current to which a contact is exposed in use  | 4A per contact MAX<br>See Table 6-4                                       |
| <b>Operating Rating Voltage</b>   | Maximum voltage to which a contact is exposed in use  | 30V DC per contact MAX  |
| NOTE: Performance criteria denoted with stars (*) are not validated by EIA-364-1000 testing. Refer to Table 6-3 for test procedures and pass/fail criteria. |   |   |

1 Table 6-2 describes the details necessary to perform the tests described in the EIA-364-1000 test sequences.  
 2 Testing shall be done in accordance with EIA-364-1000 and the test procedures it identifies in such a way that  
 3 the parameters/ requirements defined in Table 6-1 are met. Any information in this table supersedes EIA-364-  
 4 1000.

6 **Table 6-2 EIA-364-1000 Test Details**

| Test   | Test Descriptions and Details  | Pass/ Fail Criteria  |
|--|--|--|
| <b>Mechanical/ Physical Tests</b>  |  |  |
| <b>Durability (preconditioning)</b>  | EIA-364-09<br>To be tested with right angle connector and header connector only                                      | No evidence of physical damage   |
| <b>Durability (see Note 1)</b>   | EIA-364-09<br>To be tested with right angle connector and header connector only                                      | No visual damage to mating interface   |
| <b>Environmental Tests</b>   |  |  |
| <b>Mixed Flowing Gas (see Note 2)</b>  | EIA -364-65 Class IIA, 4-gas<br>See Table 4.1 in EIA-364-1000 for exposure times<br>Test option Per EIA-364-1000: 1B | No intermediate test criteria  |
| <b>Electrical Tests</b>  |  |  |
| <b>Low Level Contact Resistance (see Note 3)</b>   | EIA-364-23<br>20 mVDC MAX, 100 mA MAX<br>To include wire termination or connector-to-board termination               | 10 mΩ MAX change from baseline   |
| <b>Dielectric Withstanding Voltage</b>   | EIA-364-20<br>Method B<br>500 VDC minimum for 1 minute<br>Applied voltage may be product / application specific      | No defect or breakdown between adjacent contacts within a single column<br>-AND-<br>0.5 mA Max Leakage Current |
| <b>NOTES:</b>  |  |  |
| 1. If the durability requirement on the connector is greater than that of the module, modules may be replaced after their specified durability rating.<br>2. Test option, temperature, duration must be reported.<br>3. The first low level contact resistance reading in each test sequence is used to determine a baseline measurement. Subsequent measurements in each sequence are measured against this baseline. |  |  |

7  
8

1 Table 6-3 describes the testing procedures necessary to validate performance criteria not validated by EIA-364-  
 2 1000 testing. The tests must be performed in such a way that the parameters/ requirements defined in Table 6-1  
 3 are met.  
 4

5 **Table 6-3 Additional test Procedures**

| Test                              | Test Descriptions and Details  | Pass/ Fail Criteria  |
|-----------------------------------|--|--|
| <b>Mechanical/ Physical Tests</b> |  |  |
| <b>Mating Force</b>               | EIA-364-13<br>To be tested with connectors only, without any latching mechanism included   | The force to mate a receptacle connector and a corresponding header shall not exceed 0.45 N per contact. |
| <b>Unmating Force</b>             | EIA-364-13<br>To be tested with connectors only, without any latching mechanism included   | The un-mating force shall not be less than 0.10 N per contact.   |
| <b>Environmental Tests</b>        |  |  |
| <b>Storage Temperature</b>        | EIA-364-32<br>Method A, Test Condition 1, Duration 4<br>Use min and max Field Temperatures listed in Table 6-1 for temperature range | Refer to Table 6-1   |
| <b>Storage Humidity</b>           | EIA-364-31   | Refer to Table 6-1   |
| <b>Electrical Tests</b>           |  |  |
| <b>Current</b>                    | EIA-364-70<br>Method 3, 30-degree temperature rise<br>Contacts energized: See Table 6-4  | Refer to Table 6-1 and Table 6-4   |

6  
 7  
 8 **Table 6-4 Current Rating**

| Contacts Energized   | Contact Current Rating (amperes) |
|--|----------------------------------|
| Individual Signal Contact (centrally located in connector)   | 4                                |
| Single column, an insert molded leadframe assembly, or "wafer" (signal contacts carrying load, ground contacts carrying return)    | 17                               |
| Full adjacent columns, insert molded leadframe assemblies, or "wafers" (1 wafer carrying load, 2nd adjacent wafer carrying return) | 25                               |

1 **Appendix A: Recommended Right Angle Receptacle Connector**  
2 **Footprint (Informative)**

3 **A.1 Overview**

4 All material within this section, whether defined as normative or informative, is subject to IP disclosure and RAND  
5 terms by SNIA SFF TA TWG member companies

6 **A.2 Recommended Right Angle Receptacle Right Guidance Connector PCB Layout**

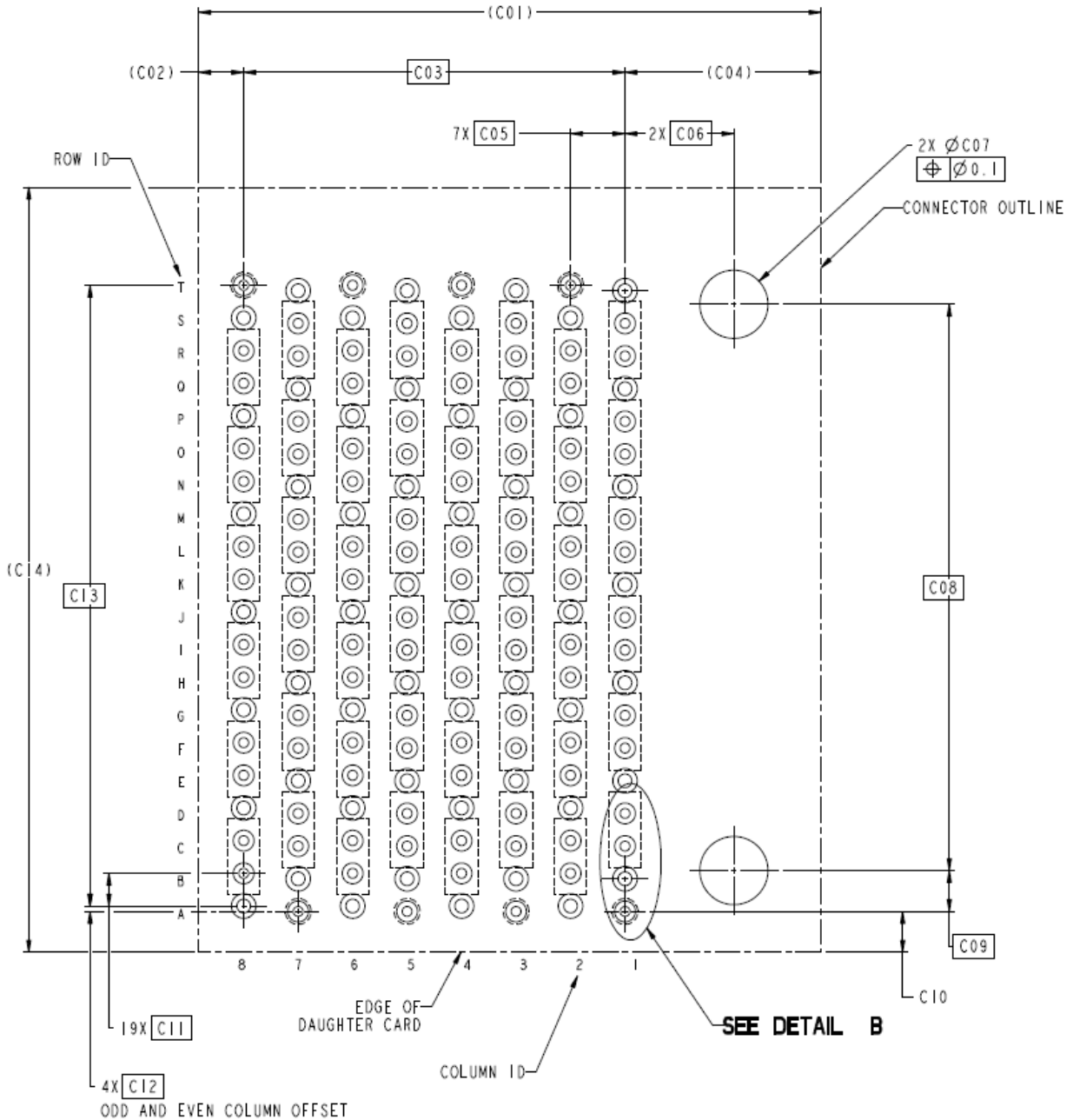

7 **Figure: A-1 Right Angle Receptacle Right Guidance Footprint**

8  
9



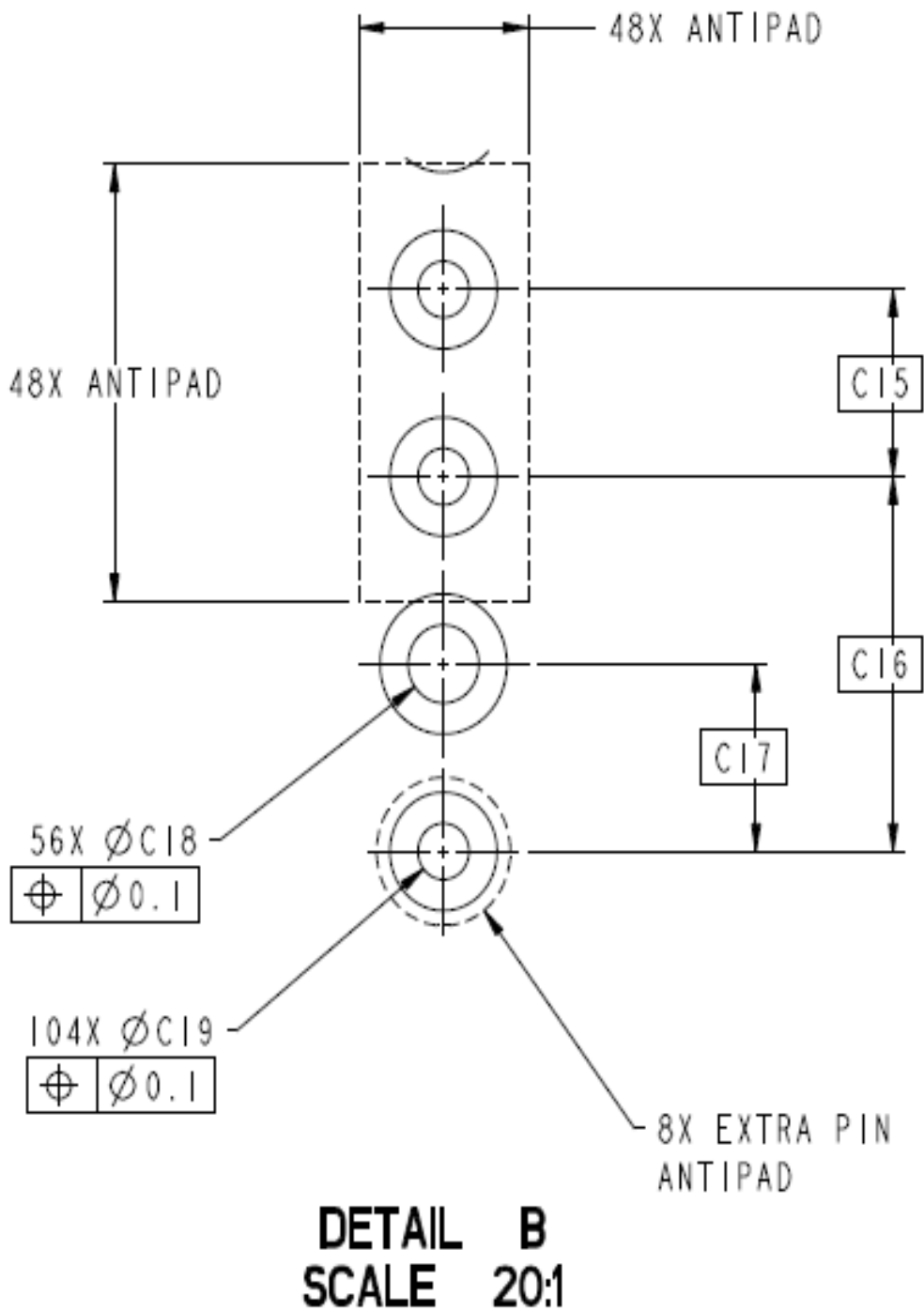

1  
2  
3

Figure: A-2 Right Angle Receptacle Right Guidance Connector Footprint - Detail View

1

**Table: A-1 Right Angle Receptacle Right Guidance Connector Footprint Dimensions**

| Designator | Description  | Dimension | Tolerance +/- |
|------------|--|-----------|---------------|
| C01        | RAR connector outline width                              | 22.85     | Ref           |
| C02        | Last row centers to connector edge                       | 1.65      | Ref           |
| C03        | Total column length                                      | 14.0      | Basic         |
| C04        | First row via centers to connector edge                  | 7.20      | Ref           |
| C05        | Column to column pitch                                   | 2.00      | Basic         |
| C06        | First row via centers to hold down locating hole centers | 4.00      | Basic         |
| C07        | Hold down locating hole diameter                         | 2.50      | +/-0.05       |
| C08        | Hold down locating hole distance                         | 20.8      | Basic         |
| C09        | A1 to hold down locating hole                            | 1.50      | Basic         |
| C10        | A1 to daughter card edge                                 | 1.50      | Max.          |
| C11        | Pitch within each column                                 | 1.20      | Basic         |
| C12        | Odd and even column offset                               | 0.20      | Basic         |
| C13        | Total pitch within each column                           | 22.80     | Basic         |
| C14        | RAR connector outline length                             | 28.10     | Ref           |
| C15        | Signal via pair pitch                                    | 1.20      | Basic         |
| C16        | Signal via pitch   | 2.40      | Basic         |
| C17        | Signal via to ground via                                 | 1.20      | Basic         |
| C18        | Ground via finish hole diameter                          | 0.500     | +/-0.05       |
| C19        | Signal via finish hole diameter                          | 0.360     | +/-0.05       |

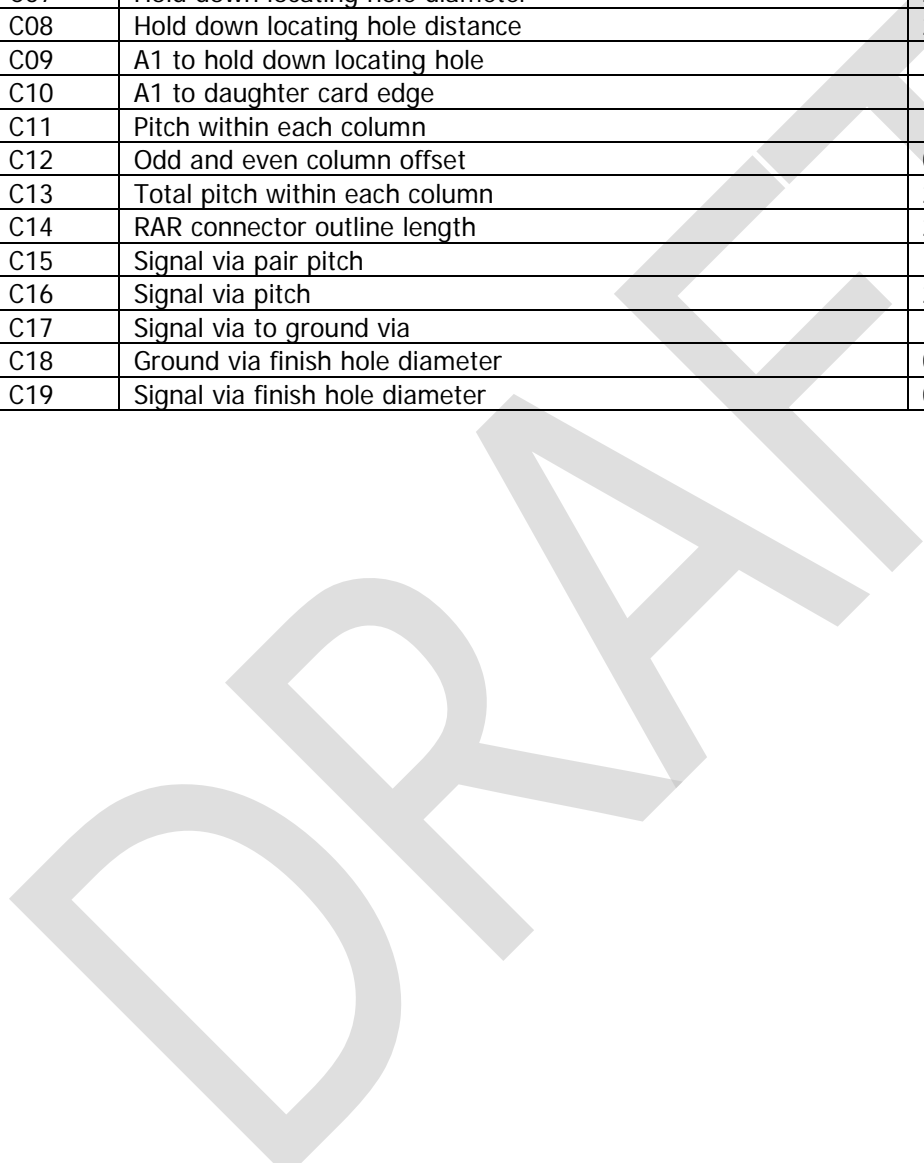

1 **A.3 Right Angle Receptacle Right Guidance Connector Attachment Screws**

2 It is recommended that two M2 pan head screws be used to attach integrated guide connectors to the PCB. In  
3 order to provide clearance for the fastener heads, it is important that no components or traces be within the  
4 cross hatched area shown. If the hold down or guide pin fastener hardware used has an outside diameter larger  
5 than 4.0mm then additional clearance will be required. See Figure: A-3  
6

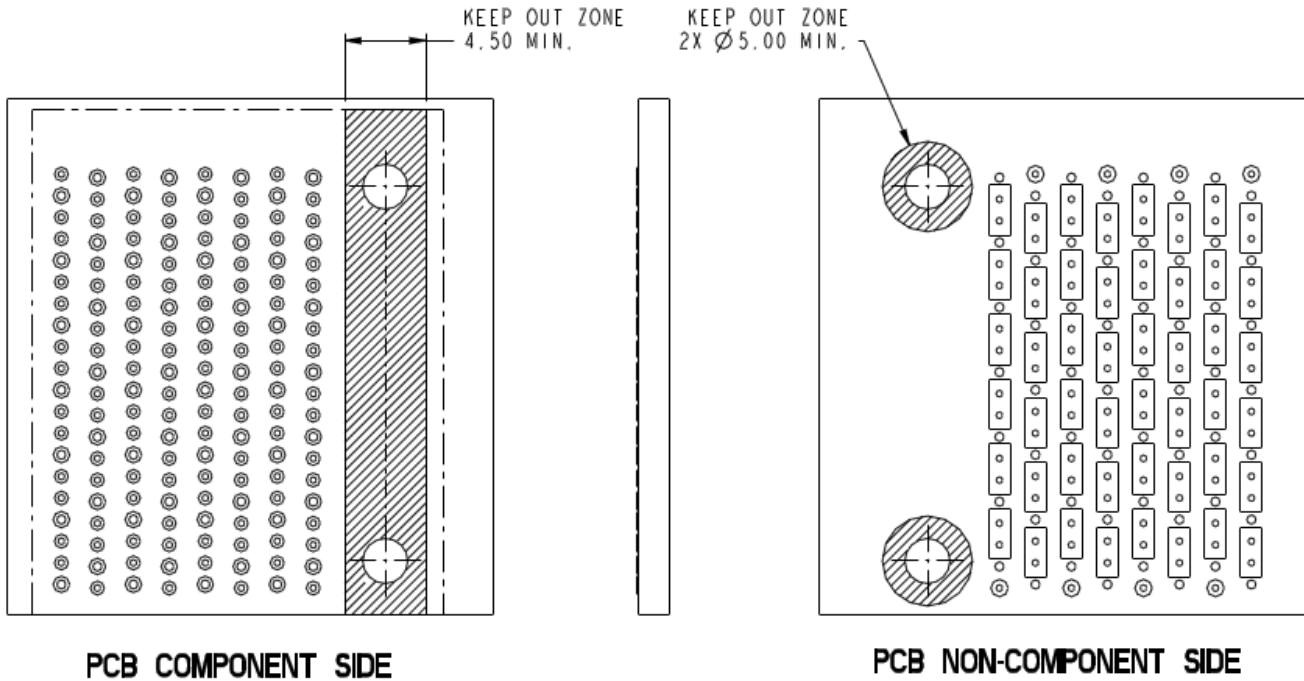

7  
8 **Figure: A-3 Keep Out Zone for Integrated Guide**  
9  
10  
11

1 **Appendix B: Recommended Right Angle Header Right Guidance**  
2 **Connector Footprint (Informative)**

3 **B.1 Overview**

4 All material within this section, whether defined as normative or informative, is subject to IP disclosure and RAND  
5 terms by SNIA SFF TA TWG member companies

6 **B.2 Recommended Right Angle Header Right Guidance Connector PCB Layout**  
7

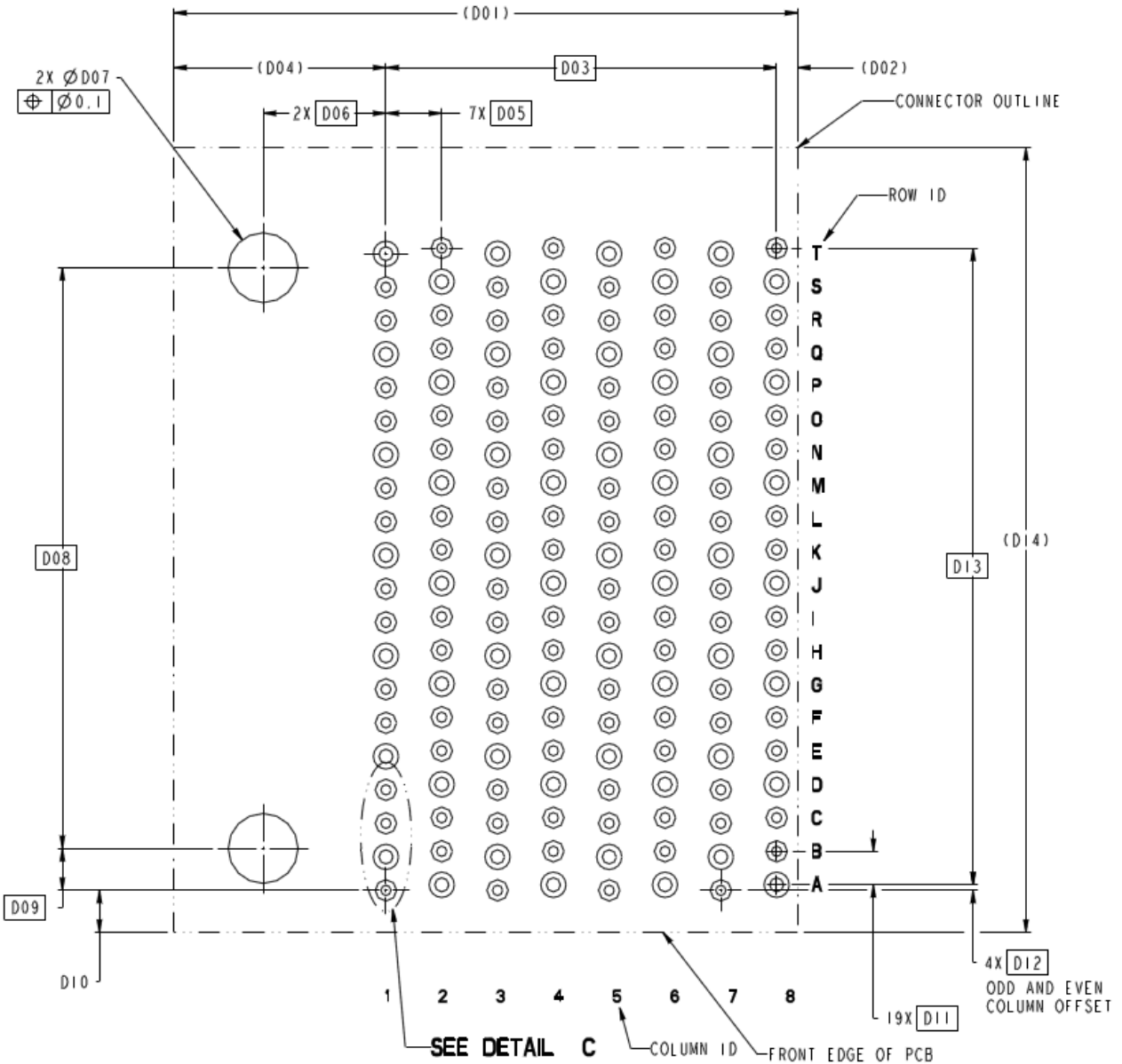

8 **Figure: B-1 Right Angle Header Right Guidance Footprint**  
9  
10

1

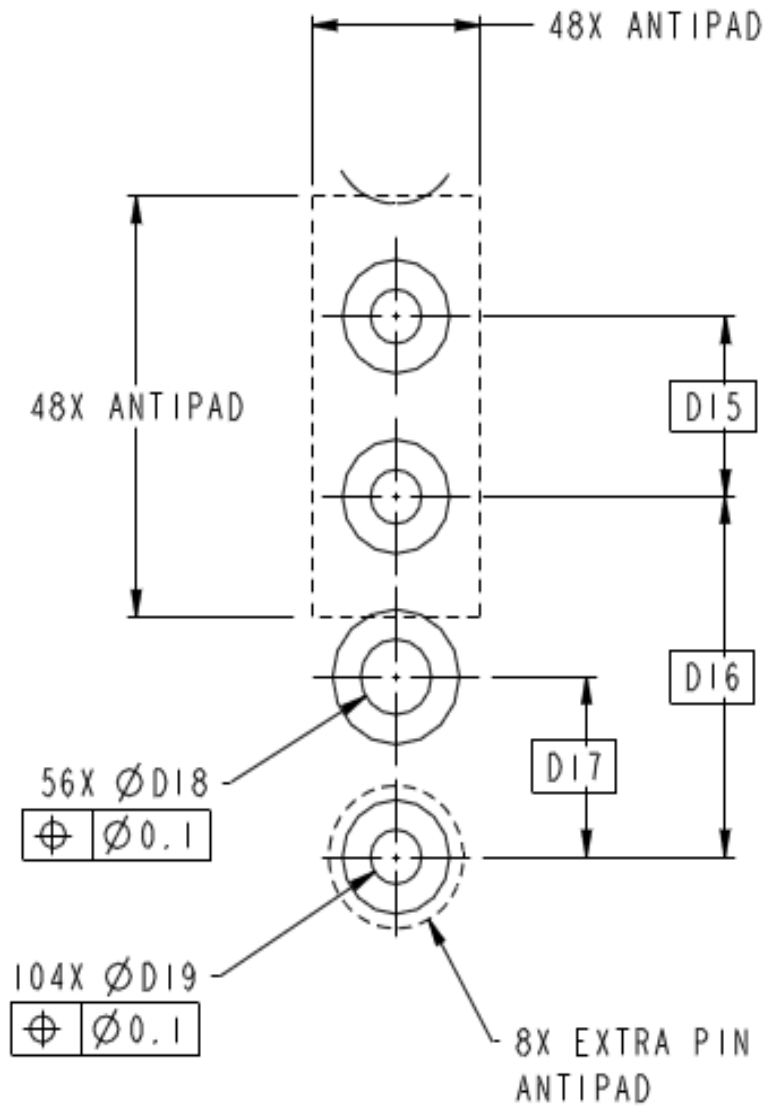

**DETAIL C**  
**SCALE 20:1**

2  
3  
4  
5

Figure: B-2 Right Angle Header Right Guidance Connector Footprint - Detail View

1

**Table: B-1 Right Angle Header Right Guidance Connector Footprint Dimensions**

| Designator | Description  | Dimension | Tolerance +/- |
|------------|--|-----------|---------------|
| D01        | RAH connector outline width                              | 22.35     | Ref           |
| D02        | Last row centers to connector edge                       | 0.75      | Ref           |
| D03        | Total column length                                      | 14.0      | Basic         |
| D04        | First row via centers to connector edge                  | 7.60      | Ref           |
| D05        | Column to column pitch                                   | 2.00      | Basic         |
| D06        | First row via centers to hold down locating hole centers | 4.40      | Basic         |
| D07        | Hold down locating hole diameter                         | 2.50      | +/-0.05       |
| D08        | Hold down locating hole distance                         | 20.8      | Basic         |
| D09        | A1 to hold down locating hole                            | 1.50      | Basic         |
| D10        | A1 to daughter card edge                                 | 1.50      | Max.          |
| D11        | Pitch within each column                                 | 1.20      | Basic         |
| D12        | Odd and even column offset                               | 0.20      | Basic         |
| D13        | Total pitch within each column                           | 22.80     | Basic         |
| D14        | RAR connector outline length                             | 28.10     | Ref           |
| D15        | Signal via pair pitch                                    | 1.20      | Basic         |
| D16        | Signal via pitch   | 2.40      | Basic         |
| D17        | Signal via to ground via                                 | 1.20      | Basic         |
| D18        | Ground via finish hole diameter                          | 0.500     | +/-0.05       |
| D19        | Signal via finish hole diameter                          | 0.360     | +/-0.05       |

DRAFT

1 **B.3 Right Angle Header Right Guidance Connector Attachment Screws**

2 It is recommended that two M2 pan head screws be used to attach integrated guide connectors to the PCB. In  
3 order to provide clearance for the fastener heads, it is important that no components or traces be within the  
4 cross hatched area shown. If the hold down or guide pin fastener hardware used has an outside diameter larger  
5 than 4.0mm then additional clearance will be required. See Figure: B-3  
6

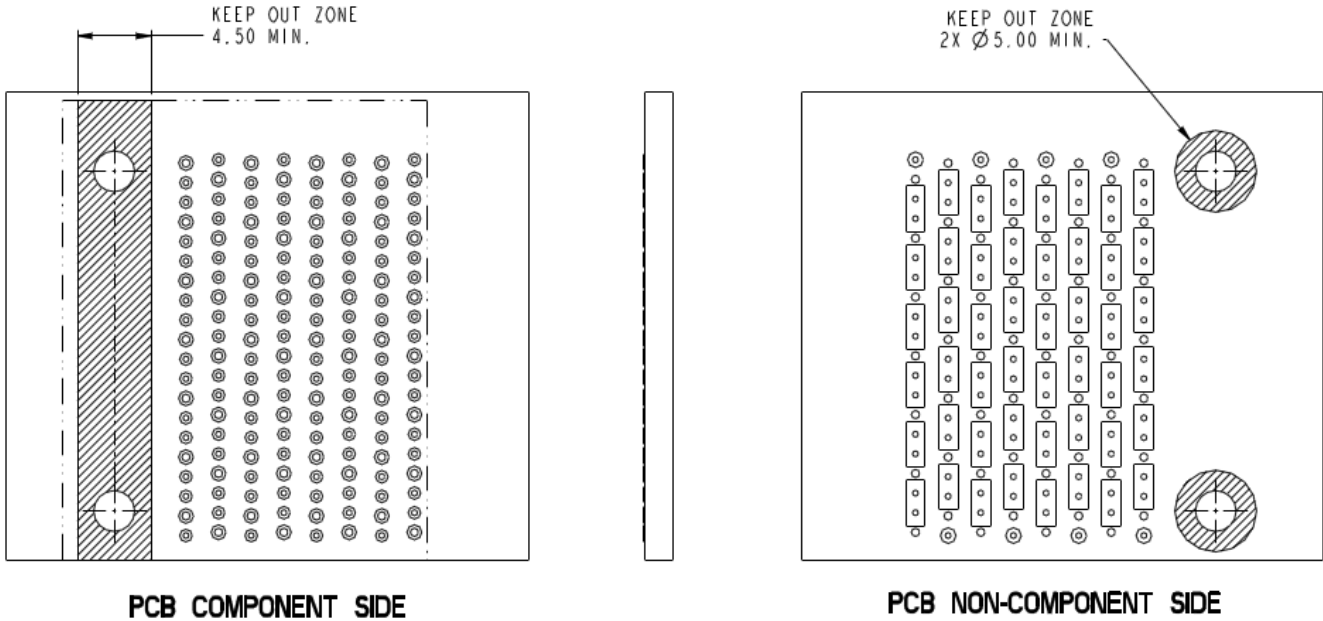

7  
8  
9

Figure: B-3 Keep Out Zone for Integrated Guide

DRAFT