

SFF specifications are available at <http://www.snia.org/sff/specifications>.



SFF-8611

Specification for

MiniLink 4/8X I/O Cable Assemblies

Rev 1.0

September 19, 2018

SECRETARIAT: SFF TA TWG

This specification is made available for public review at <http://www.snia.org/sff/specifications>. Comments may be submitted at <http://www.snia.org/feedback>. Comments received will be considered for inclusion in future revisions of this specification.

The description of a connector in this specification does not assure that the specific component is actually available from connector suppliers. If such a connector is supplied, it must comply with this specification to achieve interoperability between suppliers.

ABSTRACT: This specification defines the physical interface and general performance requirements for MiniLink free plugs and cable assemblies, which are designed for use in high speed serial, interconnect applications at multi-gigabit speeds. This specification provides information for the free plug and both internal and external cable assemblies. MiniLink receptacles provide the other half of the mating interface and are defined in SFF-8612.

POINTS OF CONTACT:

Alex Haser
Molex, LLC
2222 Wellington Ct
Lisle, IL 60532
Ph: 630-718-5418
Email: alex.haser@molex.com

Chairman SFF TA TWG
Email: SFF-Chair@snia.org

Intellectual Property

The user's attention is called to the possibility that implementation of this Specification may require the use of an invention covered by patent rights. By distribution of this specification, no position is taken with respect to the validity of a claim or claims or of any patent rights in connection therewith. This specification is considered SNIA Architecture and is covered by the SNIA IP Policy and as a result goes through a request for disclosure when it is published. Additional information can be found at the following locations:

- Results of IP Disclosures: <http://www.snia.org/sffdisclosures>
- SNIA IP Policy: <http://www.snia.org/ippolicy>

Change History

Rev 0.1

- First draft

Rev 0.2

- The speed characteristics and electrical considerations of SFF-8611 were removed to create SFF-8621.

Rev 0.3

- Added to the Abstract
- Added to the list of Industry documents
- Added notes 4 & 5 to 3.1
- Added contact function note to 4.1
- Replaced Figure 4-1, added Fig 4-2, Replaced Fig 5-1
- Added dimensions for the 8x to Table 5-1
- Revised 6-1 & 6-2 Figure and Table titles
- Added 8x dimensions to tables 6-1, 6-2, 6-4
- Revised dimensions and table notes for Tables 6-1, 6-2, 6-4
- Revised Figure 6-3 to clarify the fold and table description
- Corrected Figure & Table titles for 6-5 and 6-6
- Replaced Figure 6-7 and added the statement below the figure
- Revised the min/max numbers in Table 6-5

Rev 1.0 (September 19, 2018)

- Updated to SNIA format
- Reorganized content
- Corrected SFF-9000 in References to SFF-9400
- Updated SAS references in Section 2.1 and Section 2.2
- Updated definitions
- Updated drawings and dimension tables to match with other documentation in the industry and to add 8x interface
- Replaced Figure 4-1
- Replaced Figure 5-1 and added E18 to Table 5-1
- Updated performance & latching requirements
- Clarified wrenching requirements are only for external connectors/cables
- Minor editorial/ formatting changes

Foreword

The development work on this specification was done by the SNIA SFF TWG, an industry group. Since its formation as the SFF Committee in August 1990, the membership has included a mix of companies which are leaders across the industry.

When 2 1/2" diameter disk drives were introduced, there was no commonality on external dimensions e.g. physical size, mounting locations, connector type, connector location, between vendors. The SFF Committee provided a forum for system integrators and vendors to define the form factor of disk drives.

During their definition, other activities were suggested because participants in SFF faced more challenges than the form factors. In November 1992, the charter was expanded to address any issues of general interest and concern to the storage industry. The SFF Committee became a forum for resolving industry issues that are either not addressed by the standards process or need an immediate solution.

In July 2016, the SFF Committee transitioned to SNIA (Storage Networking Industry Association), as a TA (Technology Affiliate) TWG (Technical Work Group).

Industry consensus is not a requirement to publish a specification because it is recognized that in an emerging product area, there is room for more than one approach. By making the documentation on competing proposals available, an integrator can examine the alternatives available and select the product that is felt to be most suitable.

SFF meets during the T10 (see www.t10.org) and T11 (see www.t11.org) weeks, and SSWGs (Specific Subject Working Groups) are held at the convenience of the participants.

Many of the specifications developed by SFF have either been incorporated into standards or adopted as standards by ANSI, EIA, JEDEC and SAE.

For those who wish to participate in the activities of the SFF TWG, the signup for membership can be found at:

<http://www.snia.org/sff/join>

The complete list of SFF Specifications which have been completed or are currently being worked on by the SFF Committee is contained in the document SFF-8000 which can be found at:

<http://www.snia.org/sff/specifications>

Suggestions for improvement of this specification will be welcome, they should be submitted to:

<http://www.snia.org/feedback>

CONTENTS

1.	Scope	5
1.1	Application Specific Criteria	5
1.2	Copyright	5
1.3	Disclaimer	5
2.	References	6
2.1	Industry Documents	6
2.2	Sources	6
2.3	Conventions	6
2.4	Definitions	7
3.	General Description	8
4.	Contact Length Sequencing	9
5.	Free Plugs and Cable Assemblies	10
5.1	Free Plug Mating Interface	11
5.2	Internal Cable Assemblies	13
5.2.1	Straight Plug	14
5.2.2	Right-Angle Down (or Up) Plug	15
5.3	External Cable Assemblies	16
6.	Latching	17
6.1	Passive Latching	17
6.2	Active Latching	17
7.	Performance Requirements	18
7.1	EIA-364-1000 Test Details	19
7.2	Additional Test Details	20

FIGURES

Figure 2-1	Fixed Receptacle and Free Plug Definition	7
Figure 4-1	Contact Positions for 4x and 8x Free Plugs	9
Figure 4-2	Breakout Cable with One 8x Plug and Two 4x Plugs	10
Figure 5-1	Mating Interface for All Free Plugs	11
Figure 5-2	Internal Ribbon Cable Fold	13
Figure 5-3	Straight Plug For Internal Cable Assembly	14
Figure 5-4	Right-Angle Down Plug for Internal Cable Assembly	15
Figure 5-5	External Cable Assembly	16
Figure 6-1	Free Plug Passive Latch	17
Figure 6-2	Free Plug Active Latch	17

TABLES

Table 5-1	Free Plug Mating Interface Dimensions	12
Table 5-2	Internal Ribbon Cable Fold Dimensions	13
Table 5-3	Straight Plug For Internal Cable Assembly Dimensions	14
Table 5-4	Right-Angle Down Plug For Internal Cable Assembly Dimensions	15
Table 5-5	External Cable Assembly Dimensions	16
Table 6-1	Free Plug Passive Latch Dimensions	17
Table 6-2	Free Plug Active Latch Dimensions	17
Table 7-1	Performance Requirements	18
Table 7-2	EIA-364-1000 Test Details	19
Table 7-3	Additional Test Details	20

1. Scope

This specification defines the MiniLink cable plug, the mating interface, internal and external cable assemblies, latching criteria, and performance requirements.

1.1 Application Specific Criteria

This connector is capable of meeting the interface requirements for the internal I/O requirements of T10 SAS-4 and OCuLink 1.0.

1.2 Copyright

The SNIA hereby grants permission for individuals to use this document for personal use only, and for corporations and other business entities to use this document for internal use only (including internal copying, distribution, and display) provided that:

1. Any text, diagram, chart, table or definition reproduced shall be reproduced in its entirety with no alteration, and,
2. Any document, printed or electronic, in which material from this document (or any portion hereof) is reproduced shall acknowledge the SNIA copyright on that material, and shall credit the SNIA for granting permission for its reuse.

Other than as explicitly provided above, there may be no commercial use of this document, or sale of any part, or this entire document, or distribution of this document to third parties. All rights not explicitly granted are expressly reserved to SNIA.

Permission to use this document for purposes other than those enumerated (Exception) above may be requested by e-mailing copyright_request@snia.org. Please include the identity of the requesting individual and/or company and a brief description of the purpose, nature, and scope of the requested use. Permission for the Exception shall not be unreasonably withheld. It can be assumed permission is granted if the Exception request is not acknowledged within ten (10) business days of SNIA's receipt. Any denial of permission for the Exception shall include an explanation of such refusal.

1.3 Disclaimer

The information contained in this publication is subject to change without notice. The SNIA makes no warranty of any kind with regard to this specification, including, but not limited to, the implied warranties of merchantability and fitness for a particular purpose. The SNIA shall not be liable for errors contained herein or for incidental or consequential damages in connection with the furnishing, performance, or use of this specification.

Suggestions for revisions should be directed to <http://www.snia.org/feedback/>.

2. References

The SFF Committee activities support the requirements of the storage industry, and it is involved with several standards.

2.1 Industry Documents

- EIA 364	Electrical Connector/Socket Test Procedures
- ISO/IEC 14776-154	Serial Attached SCSI - 3 (SAS-3)
- ISO/IEC 14776-155	Serial Attached SCSI - 4 (SAS-4)
- IPC-A-610	Acceptability of Electronic Assemblies
- PCIe	OCuLink
- SFF-8410	HSS Copper Testing and Performance Requirements
- SFF-8436	Maximizing Card Edge Tolerances Technique
- SFF-8612	MiniLink 4/8X Shielded Connectors
- SFF-9400	Universal 4/8X Pinouts
- SFF-9402	Multi-Protocol Internal Cables for SAS and/or PCIe

2.2 Sources

Copies of Electronic Industries Alliance (EIA) standards may be purchased from the Electronic Components Industry Association (ECIA) (<https://www.ecianow.org>).

Copies of SAS standards may be purchased from the International Committee for Information Technology Standards (INCITS) (<http://www.incits.org>).

Copies of PCIe standards may be purchased from PCI-SIG (<http://pcisig.com>).

There are several projects active within the SFF TWG. The complete list of specifications which have been completed or are still being worked on is contained in the document SFF-8000 which can be found at <http://www.snia.org/sff/specifications>.

2.3 Conventions

The dimensioning conventions are described in ANSI-Y14.5M, Geometric Dimensioning and Tolerancing. All dimensions are in millimeters, which are the controlling dimensional units (if inches are supplied, they are for guidance only).

The ISO convention of numbering is used i.e., the thousands and higher multiples are separated by a space and a period is used as the decimal point. This is equivalent to the English/American convention of a comma and a period.

American	French	ISO
0.6	0,6	0.6
1,000	1 000	1 000
1,323,462.9	1 323 462,9	1 323 462.9

2.4 Definitions

For the purpose of SFF Specifications, the following definitions apply:

Connector: Two halves of an interface that when joined together, establish electrical contact and mechanical retention between two components. In this specification, the term “connector” does not apply to any specific gender; it can be used to describe the plug, the receptacle, or both. Other common terms include: connector interface, mating interface, and separable interface.

Contact length sequence: Order of electrical contact established/ terminated during mating/un-mating. Other terms include: contact sequencing, contact positioning, first mate/break last, early mate late break (EMLB), staggered contacts, and long pin / short pin.

Fixed: The stationary part of a connector interface. In this specification, “fixed” refers to the receptacle side.

Free: The removable part of a connector interface. In this specification, “free” refers to the plug side or cable assembly.

Offset: An alignment shift from the center line of the connector.

Optional: This term describes features which are not required by the SFF Specification. However, if any feature defined by an SFF Specification is implemented, it shall be done in the same way as defined by the Specification. Describing a feature as optional in the text is done to assist the reader.

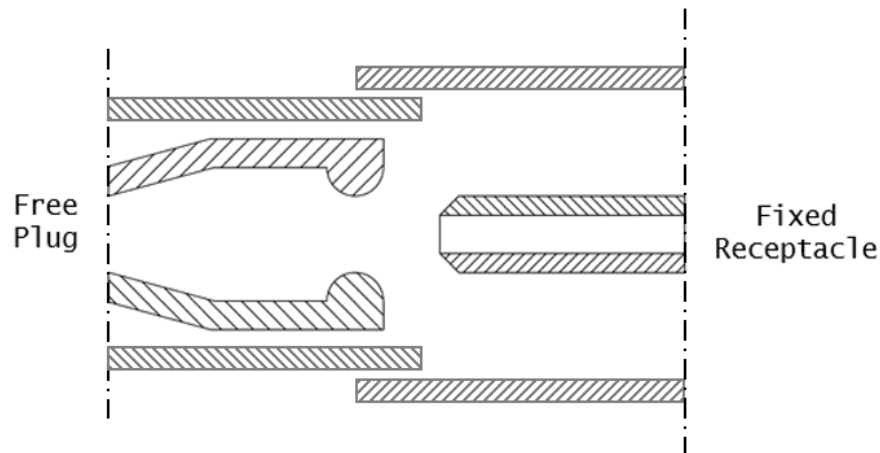

FIGURE 2-1 FIXED RECEPTACLE AND FREE PLUG DEFINITION

PCB: Printed circuit board

Plug: Used to describe the part of the connector that penetrates its mate upon mating, as shown in Figure 2-1. Other common terms include “male,” and “pin connector.”

Receptacle: Used to describe the part of the connector that accepts its mate upon mating, as shown in Figure 2-1. Other common terms include “female,” and “socket connector.”

Right Angle: A receptacle design where the mating direction is parallel to the printed circuit board upon which the receptacle is mounted OR a plug design where the mating direction is perpendicular to the bulk cable.

Straight: A plug design where the mating direction is parallel to the bulk cable.

Surface mount: A termination style in which pins do not penetrate the surface of a PCB. Pins sit on pads on the surface of a PCB and are then soldered to keep the connector and/or shell in place. Other common terms are “surface mount technology” or “SMT.”

Through hole: A termination style in which rigid pins penetrate the surface of a PCB. Pins typically must be soldered to keep the connector or shell in place. Other common terms are “plated through hole” or “PTH.”

Vertical: A receptacle design where the mating direction is perpendicular to the printed circuit board upon which the receptacle is mounted.

3. General Description

This connector system is based upon fixed receptacles (vertical and right-angle) and free plugs (straight and right-angle). It provides positive retention along with ease of insertion and removal. This specification provides the mechanical description and performance requirements for free plugs and cable assemblies. The same mechanical interface applies for both internal and external applications, but separate performance requirements are provided for both use cases. See SFF-8612 for information on fixed receptacles that provide the other half of the interface described here.

4. Contact Length Sequencing

Contact positions are shown in Figure 4-1 for 4X and 8X free plugs, respectively. All plug contacts shall be the same length (refer to Section 6). Contact length sequencing is established by staggered contacts on the fixed receptacle side of the connector interface; refer to SFF-8612 for details.

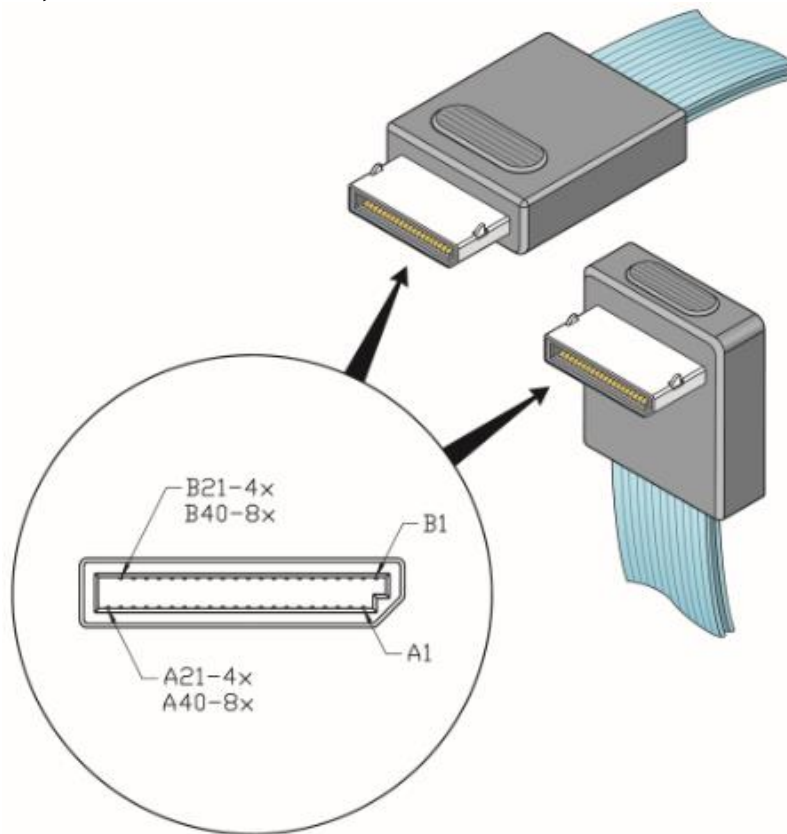

FIGURE 4-1 CONTACT POSITIONS FOR 4X AND 8X FREE PLUGS

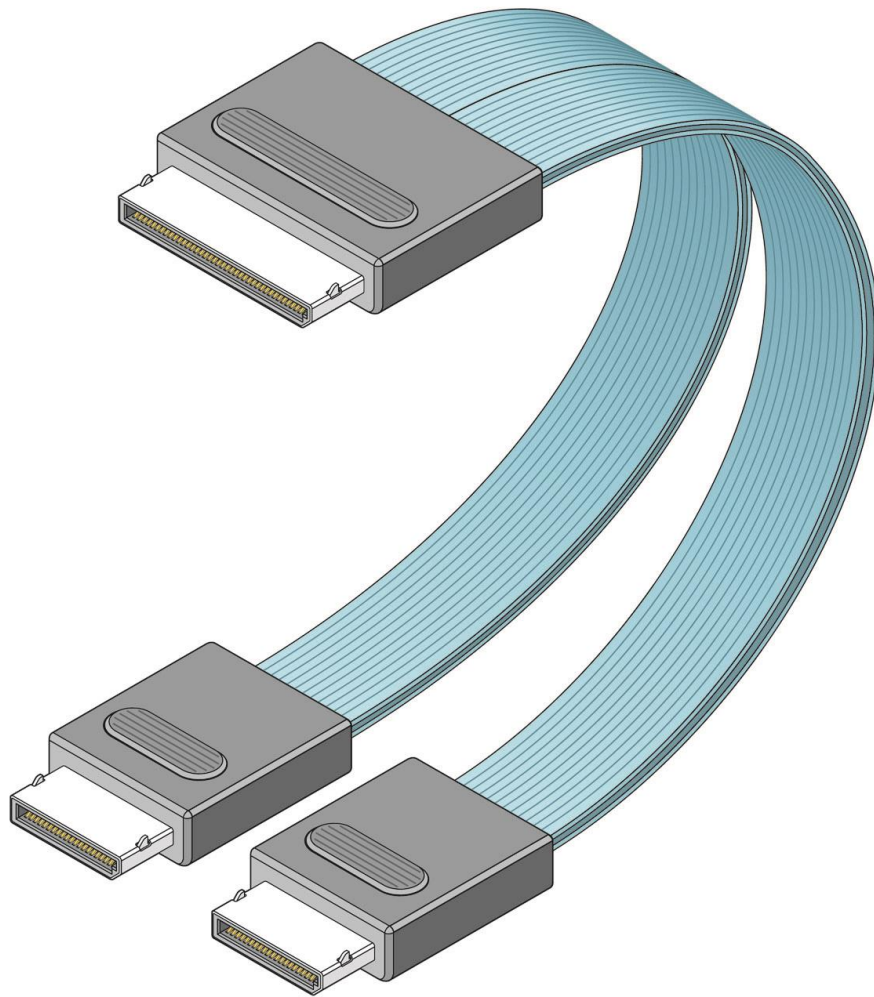

FIGURE 4-2 BREAKOUT CABLE WITH ONE 8X PLUG AND TWO 4X PLUGS

5. Free Plugs and Cable Assemblies

This specification provides the mechanical definitions for free plugs and cable assemblies. Plugs are available in both straight and right-angle variations for 4X and 8X circuit sizes. Cables may utilize passive or active latches, dimensions for which are provided in Table 6-1 and Table 6-2, respectively. Latch performance requirements are listed in Section 7.

Dual bundle, single bundle, and ribbon cable are all acceptable options for bulk cable if they meet all requirements defined by this specification. The way in which the bulk cable is attached to free plugs is not covered by this specification; it is left to the discretion of the supplier. Bulk cable may exit the plug in any direction.

In the case of breakout cables (e.g. one 8X plug on one end, two 4X plugs on the other), plug configurations and cable exits may be unique to each plug (e.g. straight plugs on the 8X and one 4X with a right angle plug on the remaining 4X).

5.1 Free Plug Mating Interface

The mating interface defined in this section is common for all free plugs, regardless of application or cable exit.

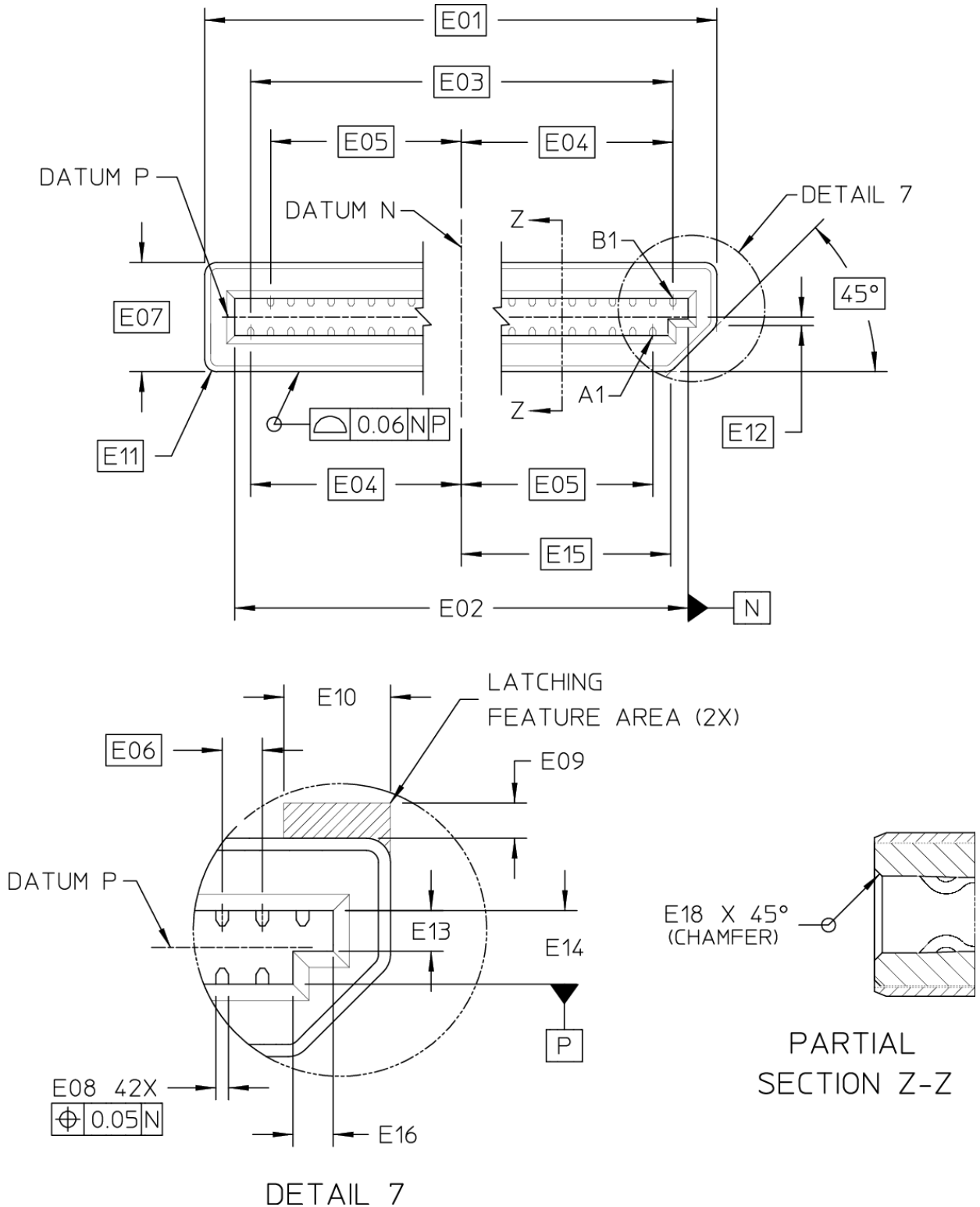

FIGURE 5-1 MATING INTERFACE FOR ALL FREE PLUGS

TABLE 5-1 FREE PLUG MATING INTERFACE DIMENSIONS

ID	Description	Dimension		Tolerance \pm
		4X	8X	
E01	Connector shell width	12.73	22.23	Basic
E02	Upper row interface width (Datum N)	11.28	20.78	0.03
E03	CL to CL of outside of contact beams	10.50	20.00	Basic
E04	Vertical CL of connector shell (Datum N) to CL outside contact beams	5.25	10.00	Basic
E05	Vertical CL of connector shell (Datum N) to CL of inside contact beams	4.75	9.50	Basic
E06	Contact beam pitch	0.50		Basic
E07	Connector shell height	2.72		Basic
E08	Contact beam width (42x)	0.16		0.03
E09	Latching mechanism height (2X)	0.48		MAX
E10	Latching mechanism width (2X)	1.10		MAX
E11	Outer radius of free connector shell (5X)	0.30		Basic
E12	CL interface cavity (Datum P) to outer sharp corner of shell (TSC)	0.17		Basic
E13	Polarizing notch height	0.67		0.03
E14	Interface cavity height (A side to B side) (Datum P)	1.23		0.05
E15	CL interface cavity (Datum N) to outer sharp corner of shell (TSC)	5.19	9.94	Basic
E16	Polarizing notch width	0.50		MAX
E18	Lead-in chamfer	0.20		MIN
Note: E17 is not included.				

5.2 Internal Cable Assemblies

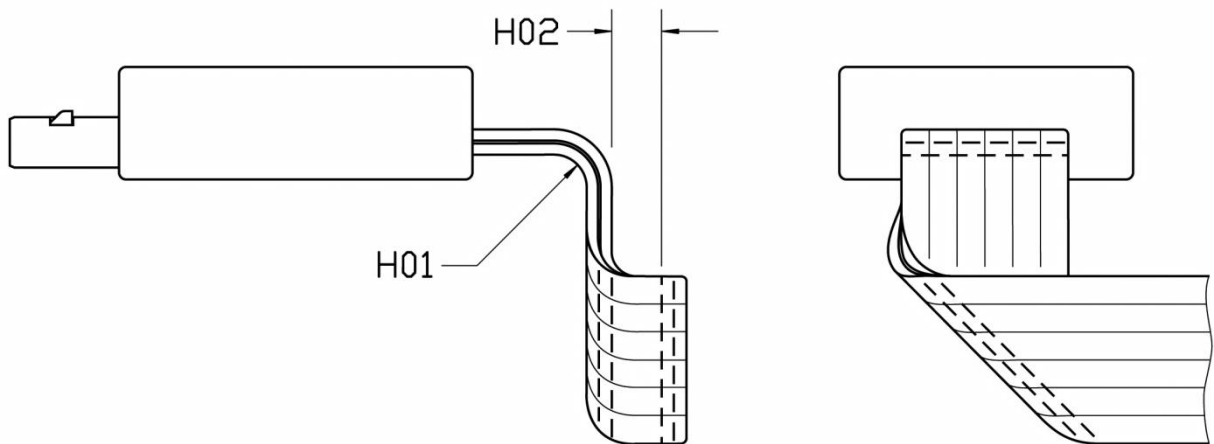

FIGURE 5-2 INTERNAL RIBBON CABLE FOLD

TABLE 5-2 INTERNAL RIBBON CABLE FOLD DIMENSIONS

ID	Description	Dimension		Tolerance ±
		4X	8X	
H01	Cable bend radius	MIN (see Note 1)		Supplier Specific
H02	Cable fold radius (see Note 2)	MIN (see Note 1)		Supplier Specific
NOTES:				
1. To be specified by supplier.				
2. Flat cable must not lay flat against itself when folded. Minimum fold radius is needed to preserve the properties of the insulator and therefore the signal integrity of the bulk cable.				

5.2.1 Straight Plug

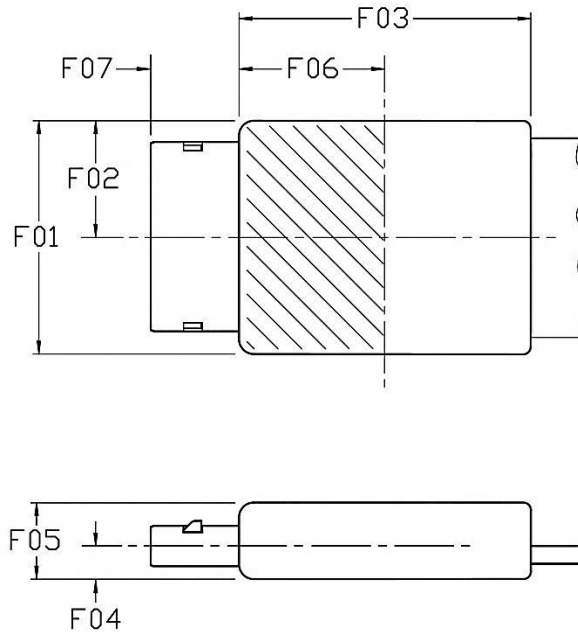

FIGURE 5-3 STRAIGHT PLUG FOR INTERNAL CABLE ASSEMBLY

TABLE 5-3 STRAIGHT PLUG FOR INTERNAL CABLE ASSEMBLY DIMENSIONS

ID	Description	Dimension		Tolerance ±
		4X	8X	
F01	Housing width (Note 1)	17.00	28.50	MAX
F02	CL to housing edge (Note 2)	8.50	14.25	MAX
F03	Housing length	20.00		MAX
F04	Connector CL to bottom of housing	2.20 (Note 3)		MAX
F05	Housing thickness	7.50		MAX
F06	Boundary for latch release (Note 4)	10.00		MAX
F07	Connector snout length	5.95		0.25

NOTES:

- Also applies to right-angle side-exit cable assemblies (not shown).
- CL of plug must align with CL of receptacle.
- Required for clearance when mated to a right-angle receptacle mounted mid-board.
- Refer to Section 6 for passive and active latch dimensions.

5.2.2 Right-Angle Down (or Up) Plug

NOTE: Right-angle side-exit cable assemblies must conform to the housing width defined in Section 5.2.1.

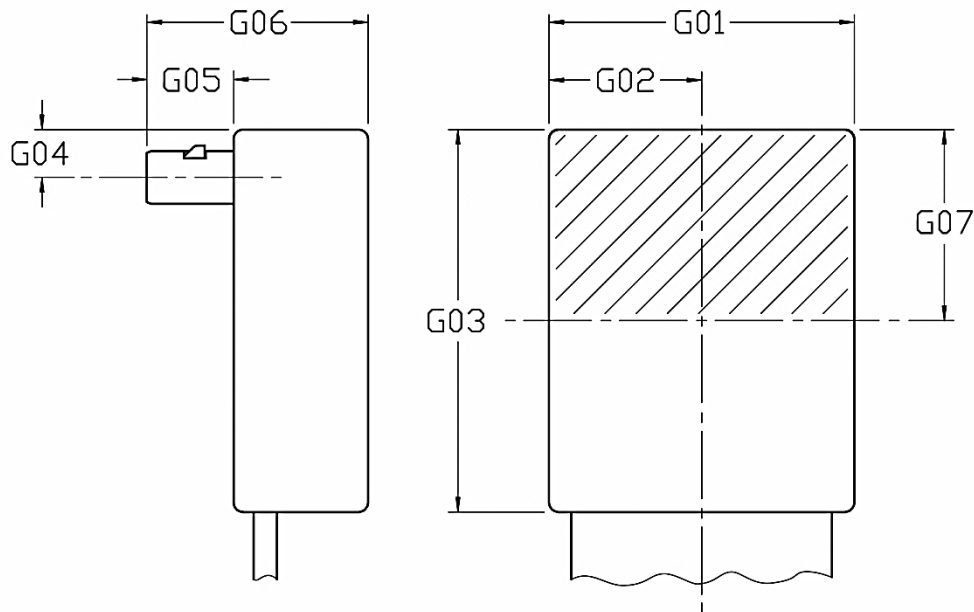

FIGURE 5-4 RIGHT-ANGLE DOWN PLUG FOR INTERNAL CABLE ASSEMBLY

TABLE 5-4 RIGHT-ANGLE DOWN PLUG FOR INTERNAL CABLE ASSEMBLY DIMENSIONS

ID	Description	Dimension		Tolerance ±
		4X	8X	
G01	Housing width	17.00	28.50	MAX
G02	CL of plug shell to housing edge (Note 1)	8.50	14.25	MAX
G03	Housing length	21.0		MAX
G04	CL of plug shell to bottom of housing	6.50		MAX
G05	Connector snout length	4.62		0.38
G06	Overall height of right-angle plug assembly	9.80 (Note 2)		MAX
G07	Boundary for latch release (Note 3)	10.50		MAX

NOTES:

1. CL of plug must align with CL of receptacle.
2. Enables mated height to remain below the maximum component height on a PCIe add-in card when mated with a vertical receptacle.
3. Refer to Section 6 for passive and active latch dimensions.

5.3 External Cable Assemblies

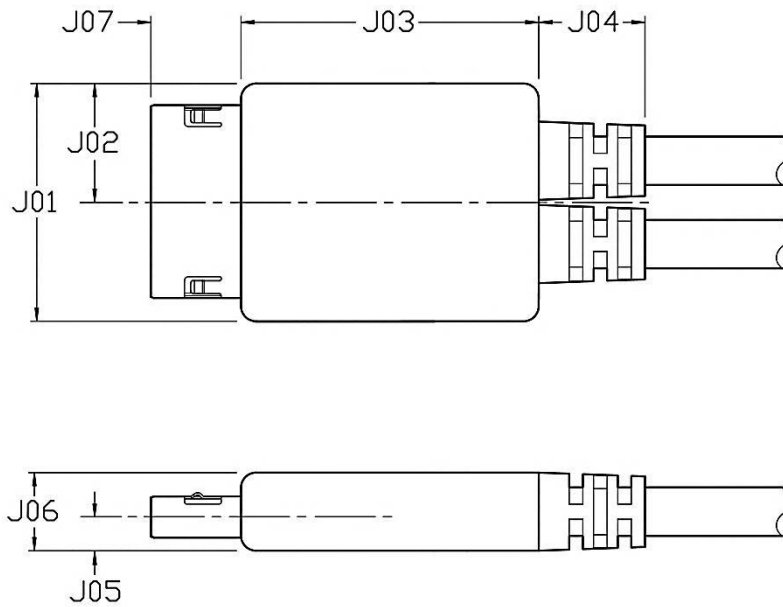

FIGURE 5-5 EXTERNAL CABLE ASSEMBLY

TABLE 5-5 EXTERNAL CABLE ASSEMBLY DIMENSIONS

ID	Description (Note 1)	Dimension		Tolerance ±
		4X	8X	
J01	Width of housing	17.00	28.50	MAX
J02	CL of housing to edge (Note 2)	8.50	14.25	MAX
J03	Housing length	25.00		MAX
J04	Length of flex relief (optional)	7.75		MAX
J05	CL of plug shell to bottom of housing (Note 2)	2.60		MAX
J06	Thickness of housing	7.50		MAX
J07	Connector snout length	5.95		0.25

NOTES:

1. Refer to Section 6 for passive and active latch dimensions.
2. CL of plug must align with CL of receptacle.
3. Enables belly-to-belly implementations on host boards that are sufficiently thick.

6. Latching

Free plugs and cable assemblies may utilize passive or active latches. Both latch styles must fit in the latch windows defined in SFF-8612.

6.1 Passive Latching

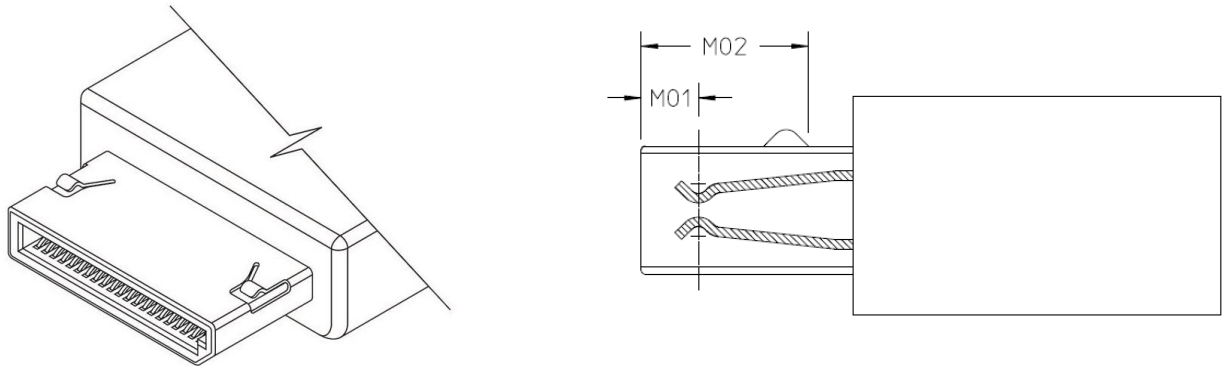

FIGURE 6-1 FREE PLUG PASSIVE LATCH

TABLE 6-1 FREE PLUG PASSIVE LATCH DIMENSIONS

ID	Description	Dimension	Tolerance \pm
M01	Front of connector to terminal contact point	1.14	0.10
M02	Front of connector to terminal passive latch retention point	3.49	0.20

6.2 Active Latching

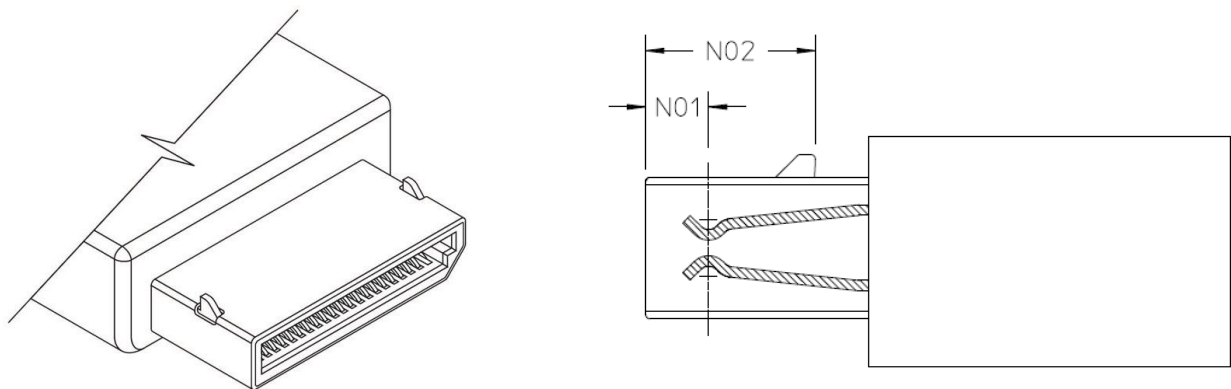

FIGURE 6-2 FREE PLUG ACTIVE LATCH

TABLE 6-2 FREE PLUG ACTIVE LATCH DIMENSIONS

ID	Description	Dimension	Tolerance \pm
N01	Front of connector to terminal contact point	1.14	0.10
N02	Front of connector to active latch retention point	3.34	0.14

7. Performance Requirements

All connectors defined in this specification must meet the performance requirements listed when mated. All performance requirements are verified by testing in accordance with EIA-364-1000 unless otherwise noted. Test details are summarized in subsequent sections.

TABLE 7-1 PERFORMANCE REQUIREMENTS

Parameter	Requirement
Mechanical/ Physical Requirements	
Noble Contact Plating Type	Manufacturer to specify
Contact Surface Treatment	Manufacturer to specify
Wipe Length	Greater than 0.127mm
Rated Durability Cycles	Internal: 250 cycles External (consumer): 10,000 cycles
Mating Force (see Notes 1 & 2)	4x: 25 N MAX 8x: 30 N MAX
Un-mating Force (see Notes 1 & 2)	4x: 25 N MAX 8x: 30 N MAX
Latch Retention Force (see Note 1)	30 N MIN
Wrench Force (see Notes 1 & 3)	7 N MIN
Environmental Requirements	
Field Life	5 years
Field Temperature	65 degrees C
Storage Temperature	-55 to 85 degrees C
Storage Humidity	85% relative humidity (see Note 4)
Electrical Requirements	
Current (see Note 1)	0.5 A per contact MAX 1.0 A per power contact MAX
Voltage (see Note 1)	30 VDC per contact MAX
NOTES:	
<ol style="list-style-type: none"> 1. These parameters are not evaluated as part of TS-1000. Refer to Section 7.2 for test method. 2. Un-mating force must be less than mating force. 3. Applies to external connectors and cables only. 4. At maximum storage temperature. 	

7.1 EIA-364-1000 Test Details

The details summarized in the following table are provided such that testing for the connector interface defined in this specification is done consistently. Details contained in this table take precedence over what is defined in EIA-364-1000.

TABLE 7-2 EIA-364-1000 TEST DETAILS

Test	Test Details	Pass/ Fail Criteria
Mechanical/ Physical Requirements		
Durability	Refer to Table 7-1 for minimum number or rated durability cycles. Latches may be disengaged during this test.	No pass/ fail criteria beyond TS-1000 required
Durability (preconditioning)		
Reseat		
Vibration	Follow TS-1000	
Environmental Requirements		
Cyclic Temperature and Humidity	Follow TS-1000	No pass/ fail criteria beyond TS-1000 required
Dust		
Mixed Flowing Gas	Option 2	
Temperature Life	Refer to Table 7-1 for minimum field life/ field temperature requirements.	
Temperature Life (preconditioning)		
Thermal Cycling		
Thermal Cycling (Disturbance)		
Thermal Shock (see Note 1)	Follow TS-1000	
Electrical Requirements		
Dielectric Withstanding Voltage	Method B 250 VDC for 100 ms	5 mA MAX leakage current
Low Level Contact Resistance	Follow TS-1000 (see Note 2)	20 mOhm MAX deviation from baseline (see Note 3)
NOTES:		
1. Storage temperature is dictated by the test method/ condition applied during this test.		
2. Any option may be used to measure low level contact resistance, but the same option must be used throughout the entire test sequence. Different options may be used for different sequences.		
3. There are no requirements on baseline measurements.		

7.2 Additional Test Details

Several performance requirements of the connector interface defined in this specification are beyond the scope of EIA-364-1000. The tests used to qualify these performance criteria are summarized in this section.

TABLE 7-3 ADDITIONAL TEST DETAILS

Test	Test Details	Pass/ Fail Criteria
Mechanical/ Physical Requirements		
Mating Force (see Note 1)	EIA-364-13 To be tested with cage, connector, and module or module analog	No visual damage to mating interface -AND- Peak force not to exceed maximum defined in Table 7-1.
Un-mating Force (see Note 2)		
Latch Retention Force	EIA-364-38 Method A Load greater than or equal to the latch force defined in Table 7-1.	No physical damage to connector interface and/or latching mechanism
Wrench Force (External cables only)	See Note 3	No physical damage to connector interface and/or latching mechanism -AND- No electrical discontinuity greater than 1 microsecond
Electrical Requirements		
Current	EIA-364-70 Method 3, 30-degree temperature rise	Refer to Table 7-1 for maximum value
Voltage	EIA-364-20 Annex A	
NOTES:		
<ol style="list-style-type: none"> 1. Latches must not be deactivated. 2. Latches must be disengaged before test starts -OR- include tension on tether as part of test. 3. The wrench force test is to be conducted as follows: mount receptacle connector to a board at least 0.8 mm thick. Clamp the board no further than 5mm away from the receptacle. Mate cable to be tested. Apply a load greater than or equal to the wrench force specified in Table 7-1 to the bulk cable no more than 12 inches away from the cable exit for 10 seconds. For round cables, apply force in 4 major axis directions perpendicular to the cable exit direction. For flat cables, apply force in two axis directions in the direction of the cable's minimum bend radius. 		