

SFF specifications are available at <http://www.snia.org/sff/specifications>  
or <ftp://ftp.seagate.com/sff>



SFF Committee

**SFF-8617**

Specification for

**Mini Multilane 12X Shielded Cage/Connector (CXP)**

Rev 1.7      September 14, 2016

Secretariat: SFF TA TWG

**Abstract:** This specification defines the physical interface and general performance requirements for the Mini Multilane Shielded Integrated Connector, which is designed for use in high speed serial, interconnect applications at multigigabit speeds such as InfiniBand and Ethernet.

This specification provides a common reference for systems manufacturers, system integrators, and suppliers.

This specification is made available for public review, and written comments are solicited from readers. Comments received by the members will be considered for inclusion in future revisions of this specification.

The description of a connector in this specification does not assure that the specific component is actually available from connector suppliers. If such a connector is supplied it must comply with this specification to achieve interoperability between suppliers.

**POINTS OF CONTACT:**

Jay Neer  
Technical Editor  
Molex  
2222 Wellington Court  
Lisle, IL 60532  
Ph: 561-447-2907 x555-3889  
Email: [jay.neer\\_at\\_molex\\_dot\\_com](mailto:jay.neer_at_molex_dot_com)

Chairman SFF TA TWG  
Email: [SFF-Chair@snia.org](mailto:SFF-Chair@snia.org)

The user's attention is called to the possibility that implementation to this Specification may require use of an invention covered by patent rights. By distribution of this specification, no position is taken with respect to the validity of a claim or claims or of any patent rights in connection therewith. Members of the SFF Committee which advise that a patent exists are required to provide a statement of willingness to grant a license under these rights on reasonable and non-discriminatory terms and conditions to applicants desiring to obtain such a license.

## **Change History**

The content of this specification was formerly contained in SFF-8647, and it was broken out into a separate specification so that it could be referenced by higher speed variations.

### **Rev 0.8**

- Editorial revision to adopt latest template
- Removed electrical performance requirements specified by the using interface

### **Rev 1.0**

- Simplified titling of sections, figures and tables.

### **Rev 1.1**

- Moved footprint to Appendix

### **Rev 1.2**

- Moved footprint back to body
- Harmonized with SFF-8642
- Replaced symbols with text

### **Rev 1.3**

- Upgraded many figures w/PNGs
- Updated dimensions in some tables

### **Rev 1.4**

- Title change for commonality in style with QSFP

### **Rev 1.5**

- This specification created with the connector content removed from SFF-8647

### **Rev 1.6**

- Changed A20 from 20.00 +/- 0.05 to 20.10 +/- 0.05
- Changed D23 from 19.89 +/- 0.05 to 19.94 +/- 0.08

### **Rev 1.7**

- A20 reverted from 20.10 +/- 0.05 to 20.00 +/- 0.05
- D23 reverted from 19.94 +/- 0.08 to 19.89 +/- 0.05

## Foreword

The development work on this specification done by the SFF Committee is being continued in the SNIA SFF TWG. Since its formation as the SFF Committee in August 1990, the membership has included a mix of companies which are leaders across the industry.

When 2 1/2" diameter disk drives were introduced, there was no commonality on external dimensions e.g. physical size, mounting locations, connector type, connector location, between vendors. The SFF Committee provided a forum for system integrators and vendors to define the form factor of disk drives.

During their definition, other activities were suggested because participants in SFF faced more challenges than the form factors. In November 1992, the charter was expanded to address any issues of general interest and concern to the storage industry. The SFF Committee became a forum for resolving industry issues that are either not addressed by the standards process or need an immediate solution.

In July 2016, the SFF Committee transitioned to SNIA (Storage Networking Industry Association), as a TA (Technology Affiliate) TWG (Technical Work Group).

Industry consensus is not a requirement to publish a specification because it is recognized that in an emerging product area, there is room for more than one approach. By making the documentation on competing proposals available, an integrator can examine the alternatives available and select the product that is felt to be most suitable.

SFF meets during the T10 (see [www.t10.org](http://www.t10.org)) and T11 (see [www.t11.org](http://www.t11.org)) weeks, and SSWG (Specific Subject Working Groups) are held at the convenience of the participants. Material presented to SFF becomes public domain, and there are no restrictions on the open mailing of the presented material by Members.

Many of the specifications developed by SFF have either been incorporated into standards or adopted as standards by ANSI, EIA, JEDEC and SAE.

For those who wish to participate in the activities of the SFF TWG, the signup for membership can be found at:

<http://www.snia.org/sff/join>

The complete list of SFF Specifications which have been completed or are currently being worked on by the SFF Committee can be found at:

<http://www.snia.org/sff/specifications>

Suggestions for improvement of this specification will be welcome, they should be submitted to:

<http://www.snia.org/feedback>

## TABLE OF CONTENTS

1	Scope	6
1.1	Copyright	6
1.2	Disclaimer	6
2	References	6
2.1	Industry Documents	6
2.2	Sources	6
2.3	Conventions	7
2.4	Definitions	7
3	General Description	9
4	Datums	10
5	Shielded Connector Dimensional Requirements	11
5.1	Plug Paddle Card	11
5.2	Free (Plug) Cable Connector	13
5.3	Free (Plug) Cable Connector Pull Tab	17
5.4	Fixed (Receptacle) Right Angle Connector	18
5.5	Fixed (Receptacle) Right Angle Connector Footprint	22
5.6	Fixed (Receptacle) Right Angle Connector Ground Pad	24
5.7	Fixed (Receptacle) Right Angle Connector Panel Cutout	25
5.8	Minimum Spacing For Receptacles	25
5.9	Orientation Key	26
5.10	Thermal Solution	27
5.11	Thermal Interface Definition for Plug on Plug	28
5.12	Heat Sink Configuration	29
5.13	Heat Sink Clip	30
5.14	Heat Sink Attach Points on Receptacle	31
5.15	Dust Cover for Receptacle Ports	32
6	Performance Requirements	33

## FIGURES

Figure 2-1	Mating side Gender Definition	8
Figure 3-1	General View of a Shielded Integrated Connector	9
Figure 4-1	Definition of Datums	10
Figure 5-1	Plug Paddle Card	11
Figure 5-2	Plug (1)	13
Figure 5-3	Plug (2)	14
Figure 5-4	Plug (3)	15
Figure 5-5	Plug (4)	16
Figure 5-6	Plug Pull Tab Example	17
Figure 5-7	Receptacle (1)	18
Figure 5-8	Receptacle (2)	19
Figure 5-9	Receptacle (3)	20
Figure 5-10	Receptacle Footprint	22
Figure 5-11	Receptacle Ground Pad	24
Figure 5-12	Receptacle Panel Cutout	25
Figure 5-13	Minimum Port Spacing - Horizontal and Vertical Pitch	25
Figure 5-14	Orientation Key	26
Figure 5-15	Receptacle with Optional Spring-loaded Heat Sink and Clip	27
Figure 5-16	Thermal Interface Definition for Plug	28
Figure 5-17	Heat Sink Thermal Interface Profile for Receptacle	29
Figure 5-18	Heat Sink Clip	30
Figure 5-19	Heat Sink Attach Points	31
Figure 5-20	Dust Cover for Receptacle Ports	32

## TABLES

Table 4-1 Definition of Datums	10
Table 5-1 Plug Paddle Card Dimensions	12
Table 5-2 Plug Dimensions	16
Table 5-3 Plug Pull Tab Example Dimensions	17
Table 5-4 Receptacle Dimensions	21
Table 5-5 Receptacle Footprint Dimensions	23
Table 5-6 Receptacle Ground Pad Dimensions	24
Table 5-7 Receptacle Panel Cutout Dimensions	25
Table 5-8 Minimum Port Spacing Dimensions	25
Table 5-9 Orientation Key/Keyway Dimensions	27
Table 5-10 Thermal Interface Definition for Plug	28
Table 5-11 Heat Sink Thermal Interface Dimensions	29
Table 5-12 Heat Sink Clip Dimensions	30
Table 5-13 Heat Sink Attach Points Dimensions	31
Table 5-14 Dust Cover for Receptacle Ports Dimensions	32
Table 6-1 TS-1000 Requirements	33
Table 6-2 Electrical Requirements	33
Table 6-3 Mechanical Requirements	33
Table 6-4 Environmental Requirements	33

## 1 Scope

This specification defines the plug, guide/strain relief shell, and latching requirements for the Mini Multilane Shielded Integrated Connector based upon the mating interface defined herein.

### 1.1 Copyright

The SNIA hereby grants permission for individuals to use this document for personal use only, and for corporations and other business entities to use this document for internal use only (including internal copying, distribution, and display) provided that:

1. Any text, diagram, chart, table or definition reproduced shall be reproduced in its entirety with no alteration, and,
2. Any document, printed or electronic, in which material from this document (or any portion hereof) is reproduced shall acknowledge the SNIA copyright on that material, and shall credit the SNIA for granting permission for its reuse.

Other than as explicitly provided above, there may be no commercial use of this document, or sale of any part, or this entire document, or distribution of this document to third parties. All rights not explicitly granted are expressly reserved to SNIA.

Permission to use this document for purposes other than those enumerated (Exception) above may be requested by e-mailing [copyright\\_request@snia.org](mailto:copyright_request@snia.org). Please include the identity of the requesting individual and/or company and a brief description of the purpose, nature, and scope of the requested use. Permission for the Exception shall not be unreasonably withheld. It can be assumed permission is granted if the Exception request is not acknowledged within ten (10) business days of SNIA's receipt. Any denial of permission for the Exception shall include an explanation of such refusal.

### 1.2 Disclaimer

The information contained in this publication is subject to change without notice. The SNIA makes no warranty of any kind with regard to this specification, including, but not limited to, the implied warranties of merchantability and fitness for a particular purpose. The SNIA shall not be liable for errors contained herein or for incidental or consequential damages in connection with the furnishing, performance, or use of this specification.

Suggestions for revisions should be directed to <http://www.snia.org/feedback/>

## 2 References

### 2.1 Industry Documents

The following interface standards are relevant to many SFF Specifications.

- EIA-364 Test Procedures
- SFF-8410 High Speed Serial Testing for Copper Links
- SFF-8647 Mini Multilane 14 Gb/s 12X Shielded Cage/Connector (CXP14)
- SFF-8648 Mini Multilane 28 Gb/s 12X Shielded Cage/Connector (CXP28)

### 2.2 Sources

There are several projects active within the SFF TWG, and all specifications are available at [www.snia.org/sff/specifications](http://www.snia.org/sff/specifications)

Copies of ANSI standards may be purchased from the InterNational Committee for Information Technology Standards (<http://www.techstreet.com/incitsgate.tmpl>).

### 2.3 Conventions

The dimensioning conventions are described in ANSI-Y14.5M, Geometric Dimensioning and Tolerancing. All dimensions are in millimeters.

The ISO convention of numbering is used i.e., the thousands and higher multiples are separated by a space and a period is used as the decimal point. This is equivalent to the English/American convention of a comma and a period.

American	French	ISO
0.6	0,6	0.6
1,000	1 000	1 000
1,323,462.9	1 323 462,9	1 323 462.9

### 2.4 Definitions

For the purpose of SFF Specifications, the following definitions apply:

**Advanced grounding contacts:** Connector contacts that make first and break last and are capable of carrying power ground return currents and performing electrostatic discharge. Other terms sometimes used to describe these features are: grounding pins, ESD contacts, grounding contacts, static drain, and pre-grounding contacts.

**Board Termination Technologies:** Surface mount single row, surface mount dual row, through hole, hybrid, straddle mount, pressfit.

**Cable Termination:** The attachment of wires to the termination side of a connector. Schemes commonly used in the industry are IDC (Insulation Displacement Contact), IDT (Insulation Displacement Termination), wire slots, solder, weld, crimp, braise, etc.

**Contact mating sequence:** Order of electrical contact during mating/unmating process. Other terms sometimes used to describe this feature are: contact sequencing, contact positioning, make first/break last, EMLB (early make late break) staggered contacts, and long pin / short pin.

**Fixed:** Used to describe the gender of the mating side of the connector that accepts its mate upon mating. This gender is frequently, but not always, associated with the common terminology "receptacle". Other terms commonly used are "female" and "socket connector". The term "fixed" is adopted from EIA standard terminology as the gender that most commonly exists on the fixed end of a connection, for example, on the board or bulkhead side. In this specification "fixed" is specifically used to describe the mating side gender illustrated in Figure 2-1.

**Fixed Board:** A connector that uses a fixed gender mating side and a termination side suitable for any of the printed circuit board termination technologies.

**Free:** Used to describe the gender of the mating side of the connector that penetrates its mate upon mating. This gender is frequently, but not always, associated with the common terminology "plug". Other terms commonly used are "male" and "pin connector". The term "free" is adopted from EIA standard terminology as the gender that most commonly exists on the free end of a connection, for example, on the cable side. In this specification "free" is specifically used to describe the mating side gender illustrated in Figure 2-1.

**Free Board:** A connector that uses a free gender mating side and a termination side suitable for any of the printed circuit board termination technologies

**Frontshell:** That metallic part of a connector body that directly contacts the backshell or other shielding material that provides mechanical and shielding continuity between the connector and the cable media. Other terms sometimes used to describe this part of a cable assembly are: housing, nosepiece, cowling, and metal shroud.

**Height:** Distance from board surface to farthest overall connector feature

**Mating side:** The side of the connector that joins and separates from the mating side of a connector of opposite gender. Other terms commonly used in the industry are mating interface, separable interface and mating face.

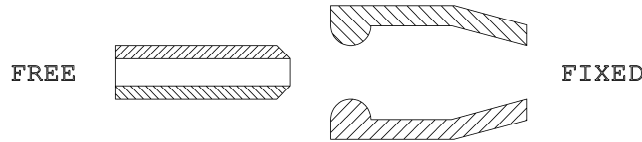

Note: The fixed gender is used on the device side except in the case of wire termination.

**FIGURE 2-1 MATING SIDE GENDER DEFINITION**

**Offset:** An alignment shift from the center line of the connector

**Optional:** This term describes features which are not required by the SFF Specification. However, if any feature defined by the SFF Specification is implemented, it shall be done in the same way as defined by the Specification. Describing a feature as optional in the text is done to assist the reader. If there is a conflict between text and tables on a feature described as optional, the table shall be accepted as being correct.

**Press-fit:** The connector's press-fit pins are pressed into the plated through holes in the PCB by applying mechanical force. The pins are sized to deform to create a lasting gas-tight electrical connection between the press-fit pin and the metalized hole. The press-fit pins ensure the mechanical stability and the electrical contact.

**Right Angle:** A connector design for use with printed circuit board assembly technology where the mating direction is parallel to the plane of the printed circuit board

**Straight:** A connector design for use with printed circuit board assembly technology where the mating direction is perpendicular to the plane of the printed circuit board.

**Surface Mount:** A connector design and a printed circuit board design style where the connector termination points do not penetrate the printed circuit board and are subsequently soldered to the printed circuit board.

**Termination side:** The side of the connector opposite the mating side that is used for permanently attaching conductors to the connector. Due to pin numbering differences between mating side genders the termination side shall always be specified in conjunction with a mating side of a specific gender. Other terms commonly used in the industry are: back end, non-mating side, footprint, pc board side, and post side

**Through hole:** A connector design and a printed circuit board design style where the connector termination points penetrates the printed circuit board and are subsequently soldered to the printed circuit board.



### 3 General Description

The connector system is based upon a shielded integrated receptacle connector and guide shell. The host board footprint positioning holes contain the critical dimensions for locating the integrated receptacle pins and guide shell. The receptacle guide shell functions as the guide and strain relief for the free (plug) connector interface. This connector system provides positive retention along with ease of insertion and removal.

The configuration defined in this specification is an integrated right angle 84 position host board receptacle and it's mating cable plug connector.

Figure 3-1 illustrates an example of one configuration of a Shielded Integrated Connector.

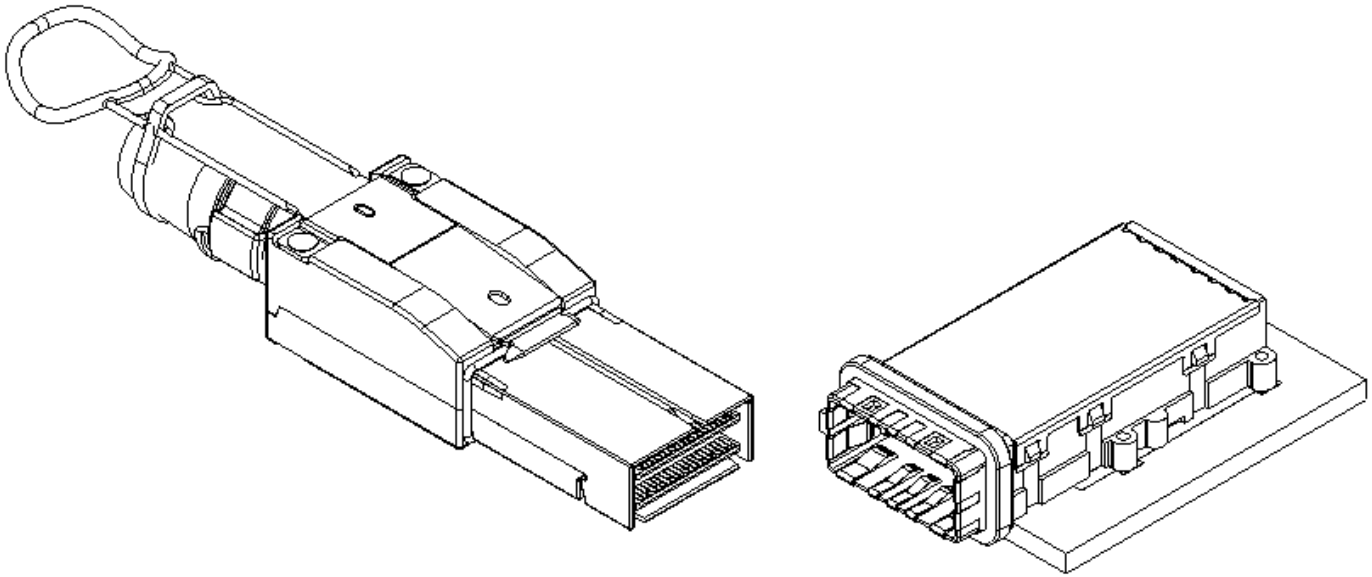

**FIGURE 3-1 GENERAL VIEW OF A SHIELDED INTEGRATED CONNECTOR**

4 Datums

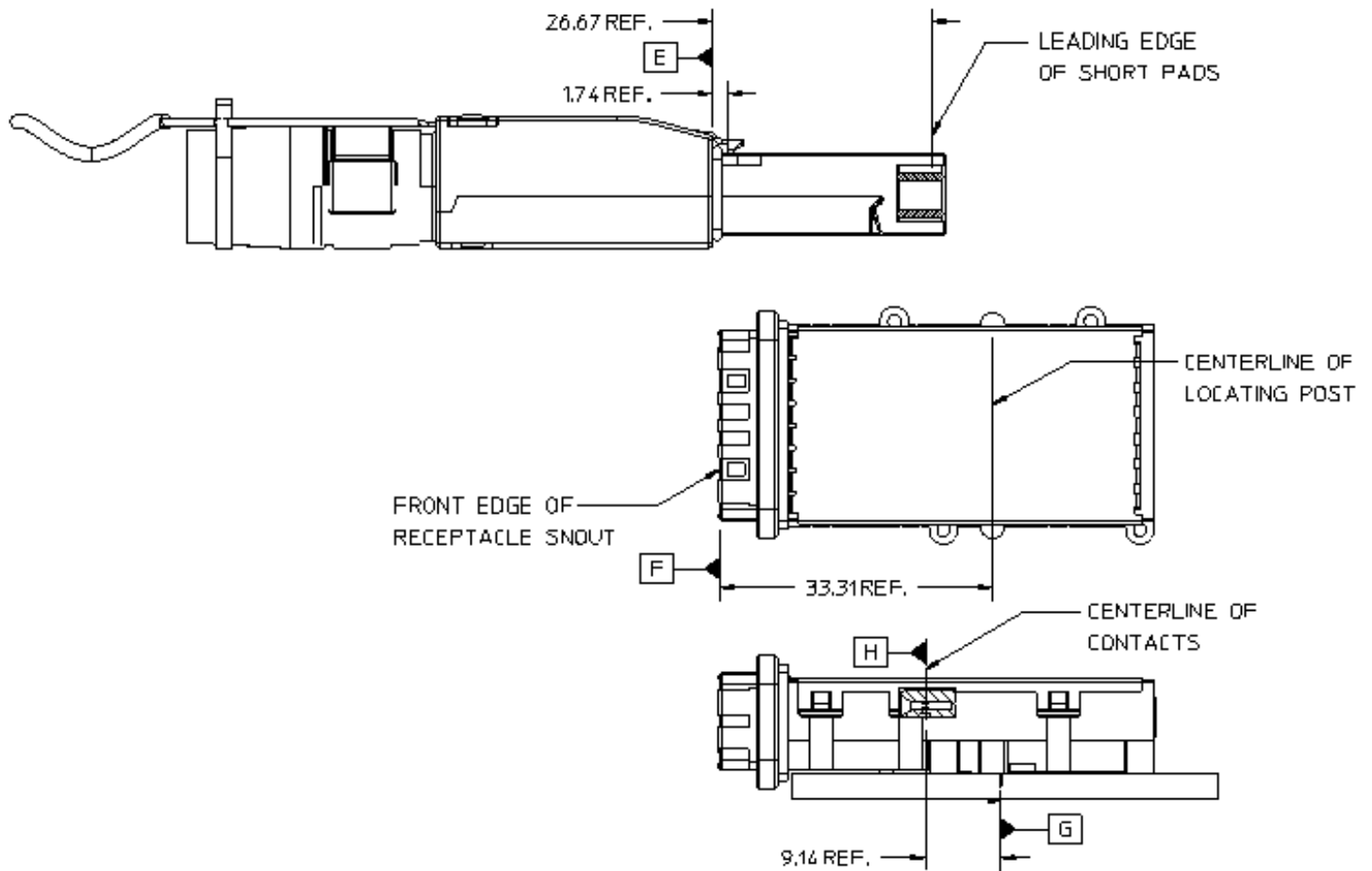

FIGURE 4-1 DEFINITION OF DATUMS

TABLE 4-1 DEFINITION OF DATUMS

Datum	Description
A	Width of Paddle Card
B	Top Surface of Paddle Card
C	Leading Edge of Short Signal Pad on Paddle Card
D	Width of Plug Snout
E	Body of Plug
F	Front Edge of Receptacle Snout (does not include EMI Fingers)
G	Centerline of First Row of Connector Compliant Tails
H	Centerline of Receptacle Contacts
J	Centerline of Outer Holes
K	Centerline of First Row of PCB Holes
L	Surface of PCB
M	Width of Receptacle Snout
N	Bottom of Die Cast Housing
P	Bottom of Plug Snout
X, Y	Reference 0, 0 on Host Board (application specific)

5 Shielded Connector Dimensional Requirements

5.1 Plug Paddle Card

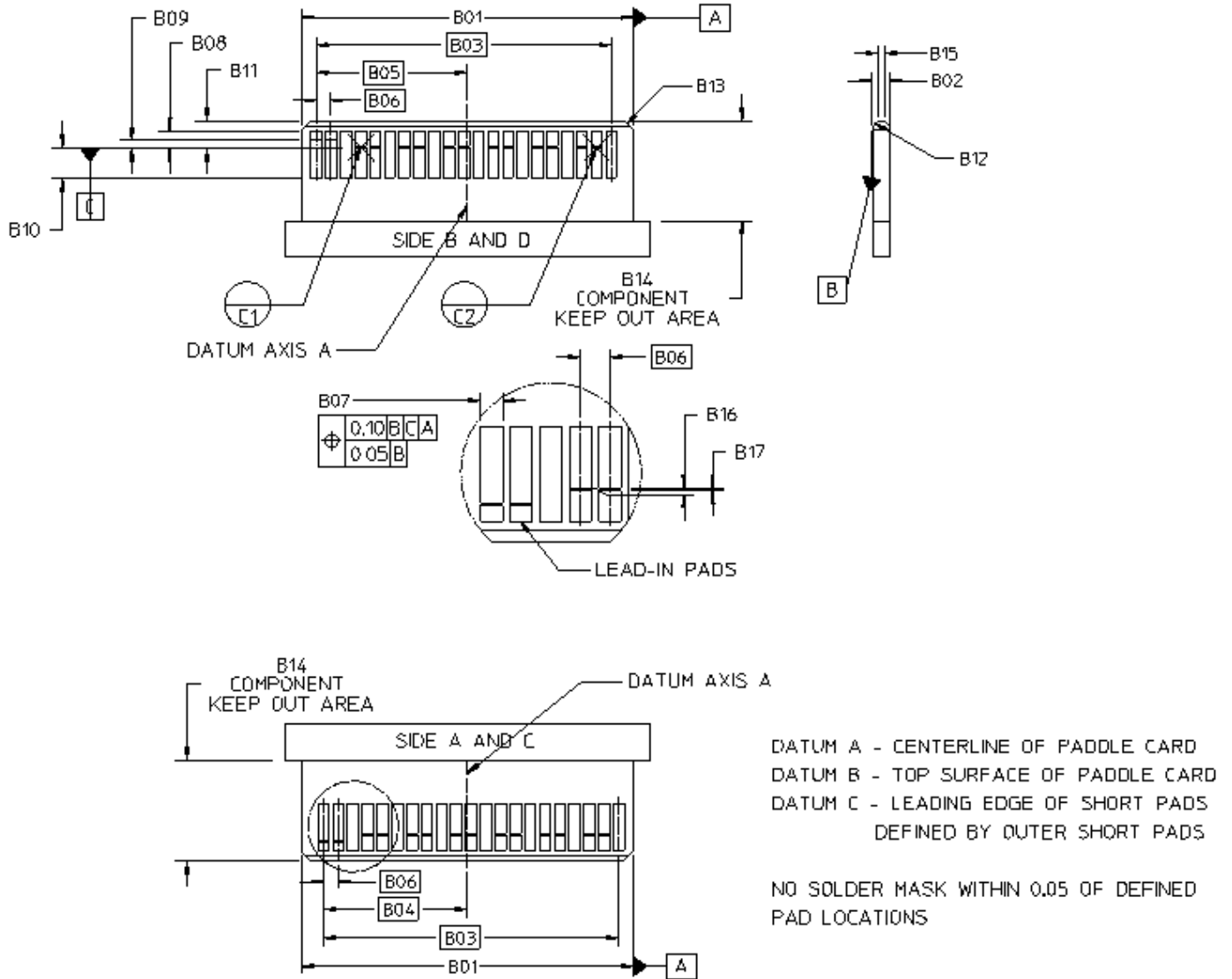
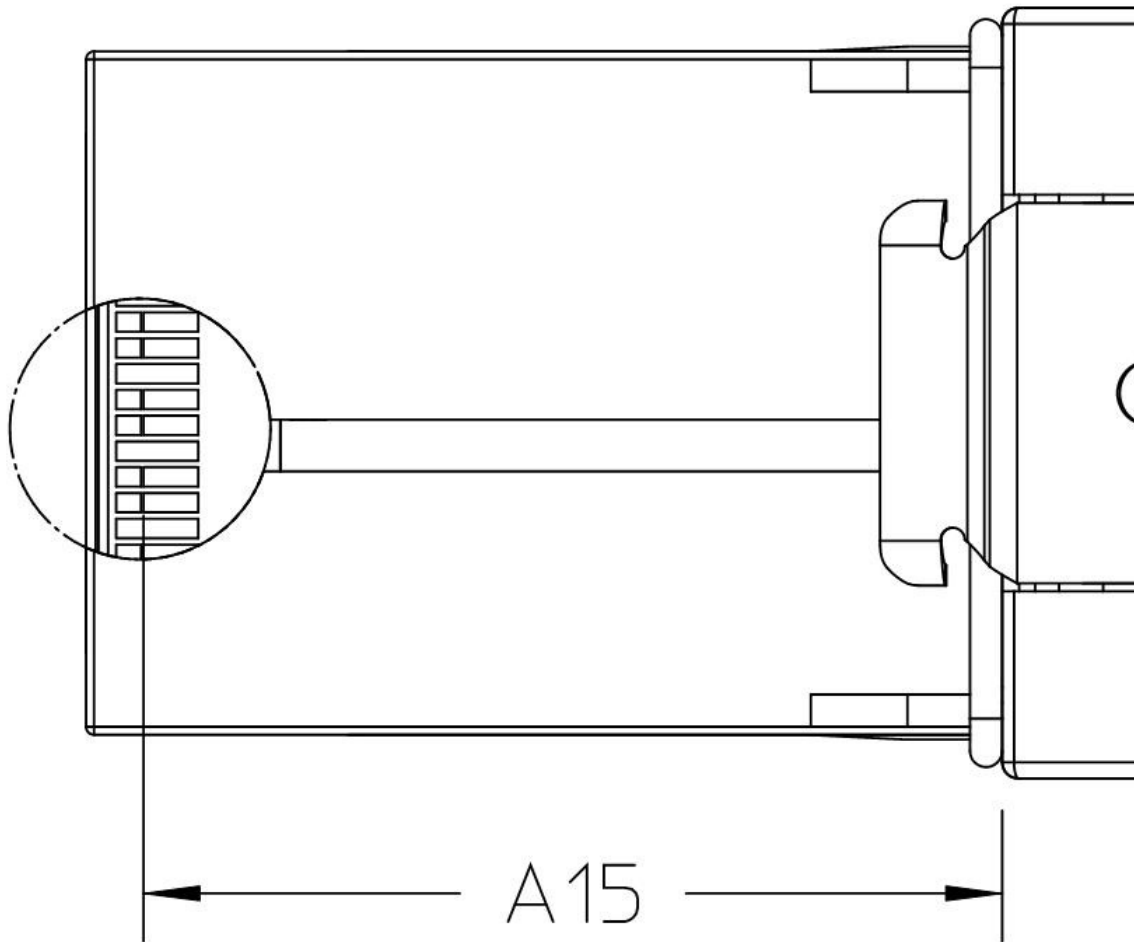

FIGURE 5-1 PLUG PADDLE CARD

TABLE 5-1 PLUG PADDLE CARD DIMENSIONS

Designator	Description	Dimension	Tolerance
B01	Paddle Card Width	18.00	0.10
B02	Paddle Card Thickness	1.00	0.10
B03	Overall Pad Centers	16.00	Basic
B04	Card Center to Outer Pad - Sides A& C	7.80	Basic
B05	Card Center to Outer Pad - Sides B& D	8.20	Basic
B06	Pad Center to Center (Pitch)	0.80	Basic
B07	Pad Width	0.60	0.03
B08	Front Pad Length	0.90	0.05
B09	Front Pad Spacing	0.40	0.05
B10	Pad Length	1.55	Min.
B11	Card Edge to Second Pad	1.45	0.10
B12	Lead-in Chamfer x 45 degrees	0.30	0.05
B13	Lead-in Chamfer x 45 degrees	0.50	0.05
B14	Component Keep Out Area	5.40	Min.
B15	Lead-in Flat	0.36	Ref
B16	Short Pad to Datum C	0.00	0.03
B17	Pad to Lead-in Pad	0.08	0.015

5.2 Free (Plug) Cable Connector



Location of Paddle Card/Contacts and Key Taper to Plug Housing  
FIGURE 5-2 PLUG (1)

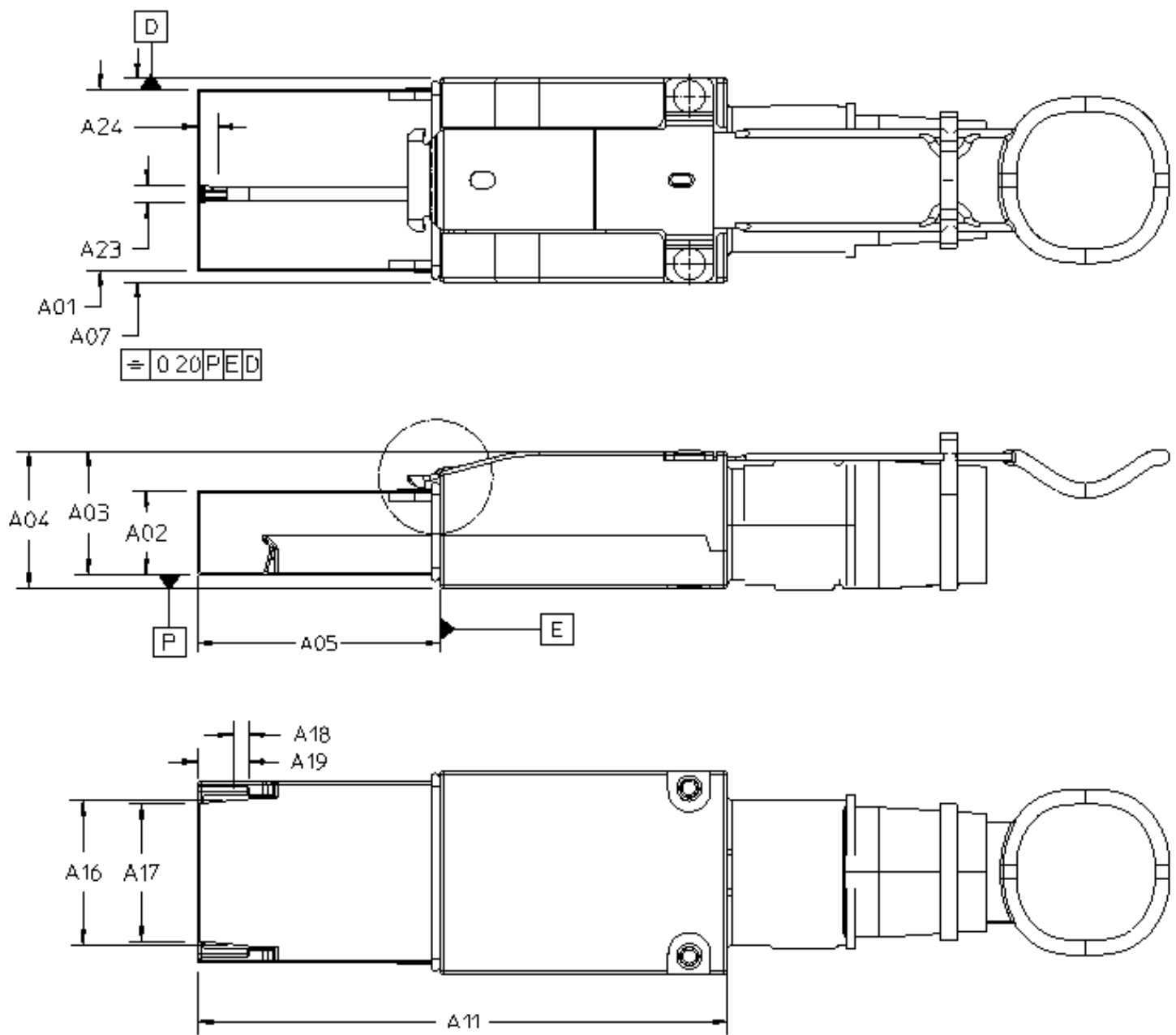

FIGURE 5-3 PLUG (2)

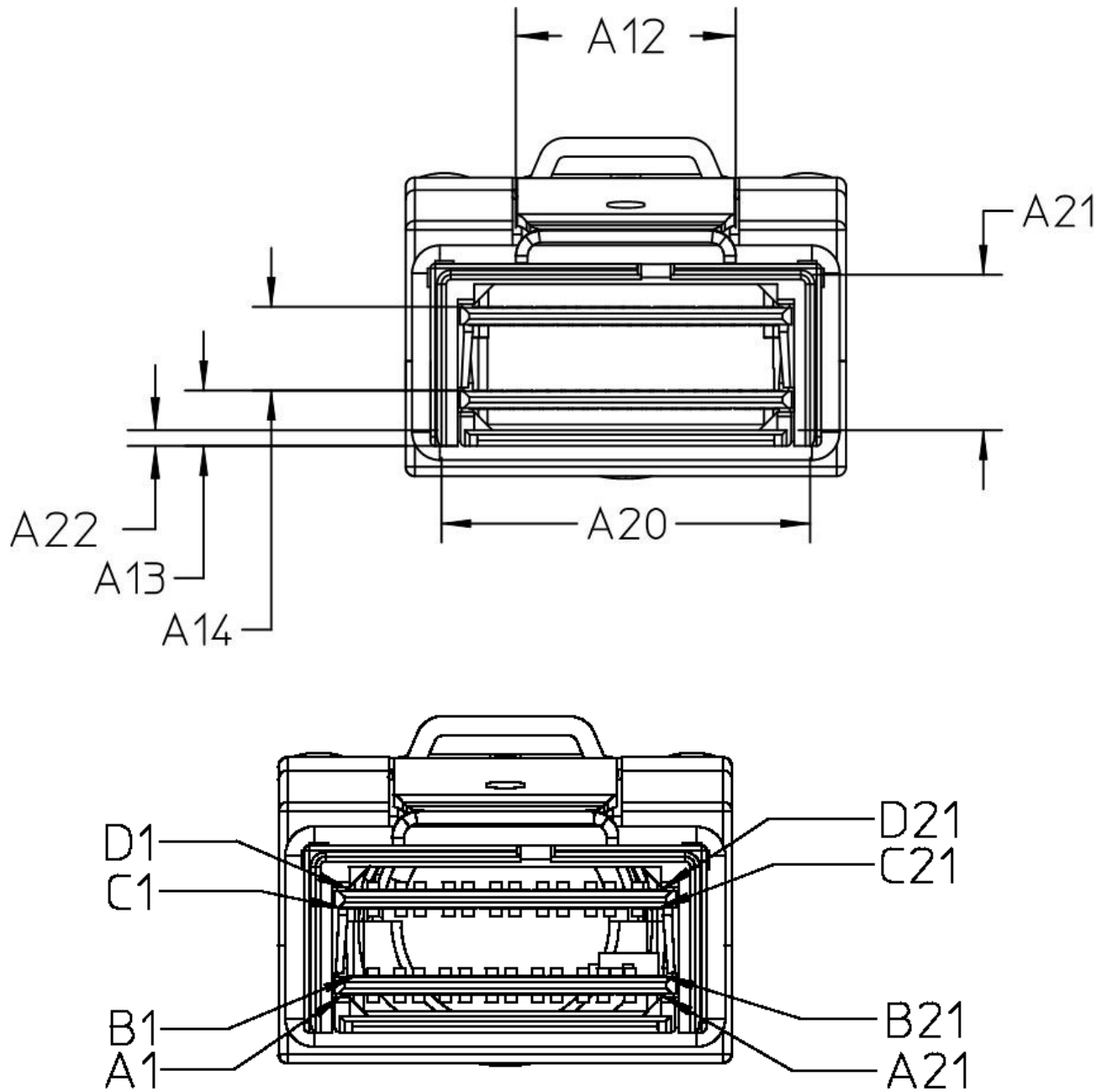
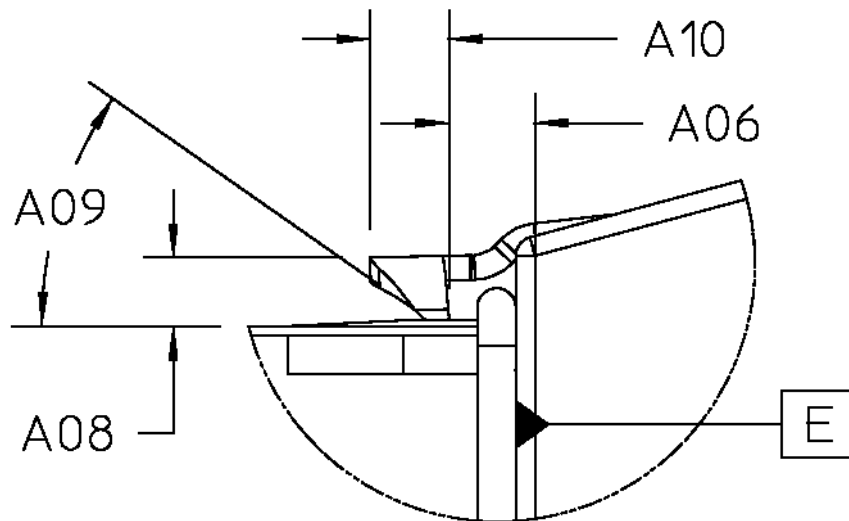

FIGURE 5-4 PLUG (3)



Latch Detail  
FIGURE 5-5 PLUG (4)

TABLE 5-2 PLUG DIMENSIONS

Designator	Description	Dimension	Tolerance
A01	Snout Width	21.20	0.13
A02	Snout Thickness	9.81	0.13
A03	Snout Bottom to Plug Top	14.60	Max
A04	Plug Body Thickness	16.21	Max
A05	Snout Length	28.45	0.13
A06	Plug Body (Datum E) to Latch	1.74	0.13
A07	Body Width	24.05	Max
A08	Barb Lead-in Height	1.14	0.10
A09	Barb Lead-in Angle	45 degrees	1 degree
A10	Barb Length	2.05	0.10
A11	Plug Overall Length	62.00	Ref.
A12	Latch Width	11.90	0.10
A13	Bottom of Snout to Top of 1st Paddle Card	2.99	0.20
A14	Top of 1st Paddle Card to Top of 2nd Paddle Card	4.50	0.10
A15	Plug Body to Short Pad (Datum C)	26.67	0.20
A16	Tongue Width - Base	16.95	0.10
A17	Tongue Width - Tip	16.10	0.20
A18	Length of Tongue - Straight Section	1.80	0.10
A19	Length of Tongue	6.00	Min.
A20	Inside Width of Snout	20.00	0.05
A21	Inside Height of Snout	8.60	0.25
A22	Tongue Thickness	0.60	Ref.
A23	Orientation Key Lead-In Width	2.00	0.25
A24	Orientation Key Lead-In Length	2.40	0.25



## 5.3 Free (Plug) Cable Connector Pull Tab

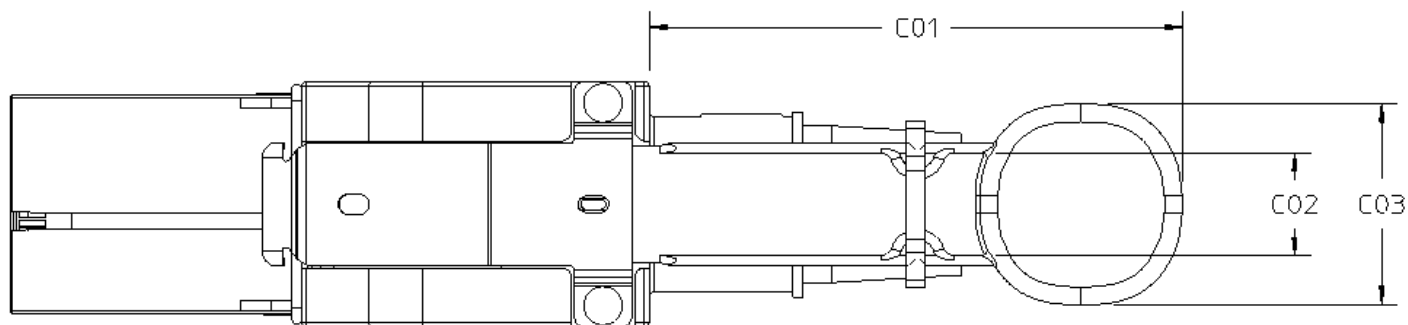

This is one possible configuration, color may be specified by the application.

**FIGURE 5-6 PLUG PULL TAB EXAMPLE**

**TABLE 5-3 PLUG PULL TAB EXAMPLE DIMENSIONS**

<b>Designator</b>	<b>Description</b>	<b>Dimension</b>	<b>Tolerance</b>
C01	Pull Tab Length	50.00	Ref
C02	Pull Tab Width	9.91	Ref
C03	Pull Tab Hole Width	19.51	Ref

5.4 Fixed (Receptacle) Right Angle Connector

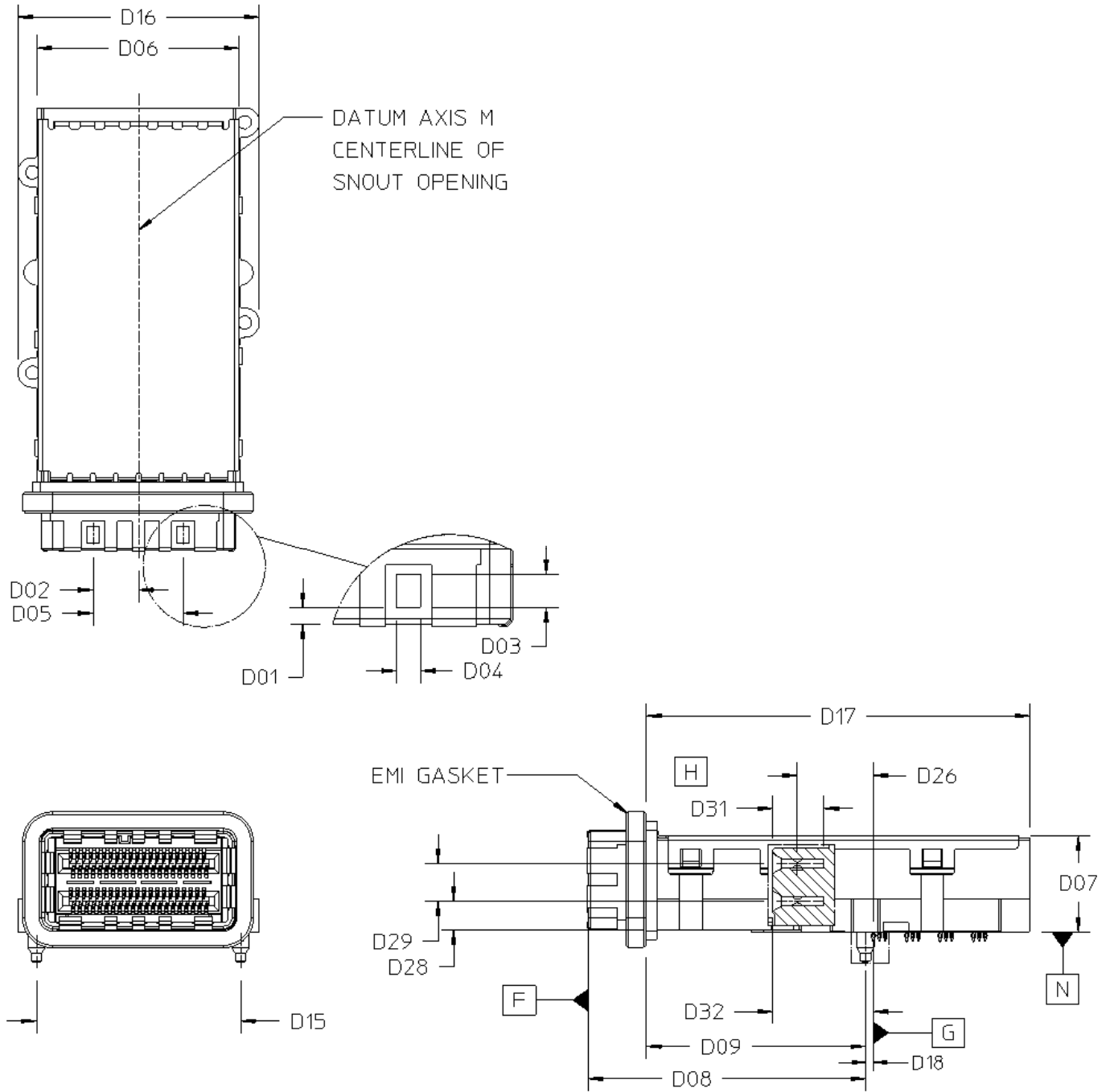

FIGURE 5-7 RECEPTACLE (1)

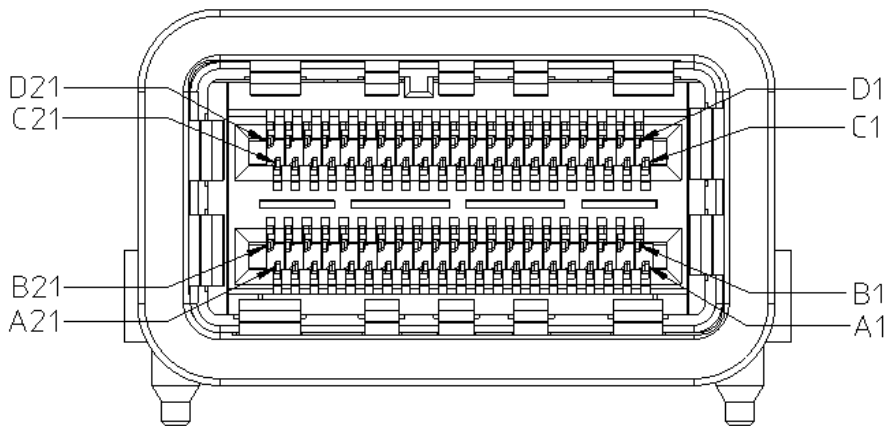
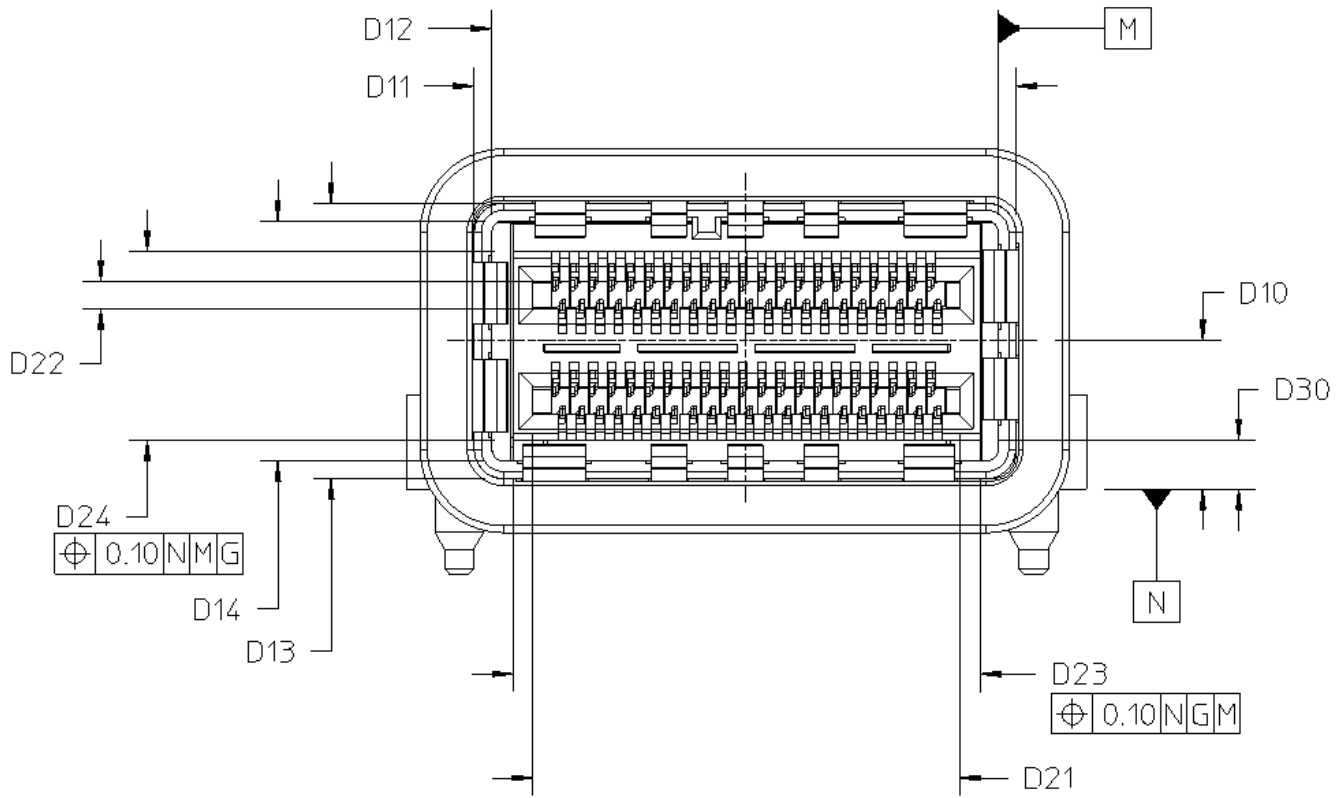

FIGURE 5-8 RECEPTACLE (2)

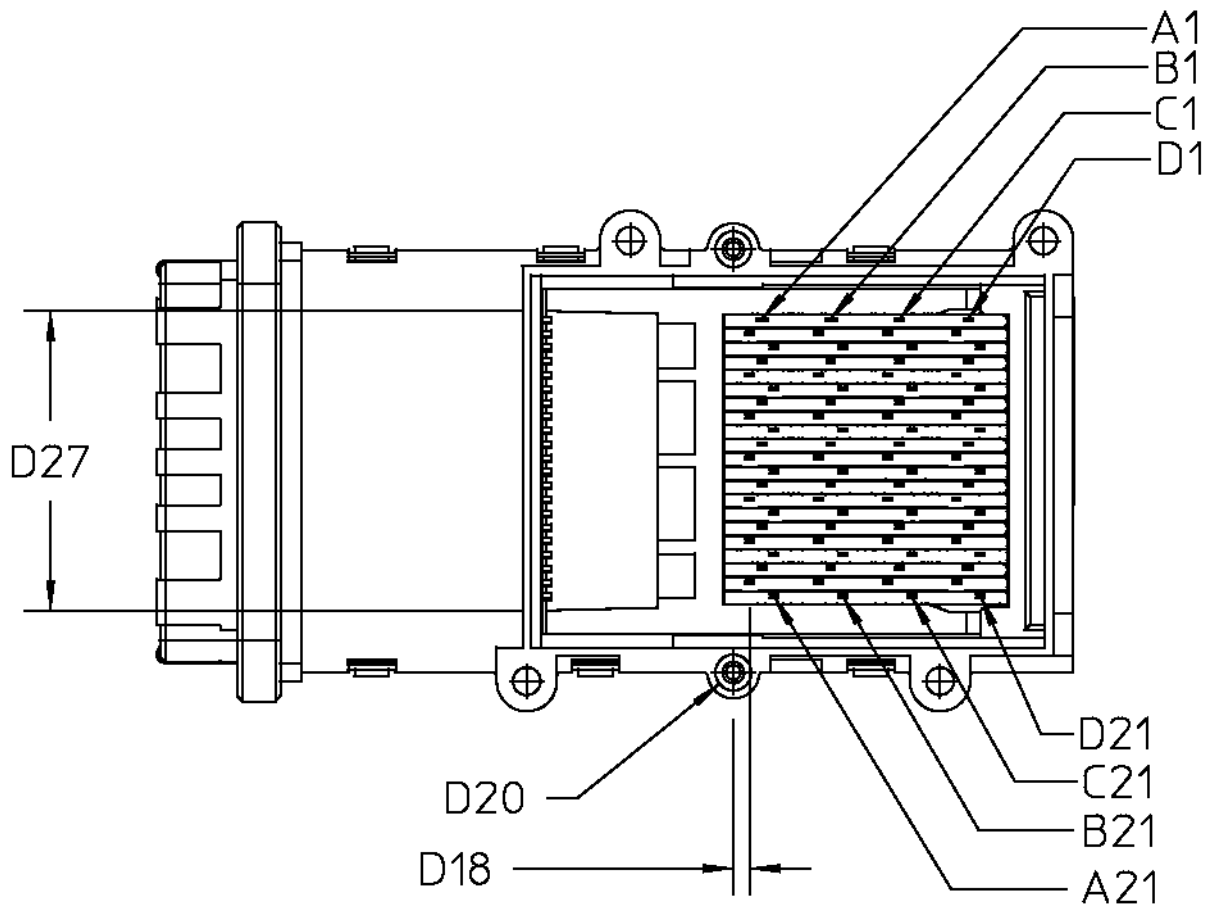

FIGURE 5-9 RECEPTACLE (3)

TABLE 5-4 RECEPTACLE DIMENSIONS

Designator	Description	Dimension	Tolerance
D01	Latch Hole from Face	0.97	0.05
D02	Latch Hole Centerline from Datum M	5.40	0.10
D03	Latch Hole Length	2.00	0.10
D04	Latch Hole Width	1.50	0.10
D05	Latch Hole to Hole	10.80	0.05
D06	Shell Width	24.23	0.25
D07	Shell Height	11.55	0.13
D08	Locating Post to Face	33.31	0.08
D09	Locating Post to EMI Shell Base	26.31	0.13
D10	Datum N to Snout Opening Centerline	6.29	0.08
D11	Snout Width	23.10	0.08
D12	Snout Opening Width	21.60	0.05
D13	Snout Height	11.70	0.08
D14	Snout Opening Height	10.20	0.05
D15	Peg Centerline to Peg Centerline	24.50	0.08
D16	Shell Width at Screw Attach Features	29.00	0.25
D17	EMI Shell Base to Back	46.04	0.25
D18	Connector Pins to Locating Post	0.95	0.05
D20	Peg Diameter	2.08	0.05
D21	Card Slot Width	18.20	0.05
D22	Card Slot Height	1.20	0.05
D23	Receptacle Body Width	19.89	0.05
D24	Receptacle Body Height	8.15	0.08
D25	---	---	0.05
D26	Contact C/L to 1st Row of Compliant Pins	9.14	0.10
D27	Housing Leg to Leg	17.35	0.05
D28	Datum N to Lower Card Slot Centerline	3.75	0.10
D29	Lower Card Slot to Upper Card Slot Centerline	4.50	0.10
D30	Datum N to Bottom of Receptacle Housing	2.10	0.10
D31	Card Slot Depth	6.13	0.08
D32	Datum G to Front of Receptacle Housing	12.07	0.10

5.5 Fixed (Receptacle) Right Angle Connector Footprint

DATUM K - DEFINED BY FIRST & LAST HOLE  
IN ROW

DATUM J - CENTERLINE OF OUTER HOLES  
IN ROW A

DATUM L - PCB SURFACE

NO SOLDER MASK WITHIN 0.05 OF DEFINED  
PAD LOCATIONS

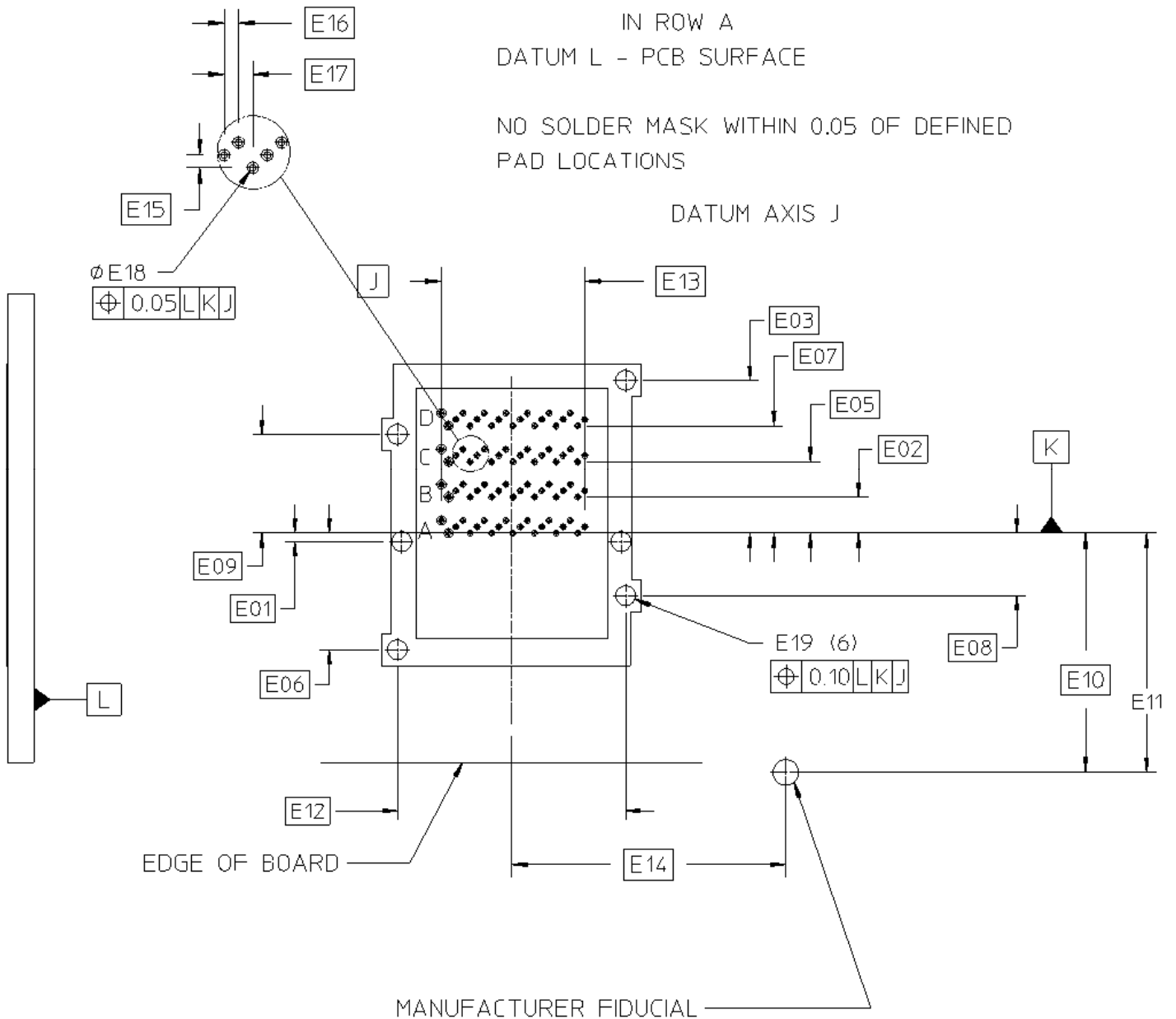

FIGURE 5-10 RECEPTACLE FOOTPRINT

TABLE 5-5 RECEPTACLE FOOTPRINT DIMENSIONS

Designator	Description	Dimension	Tolerance
E01	Shield Screw Hole to Datum K	---	Basic
E02	Row A (Datum K) to Row B	4.00	Basic
E03	Shield Screw Hole to Datum K	---	Basic
E04	Shield Post Hole to Datum K	---	Basic
E05	Row A (Datum K) to Row C	8.00	Basic
E06	Shield Post Hole to Datum K	---	Basic
E07	Row A (Datum K) to Row D	12.00	Basic
E08	Shield Screw Hole to Datum K	---	Basic
E09	Shield Screw Hole to Datum K	---	Basic
E10	Connector Datum to Manufacturer Fiducial	Basic	N/A
E11	Connector Datum to Card Edge	---	0.25
E12	Shield Mounting Hole to Mounting Hole	---	Basic
E13	Shield Pin Center to Center	16.00	Basic
E14	Connector Datum to Manufacturer Fiducial	Basic	N/A
E15	Within Row Pitch - Front to Back	---	Basic
E16	Within Row Horizontal Offset	0.80	Basic
E17	Within Row Pitch - Horizontal	1.60	Basic
E18	Contact Hole Diameter (finished PTH)	0.37	0.05
E19	Shield Mounting Hole Diameter (finished PTH)	2.20	0.05

5.6 Fixed (Receptacle) Right Angle Connector Ground Pad

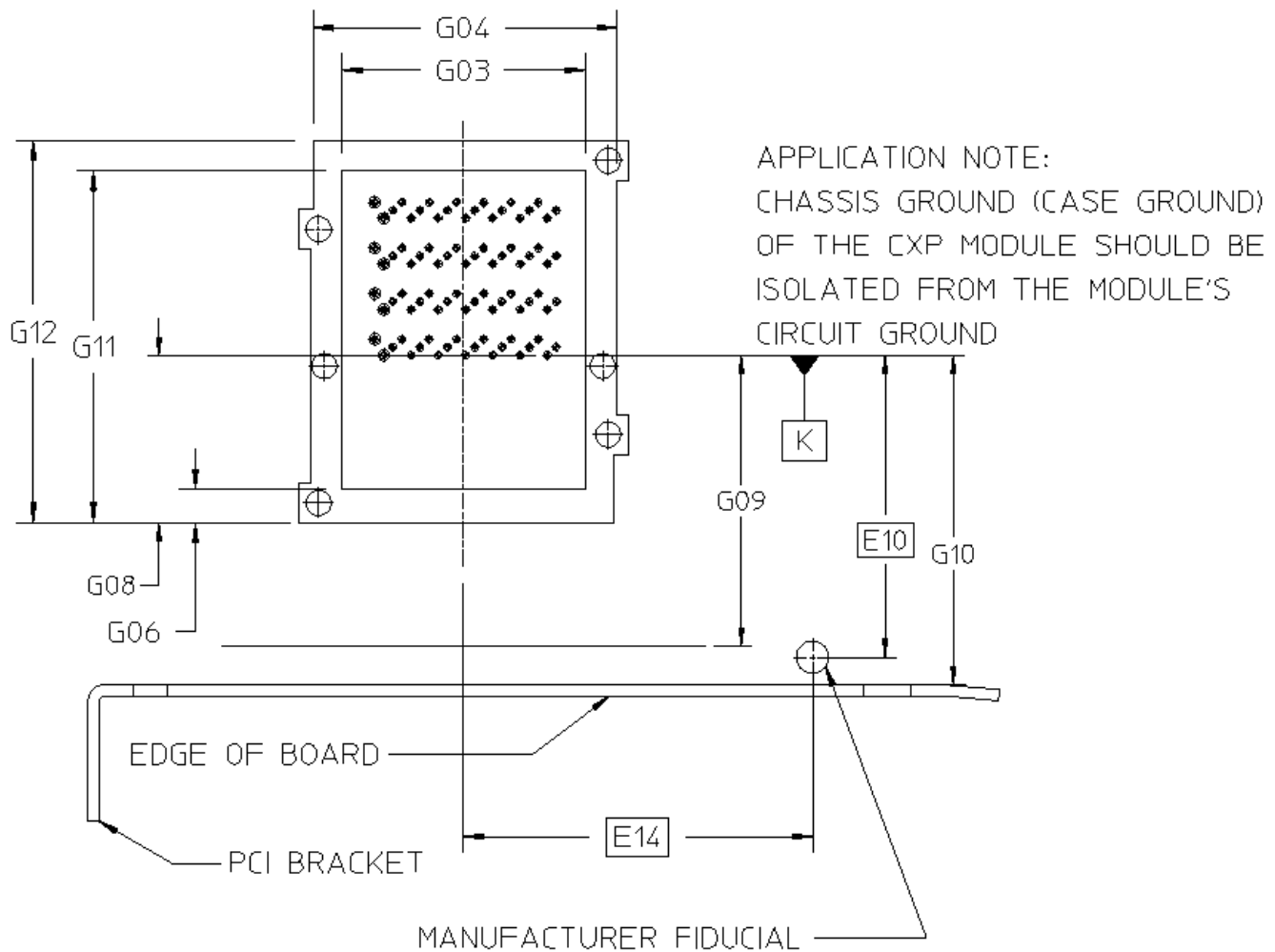

FIGURE 5-11 RECEPTACLE GROUND PAD

TABLE 5-6 RECEPTACLE GROUND PAD DIMENSIONS

Designator	Description	Dimension	Tolerance
G01	---	---	0.10
G02	---	---	0.10
G03	Ground Pad Inner Width	---	0.10
G04	Ground Pad Width	---	0.10
G05	Pad Center to Manufacturer Fiducial	Basic	N/A
G06	Ground Pad Width	---	0.10
G07	Connector Datum to Manufacturer Fiducial	Basic	N/A
G08	Connector Datum to Front Pad Edge	---	0.10
G09	Connector Datum to Card Edge	---	Ref
G10	Connector Datum to Bezel	---	0.25
G11	Ground Pad Edge to Inside Pad Edge	---	0.10
G12	Ground Pad Length	---	0.10



5.7 Fixed (Receptacle) Right Angle Connector Panel Cutout

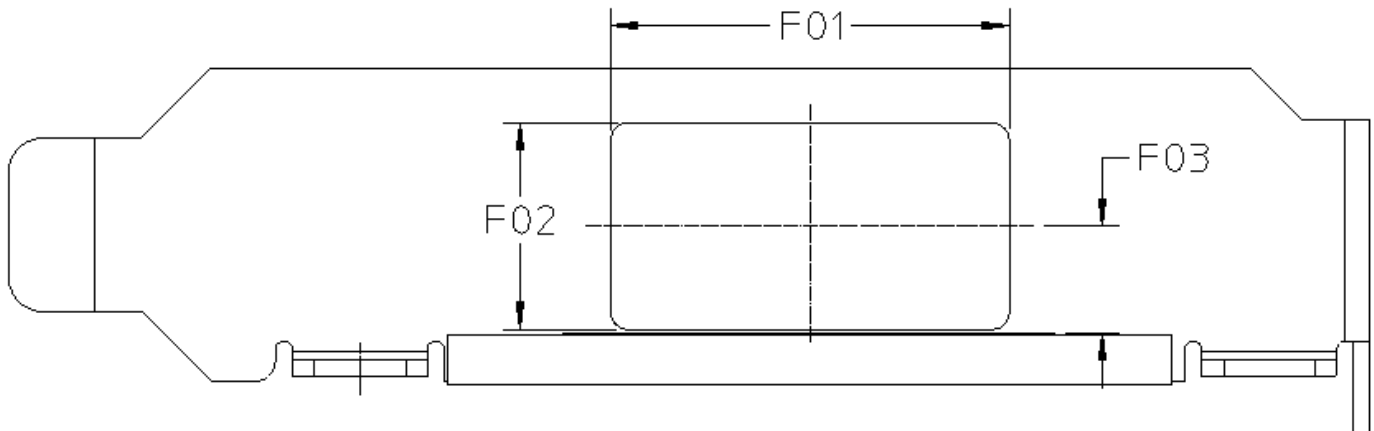

(Low profile PCIe card bracket shown for reference)

FIGURE 5-12 RECEPTACLE PANEL CUTOUT

TABLE 5-7 RECEPTACLE PANEL CUTOUT DIMENSIONS

Designator	Description	Dimension	Tolerance
F01	Cutout Length	23.50	0.05
F02	Cutout Height	12.10	0.05
F03	Cutout Location from PCB Surface	6.29	0.05

5.8 Minimum Spacing For Receptacles

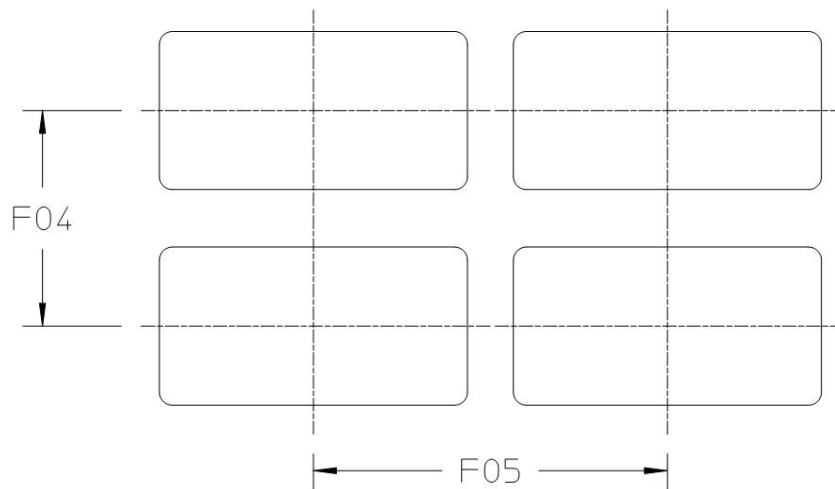

FIGURE 5-13 MINIMUM PORT SPACING - HORIZONTAL AND VERTICAL PITCH

TABLE 5-8 MINIMUM PORT SPACING DIMENSIONS

Designator	Description	Dimension	Tolerance
F04	Vertical Pitch	16.50	Min
F05	Horizontal Pitch (individual receptacles)	27.00	Min

### 5.9 Orientation Key

An orientation key is required to assure that the plug is inserted into the receptacle right side up.

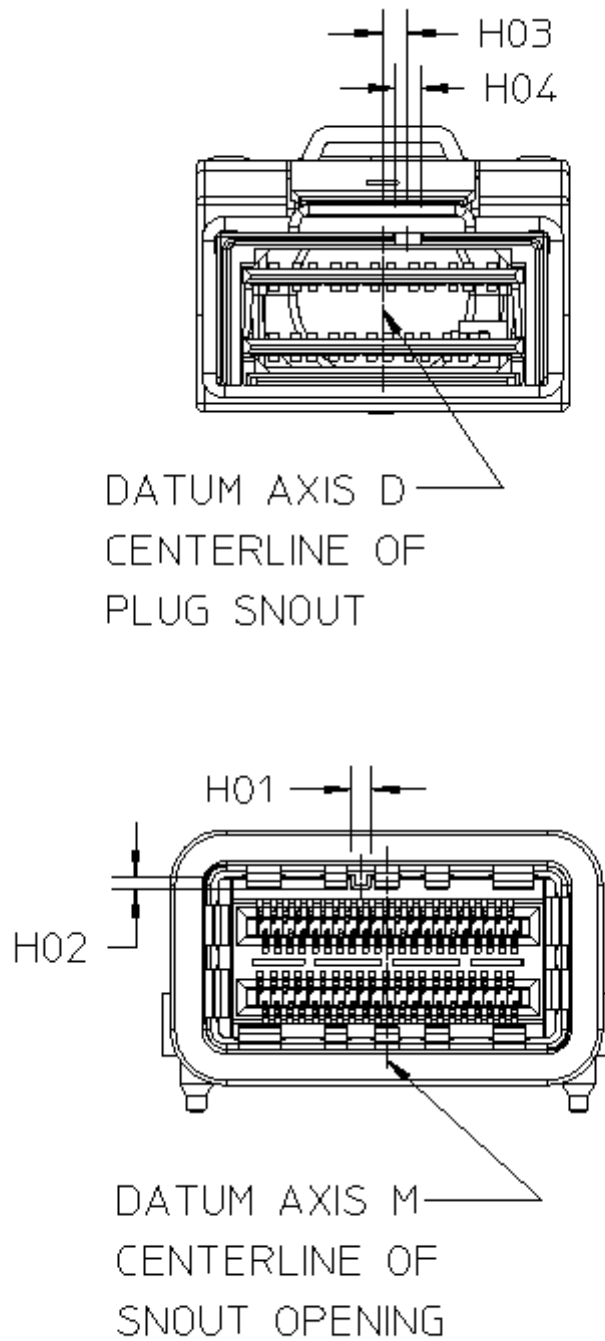

FIGURE 5-14 ORIENTATION KEY

TABLE 5-9 ORIENTATION KEY/KEYWAY DIMENSIONS

Designator	Description	Dimension	Tolerance
H01	Orientation Key Width	1.25	0.13
H02	Orientation Key Height	0.75	0.13
H03	Orientation Key Location	1.625	0.13
H04	Orientation Key Slot	1.60	0.13

### 5.10 Thermal Solution

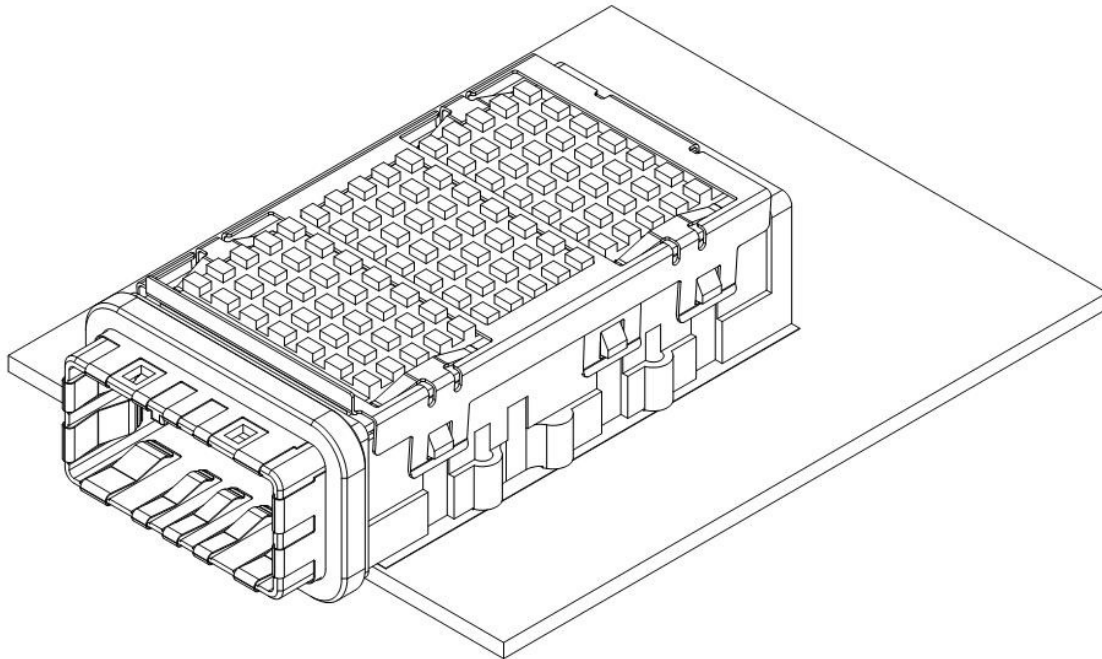

FIGURE 5-15 RECEPTACLE WITH OPTIONAL SPRING-LOADED HEAT SINK AND CLIP

5.11 Thermal Interface Definition for Plug on Plug

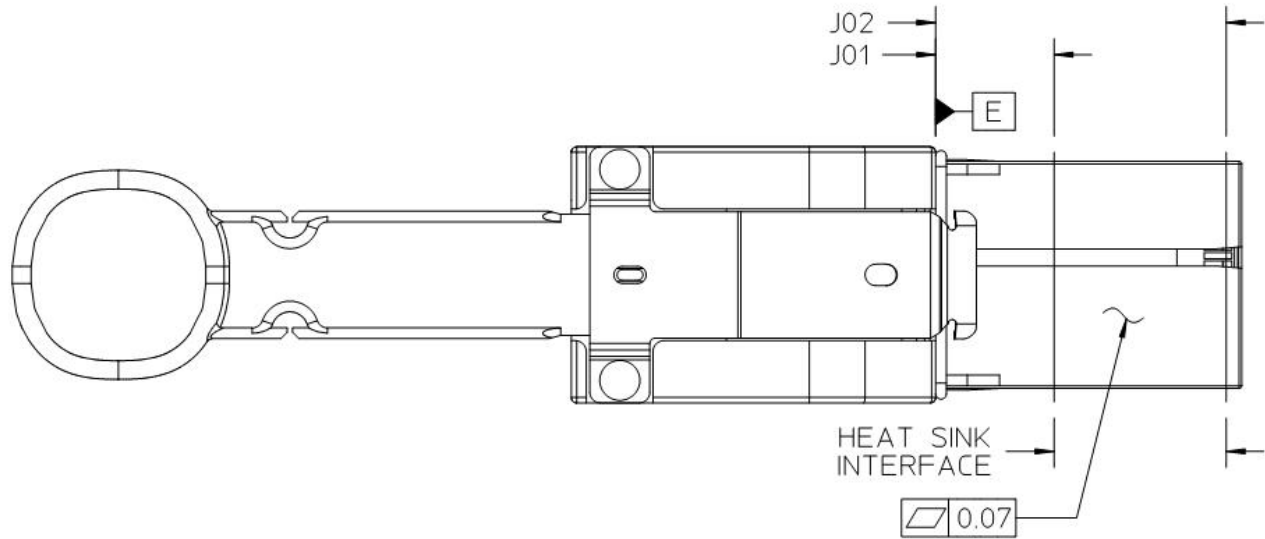

FIGURE 5-16 THERMAL INTERFACE DEFINITION FOR PLUG

TABLE 5-10 THERMAL INTERFACE DEFINITION FOR PLUG

Designator	Description	Dimension	Tolerance
J01	Plug Body to Heat Sink Interface Start	11.00	Max
J02	Plug Body to Heat Sink Interface End	27.00	Min

## 5.12 Heat Sink Configuration

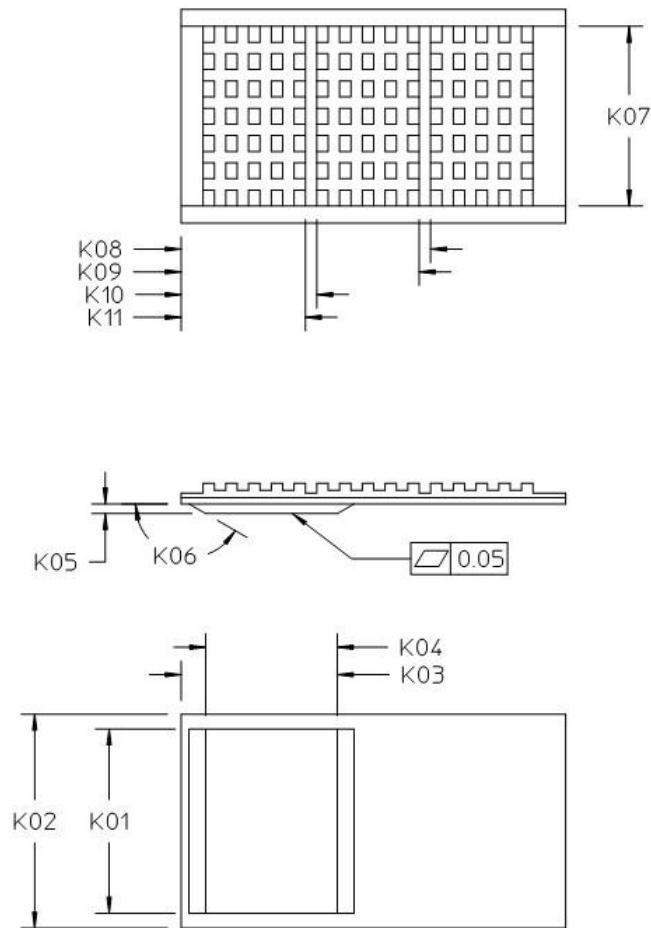

FIGURE 5-17 HEAT SINK THERMAL INTERFACE PROFILE FOR RECEPTACLE

TABLE 5-11 HEAT SINK THERMAL INTERFACE DIMENSIONS

Designator	Description	Dimension	Tolerance
K01	Heat Sink Pad Width	20.25	0.10
K02	Heat Sink Width	23.50	0.10
K03	Heat Sink Pad Back Edge	17.93	0.10
K04	Heat Sink Pad Length	14.46	0.10
K05	Heat Sink Pad Height	1.05	0.10
K06	Heat Sink Lead-In Angle	150.00	5.00
K07	Heat Sink Tower Width	19.75	0.10
K08	Heat Sink Clip Interface Zone	27.40	0.10
K09	Heat Sink Clip Interface Zone	26.15	0.10
K10	Heat Sink Clip Interface Zone	14.90	0.10
K11	Heat Sink Clip Interface Zone	13.65	0.10

## 5.13 Heat Sink Clip

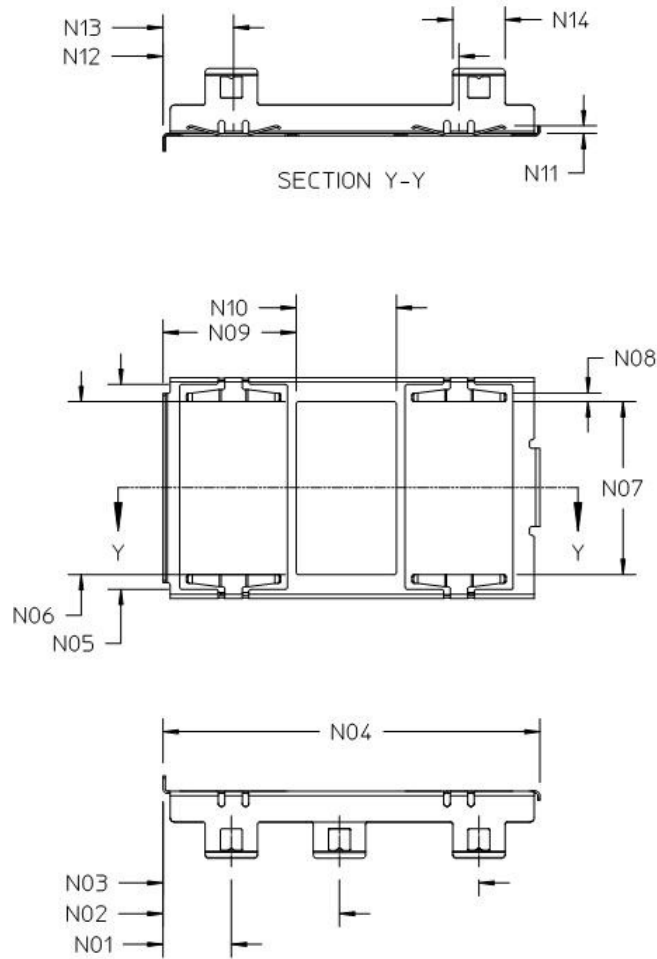

FIGURE 5-18 HEAT SINK CLIP

TABLE 5-12 HEAT SINK CLIP DIMENSIONS

Designator	Description	Dimension	Tolerance
N01	Heat Sink Clip Flange to Attach Point	7.84	0.10
N02	Heat Sink Clip Flange to Attach Point	20.25	0.10
N03	Heat Sink Clip Flange to Attach Point	36.25	0.10
N04	Heat Sink Clip Length	43.25	0.10
N05	Heat Sink Clip Cut Out Width	23.60	0.10
N06	Heat Sink Clip Cut Out Width	19.90	0.10
N07	Heat Sink Clip Finger to Finger	19.90	0.10
N08	Heat Sink Clip Finger Width	1.00	Ref
N09	Heat Sink Clip Cut Out Length	15.28	0.10
N10	Heat Sink Clip Cut Out Length	11.50	0.10
N11	Heat Sink Clip Finger Height	0.91	Ref
N12	Heat Sink Clip Finger Location	33.97	Ref
N13	Heat Sink Clip Finger Location	8.09	Ref
N14	Heat Sink Clip Attach Point Width	6.25	Max

## 5.14 Heat Sink Attach Points on Receptacle

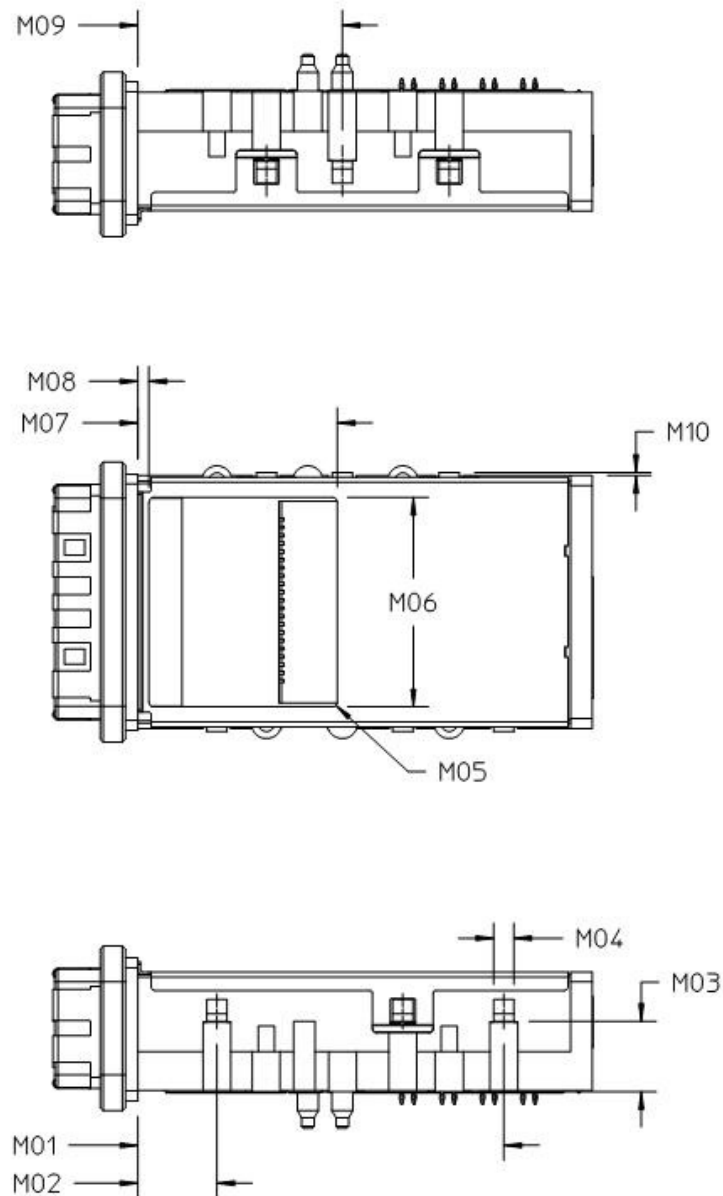

FIGURE 5-19 HEAT SINK ATTACH POINTS

TABLE 5-13 HEAT SINK ATTACH POINTS DIMENSIONS

Designator	Description	Dimension	Tolerance
M01	Flange to Heat Sink Attach Point	36.25	0.10
M02	Flange to Heat Sink Attach Point	7.84	0.10
M03	Heat Sink Attach Point Height	6.96	0.10
M04	Heat Sink Attach Point Width	2.00	0.10
M05	Heat Sink Cover Opening Radius	0.50	0.10
M06	Heat Sink Cover Opening Width	20.75	0.10
M07	Flange to Heat Sink Cover Opening	18.65	0.10
M08	Heat Sink Cover Opening Length	1.10	0.10
M09	Flange to Heat Sink Attach Point	20.25	0.10
M10	Height of Heat Sink Attach Feature	0.30	Min

## 5.15 Dust Cover for Receptacle Ports

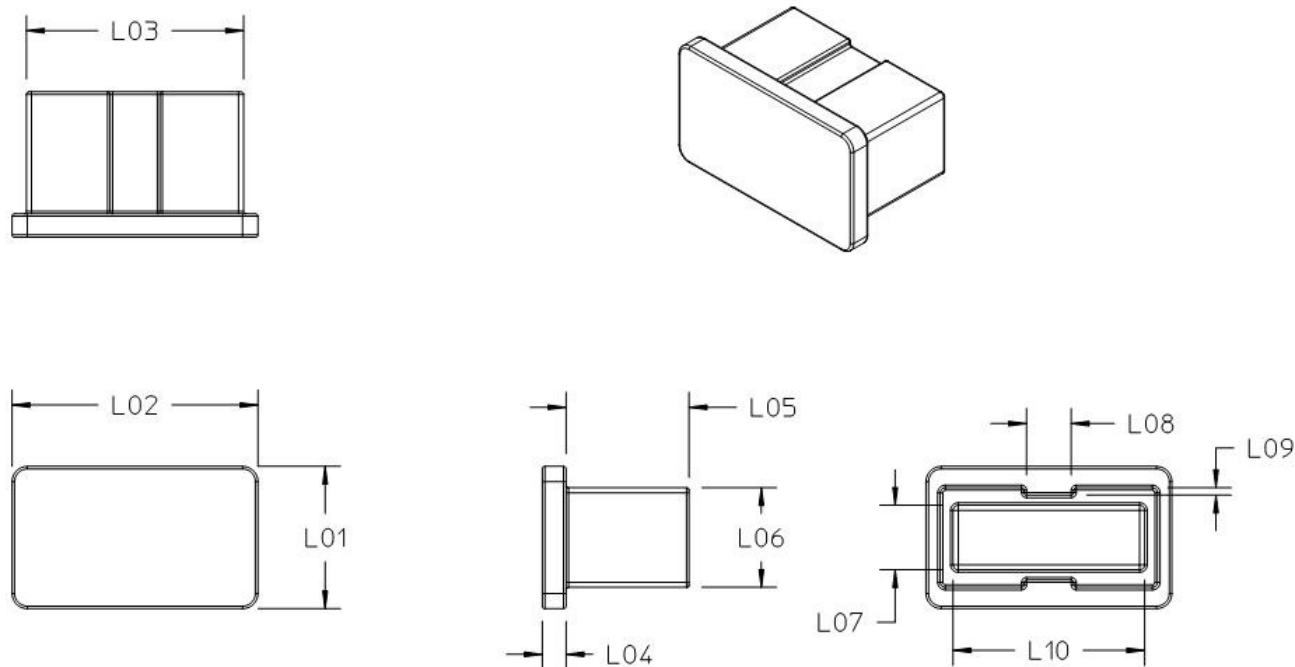

FIGURE 5-20 DUST COVER FOR RECEPTACLE PORTS

TABLE 5-14 DUST COVER FOR RECEPTACLE PORTS DIMENSIONS

Designator	Description	Dimension	Tolerance
L01	Front Height	14.00	Max
L02	Front Width	24.00	Max
L03	Body Width	21.20	0.10
L04	Front Thickness	2.00	Min
L05	Body Length	12.00	Max
L06	Body Height	9.81	0.10
L07	Body Inner Height	6.35	0.10
L08	Groove Width	4.35	0.10
L09	Groove Depth	0.73	Ref
L10	Body Inner Width	18.70	0.10



## 6 Performance Requirements

This specification conforms to the test sequences as defined in EIA-364 TS-1000.

**TABLE 6-1 TS-1000 REQUIREMENTS**

Description	Requirement
Rated Durability Cycles	250
Field Life (3, 5, 7, or 10 years)	10 year
Field Temperature (57, 60, 65, 75, or 85C)	65C degrees
Test Group 4 Option	1B
Plating Type (Precious / non-Precious)	Precious
Surface Treatment (Lubricated or non-Lubricated)	Manufacturer to specify

**TABLE 6-2 ELECTRICAL REQUIREMENTS**

Description	Requirement	Procedure
Current	0.5 A per contact	
Voltage	30 VDC per contact	
Low Level Contact Resistance	Baseline	EIA 364-23 20 mVDC, 10 mA
Insulation Resistance	1000 Megaohms minimum between adjacent contacts	100 VDC
Dielectric Withstanding Voltage	No defect or breakdown between adjacent contacts	300 VDC minimum for 1 minute

**TABLE 6-3 MECHANICAL REQUIREMENTS**

Description	Requirement	Procedure
Mating Force	150N maximum	EIA 364-13
Un-mating Force	50N maximum	EIA 364-13
Vibration	- No Damage - No discontinuity longer than 1 microsecond allowed. - 20 milliohms maximum change from initial (baseline) contact resistance	EIA 364-28
Mechanical Shock	- No Damage - 20 milliohms maximum change from initial (baseline) contact resistance	EIA 364-27

**TABLE 6-4 ENVIRONMENTAL REQUIREMENTS**

Description	Requirement	
Storage Temperature	-20C to +85C degrees	
Humidity	80 percent Relative Humidity	