

SFF specifications are available at <http://www.snia.org/sff/specifications>



SFF-8672

Specification for

QSFP+ 4X 28 Gb/s Connector (Style B)

Rev 1.2

June 8, 2018

Secretariat: SFF TA TWG

Abstract: This specification defines the mechanical specifications and general performance requirements of the 28 Gbs 0.8mm connector that is designed for use in high speed serial interconnect applications. One such use is as the 28 Gbs QSFP+ host receptacle mated to 28 Gbs QSFP+ modules or cables.

The mechanical dimensioning for 28 Gbs style QSFP connector allows backwards compatibility between QSFP modules and QSFP cages that have been developed in accordance with SFF-8436. It is anticipated that manufacturers will be able to supply existing QSFP cages, developed in accordance with SFF-8436 that will accept 28 Gbs style QSFP connector and 28 Gbs style QSFP modules.

This specification provides a common reference for systems manufacturers, system integrators, and suppliers.

This specification is made available for public review, and written comments are solicited from readers. Comments received by the members will be considered for inclusion in future revisions of this specification.

The description of a connector in this specification does not assure that the specific component is actually available from connector suppliers. If such a connector is supplied it must comply with this specification to achieve interoperability between suppliers.

POINTS OF CONTACT:

Zlatan Ljubijankic
Amphenol Canada Corp
605 Milner Avenue
Toronto, Ontario, M1B 5X6
Ph: 416-291-4401
Email: zlatanl@amphenolcanada.com

Chairman SFF TA TWG
Email: SFF-Chair@snia.org

Intellectual Property

The user's attention is called to the possibility that implementation of this Specification may require the use of an invention covered by patent rights. By distribution of this specification, no position is taken with respect to the validity of a claim or claims or of any patent rights in connection therewith. This specification is considered SNIA Architecture and is covered by the SNIA IP Policy and as a result goes through a request for disclosure when it is published. Additional information can be found at the following locations:

- Results of IP Disclosures: <http://www.snia.org/sffdisclosures>
- SNIA IP Policy: <http://www.snia.org/ippolicy>

Change History

June 1, 2011

- Corrected figure numbering and relevant references
- In Table 4-2, changed text to "Peg to Row B 7.69 +/- 0.10"
- Changed maximum frequency for Insertion Loss requirement from 12.5 GHz to 14 GHz to be consistent with SFF-8662
- Changed maximum frequency for Return Loss and Common Mode Through Conversion requirements from 25 GHz to 14 GHz to be consistent with SFF-8662

June 2, 2011

- Corrected typos on dimensions A07, A09, A10, A11, and B13
- Changed "includes connector cable to connector interface and board termination pads" to "includes host board interface, connector and card interface"
- Renamed "Return Loss" to "Differential Return Loss" and "Common Mode Conversion" to "Differential to Common Mode Conversion"
- Added Common Mode Return Loss requirement
- Clarified electrical performance requirements in Table 5-2

June 23, 2011

- Added Figure 4-1 to define datums
- Document title changed from 25 Gb/s to 28 Gb/s
- Added dimensions for the diamond peg on the left side of Figure 4-2
- Added a "B" to the B21 dimension in Figure 4-2
- Changed maximum frequency for Common Mode Return Loss requirement to 14 GHz

July 20, 2011

- Edited document Scope (Section 1) to include information about EMI performance

October 3, 2011

- Minor editorial changes (e.g. alphabetizing Definitions section)

December 30, 2011 (Rev 0.7)

- Corrected ratings on power pins

January 8, 2012 (Rev 0.8)

- Corrected "fixed" and "free" in Figure 2-1

January 16, 2012 (Rev 0.8)

- Added Section 1.2 on titling; changed 28G references to 28 Gb/s

February 6, 2012 (Rev 0.9)

- Replaced Figure 5-1 to correct Datums H and J

January 9, 2013 (Rev 1.0)

- Letter committing to SFF Patent Policy not yet received; reverting to Development status

March 2, 2018 (Rev 1.1)

- Updated to SNIA format
- Reformatted Change History
- Fixed broken links in Foreword
- Updated Applications (Section 1.1)
- Added EIA document references
- Clarified “fixed” and “free” definitions
- All references to “pluggable modules,” “plugs” or “modules” change to “module”; added definition for module
- Minor editorial issues resolved
- Edited Table captions
- The tolerance for lead-in chamfer (dimension A16) was changed from 0.05mm to 0.10mm. The 0.05mm tolerance was found to be too tight to be easily manufactured in large volumes. This change was made based on the results of the straw poll that closed January 12, 2018.
- Updated section 6 (Connector Performance Requirements) to agree with other SFF documentation for QSFP
- NOTE: During the review period for this revision, comments to make the connector footprint informative and to remove SI performance requirements were submitted. Resolution of these comments have been deferred until a future revision of this specification.

June 8, 2018 (Rev 1.2)

- Updated tolerance of dimension A14 in Table 5-1.
- Corrected typo in Table 6-2 for Vibration test.

Foreword

The development work on this specification was done by the SNIA SFF TWG, an industry group. Since its formation as the SFF Committee in August 1990, the membership has included a mix of companies which are leaders across the industry.

When 2 1/2" diameter disk drives were introduced, there was no commonality on external dimensions e.g. physical size, mounting locations, connector type, connector location, between vendors. The SFF Committee provided a forum for system integrators and vendors to define the form factor of disk drives.

During their definition, other activities were suggested because participants in SFF faced more challenges than the form factors. In November 1992, the charter was expanded to address any issues of general interest and concern to the storage industry. The SFF Committee became a forum for resolving industry issues that are either not addressed by the standards process or need an immediate solution.

In July 2016, the SFF Committee transitioned to SNIA (Storage Networking Industry Association), as a TA (Technology Affiliate) TWG (Technical Work Group).

Industry consensus is not a requirement to publish a specification because it is recognized that in an emerging product area, there is room for more than one approach. By making the documentation on competing proposals available, an integrator can examine the alternatives available and select the product that is felt to be most suitable.

SFF meets during the T10 (see www.t10.org) and T11 (see www.t11.org) weeks, and SSWGs (Specific Subject Working Groups) are held at the convenience of the participants.

Many of the specifications developed by SFF have either been incorporated into standards or adopted as standards by ANSI, EIA, JEDEC and SAE.

For those who wish to participate in the activities of the SFF TWG, the sign-up for membership can be found at:

<http://www.snia.org/sff/join>

The complete list of SFF Specifications which have been completed or are currently being worked on by the SFF Committee is contained in the document SFF-8000 which can be found at:

<http://www.snia.org/sff/specifications>

Suggestions for improvement of this specification will be welcome, they should be submitted to:

<http://www.snia.org/feedback>

CONTENTS

1. Scope	6
1.1 Application Specific Criteria	6
1.2 Copyright	6
1.3 Disclaimer	6
2. References	7
2.1 Industry Documents	7
2.2 Sources	7
2.3 Conventions	7
2.4 Definitions	8
3. General Description	11
4. Datums	13
5. Connector Dimensions	14
5.1 Free (Module) Paddle Card	14
5.2 Fixed (Receptacle) Right Angle Connector	16
5.3 Fixed (Receptacle) Right Angle Connector Footprint	18
6. Connector Performance Requirements	19

FIGURES

Figure 2-1 Fixed and Free Definition	9
Figure 3-1 General View of Fixed (Receptacle)	12
Figure 4-1 Datum Definitions	13
Figure 5-1 Free (Module) Paddle Card	14
Figure 5-2 Fixed (Receptacle) Right Angle Connector	16
Figure 5-3 Fixed (Receptacle) Right Angle Connector Footprint	18

TABLES

Table 4-1 Datum Descriptions	13
Table 5-1 Free (Module) Paddle card Dimensions	15
Table 5-2 Fixed (Receptacle) Right Angle Connector Dimensions	17
Table 5-3 Fixed (Receptacle) Right Angle Connector Footprint Dimensions	19
Table 6-1 TS-1000 Test Parameters and Criteria	19
Table 6-2 Electrical Test Parameters and Criteria	20
Table 6-3 Mechanical Performance Requirement	21
Table 6-4 Environmental Performance Requirement	21

1. Scope

terminology and mechanical requirements for a mating interface and physical embodiment of the 28 Gbs 0.8mm QSFP Connector. This connector is completely backwards compatible when mated to a connector and Cage/Shield that is in accordance with SFF-8436. When mating a 28 Gbs connector to a 10G backwards compatible connector per SFF-8436 the EMI shielding shall pass the application 10G EMI requirements. When mating a 28 Gbs connector to a 28 Gbs connector the EMI shielding shall pass the application 28 Gbs EMI requirements. See SFF-8436 for the mechanical design of the QSFP Cage/Shield which enables a shielded interface and SFF 8661 for the physical embodiment of the mating module.

1.1 Application Specific Criteria

InfiniBand, Ethernet, Fibre Channel, SAS, and other standards define requirements on the characteristic impedance and ability to transmit multi-gigabit signals for cable assemblies and backplanes. When this connector is used in such an application, it is subject to the requirements of the appropriate standard.

1.2 Copyright

The SNIA hereby grants permission for individuals to use this document for personal use only, and for corporations and other business entities to use this document for internal use only (including internal copying, distribution, and display) provided that:

1. Any text, diagram, chart, table or definition reproduced shall be reproduced in its entirety with no alteration, and,
2. Any document, printed or electronic, in which material from this document (or any portion hereof) is reproduced shall acknowledge the SNIA copyright on that material, and shall credit the SNIA for granting permission for its reuse.

Other than as explicitly provided above, there may be no commercial use of this document, or sale of any part, or this entire document, or distribution of this document to third parties. All rights not explicitly granted are expressly reserved to SNIA.

Permission to use this document for purposes other than those enumerated (Exception) above may be requested by e-mailing copyright_request@snia.org. Please include the identity of the requesting individual and/or company and a brief description of the purpose, nature, and scope of the requested use. Permission for the Exception shall not be unreasonably withheld. It can be assumed permission is granted if the Exception request is not acknowledged within ten (10) business days of SNIA's receipt. Any denial of permission for the Exception shall include an explanation of such refusal.

1.3 Disclaimer

The information contained in this publication is subject to change without notice. The SNIA makes no warranty of any kind with regard to this specification, including, but not limited to, the implied warranties of merchantability and fitness for a particular purpose. The SNIA shall not be liable for errors contained herein or for incidental or consequential damages in connection with the furnishing, performance, or use of this specification.

Suggestions for revisions should be directed to <http://www.snia.org/feedback/>

2. References

2.1 Industry Documents

- Ethernet IEEE 802.3ba 40GbE
- Ethernet IEEE 802.3bj 100GbE
- InfiniBand IBTA QDR/FDR/EDR
- T10 SAS 2-1 (Serial Attached SCSI)
- T10 SAS-3
- T10 SAS-4
- T11 FC-PI-5 (Fibre Channel Physical Interface)
- T11 FC-PI-6
- SFF-8410 High Speed Serial Testing for Copper Links
- SFF-8661 QSFP+ 4X 28 Gb/s Module (Style A)
- SFF-8663 QSFP+ 28 Gb/s Cage (Style A)
- SFF-8665 QSFP+ 4X 28 Gb/s Pluggable Transceiver Solution (QSFP28)
- SFF-8683 QSFP+ Cage
- SFF-8672 QSFP+ 4X 28 Gb/s Connector (Style B)
- EIA-364-1000 Environmental Test Methodology for Assessing the Performance of Electrical Connectors and Sockets Used in Controlled Environment Applications
- EIA-364-09 Durability Test Procedure for Electrical Connectors and Contacts
- EIA-364-13 Mating and Unmating Forces Test Procedure for Electrical Connectors
- EIA-364-20 Withstanding Voltage Test Procedure for Electrical Connectors, Sockets and Coaxial Contacts
- EIA-364-21 Insulation Resistance Test Procedure for Electrical Connectors, Sockets, and Coaxial Connectors
- EIA-364-23 Low Level Contact Resistance Test Procedure for Electrical Connectors and Sockets
- EIA-364-27 Mechanical Shock (Specified Pulse) Test Procedure for Electrical Connectors
- EIA-364-28 Vibration Test Procedure for Electrical Connectors and Sockets
- EIA-364-70 Temperature Rise versus Current Test Procedure for Electrical Connectors and Sockets

2.2 Sources

There are several projects active within the SFF TWG. The complete list of specifications which have been completed or are still being worked on is contained in the document SFF-8000 which can be found at <http://www.snia.org/sff/specifications>.

Copies of ANSI standards may be purchased from the InterNational Committee for Information Technology Standards (<http://www.techstreet.com/incitsgate.tmpl>).

2.3 Conventions

The dimensioning conventions are described in ANSI-Y14.5M, Geometric Dimensioning and Tolerancing. All dimensions are in millimeters, which are the controlling dimensional units (if inches are supplied, they are for guidance only).

The ISO convention of numbering is used i.e., the thousands and higher multiples are separated by a space and a period is used as the decimal point. This is equivalent to the English/American convention of a comma and a period.

American	French	ISO
0.6	0,6	0.6
1,000	1 000	1 000
1,323,462.9	1 323 462,9	1 323 462.9

2.4 Definitions

For the purpose of SFF Specifications, the following definitions apply:

Advanced grounding contacts: Connector contacts that mate first and break last and are capable of carrying power ground return currents and performing electrostatic discharge. Other terms sometimes used to describe these features are: grounding pins, ESD contacts, grounding contacts, static drain, and pre-grounding contacts.

Alignment guides: Connector features that preposition insulators prior to electrical contact. Other terms sometimes used to describe these features are: guide pins, guide posts, blind mating features, mating features, alignment features, and mating guides

Board Termination Technologies: Surface mount single row, surface mount dual row, through hole, hybrid, straddle mount, pressfit.

Cable Termination: The attachment of wires to the termination side of a connector. Schemes commonly used in the industry are IDC (Insulation Displacement Contact), IDT (Insulation Displacement Termination), wire slots, solder, weld, crimp, braise, etc.

Contact mating sequence: Order of electrical contact during mating/unmating process. Other terms sometimes used to describe this feature are: contact sequencing, contact positioning, make first/break last, EMLB (early make late break) staggered contacts, and long pin / short pin.

Fixed: Adopted from EIA standard terminology as the gender that most commonly exists on the fixed end of a connection, for example, on the board or bulkhead side. In this specification "fixed" is specifically used to describe the mating side gender illustrated in Figure 2-1. It is typically used to describe the gender of the mating side of the connector that accepts its mate upon mating. Other common terms are "receptacle," "female," and "socket connector."

Fixed Board: A connector that uses a fixed gender mating side and a termination side suitable for any of the printed circuit board termination technologies.

Free: Adopted from EIA standard terminology as the gender that most commonly exists on the free end of a connection, for example, on the cable side. In this specification "free" is specifically used to describe the mating side gender illustrated in Figure 2-1. It is typically used to describe the gender of the mating side of the connector that penetrates its mate upon mating. Other common terms are "plug" or "module," "male," and "pin connector."

Free Board: A connector that uses a free gender mating side and a termination side suitable for any of the printed circuit board termination technologies

Frontshell: That metallic part of a connector body that directly contacts the backshell or other shielding material that provides mechanical and shielding continuity between the connector and the cable media. Other terms sometimes used to describe this part of a cable assembly are: housing, nosepiece, cowling, and metal shroud.

Gull Wing: An SMT lead that is shaped like the outstretched wing of a seagull.

Height: Distance from board surface to farthest overall connector feature

Mating side: The side of the connector that joins and separates from the mating side of a connector of opposite gender. Other terms commonly used in the industry are mating interface, separable interface and mating face.

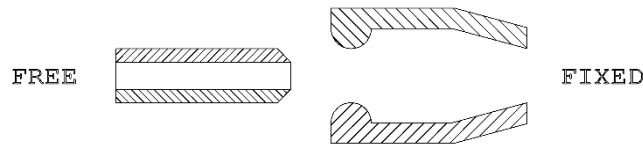

FIGURE 2-1 FIXED AND FREE DEFINITION

Module: In this specification, refers to direct attach copper (DAC), direct attach optics, and pluggable optics.

Optional: This term describes features which are not required by the SFF Specification. However, if any feature defined by the SFF Specification is implemented, it shall be done in the same way as defined by the Specification. Describing a feature as optional in the text is done to assist the reader. If there is a conflict between text and tables on a feature described as optional, the table shall be accepted as being correct.

QSFP: Quad Small FormFactor Pluggable.

Reference Dimension: A dimension used for information purposes only. A reference dimension is a repeat of a dimension or is derived from other values shown on the drawing or on related drawings. It is considered auxiliary information and does not govern production or inspection operations.

Reserved: Where this term is used for defining the signal on a connector contact its actual function is set aside for future standardization. It is not available for vendor specific use. Where this term is used for bits, bytes, fields and code values; the bits, bytes, fields and code values are set aside for future standardization. The default value shall be zero. The originator is required to define a Reserved field or bit as zero, but the receiver should not check Reserved fields or bits for zero.

Right Angle: A connector design for use with printed circuit board assembly technology where the mating direction is parallel to the plane of the printed circuit board

Single row: A connector design for use with surface mount printed circuit board assembly technology where the termination side points are arranged in one line

Single sided termination: A cable termination assembly style and a connector design style where only one side of the connector is accessible when attaching wires. This style frequently has IDC termination points that point in the same direction.

SMT: Surface Mount Technology

Straddle mount: A connector design style and a printed circuit board design style that uses surface mount termination points on both sides of the board. The connector is frequently centered between the top and bottom surfaces of the board.

Straight: A connector design for use with printed circuit board assembly technology where the mating direction is perpendicular to the plane of the printed circuit board

Surface mount: A connector design and a printed circuit board design style where the connector termination points do not penetrate the printed circuit board and are subsequently soldered to the printed circuit board

Termination side: The side of the connector opposite the mating side that is used for permanently attaching conductors to the connector. Due to contact numbering differences between mating side genders the termination side shall always be specified in conjunction with a mating side of a specific gender. Other terms commonly used in the industry are: back end, non-mating side, footprint, pc board side, and post side

Through hole: A connector design and a printed circuit board design style where the connector termination points penetrates the printed circuit board and are subsequently soldered to the printed circuit board.

3. General Description

The 28 Gbs 0.8mm connection system is based on industry-proved card edge style contacts, which mate with a single wipe, and are physically robust.

The mating interface of paddle card to receptacle body and receptacle body to circuit board are enabled with SFF-8436 Cage.

The cage/shield is mounted separately to the host board so that the stress imposed by insertion and removal of the module does not affect the signal/body solder joints.

This connector system was designed to satisfy the needs for gigabit serial data transmission applications where signals have rise times typically in the range of 20ps over a nominal 100 ohm differential balanced copper link with a common mode balance of 32.5 ohm. Design goals were Minimization of crosstalk and Minimum common mode and differential impedance discontinuity across the connector interface and speeds of up to 28 Gigabits/second on both rows of contacts.

The transmission line impedance of the connector itself (not including the termination interface to the wire or board) matches the electrical bulk cable within the tolerance allowed for the bulk cable. This connection scheme may be used in multiple places within a cabling environment. Though it has been designed for a 100 ohm environment this connector will function acceptably at other impedance levels (to be optimized on a case by case basis)

This specification includes the Minimum lengths, widths and positional tolerances of the contacts.

The connector is of a straightforward construction that does not rely on advanced materials or processes while offering superior performance, utilizing gull wing termination and grounding structure.

The 28 Gbs 0.8mm connector relies on a receiving body and paddle card, which are the primary elements to construct connectors

The primary elements provide flexible means to implement solutions for diverse applications e.g., direct board-to-board implementations can incorporate the module into the side of one board and mate directly to a receiving body on the other.

This specification defines the complete mechanical dimensions of the 28 Gbs 0.8mm connector. The 28 Gbs 0.8mm connector and cage system provide a superior alternative, in terms of data transfer rate per real estate used.

Figure 3-1 is an example, which illustrates a receiving body of the 28 Gbs 0.8mm

QSFP receptacle body.

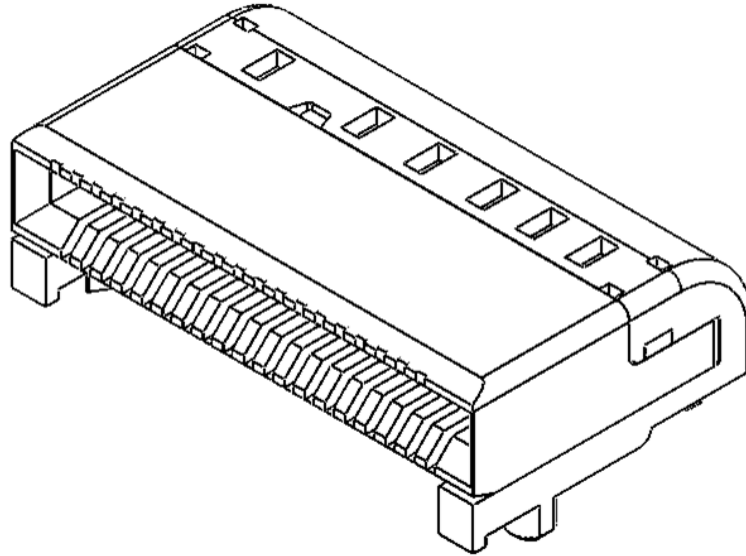

FIGURE 3-1 GENERAL VIEW OF FIXED (RECEPTACLE)

SFF-8661 defines the free module that incorporates the paddle card and the shell, which are used to form a complete assembly for use in shielded application.

SFF-8436 defines the shell/cage which provides guidance and retention for the free side, and absorbs the stress imposed by insertion and removal of the free module. This protects the signal quality of the solder joints to the body.

4. Datums

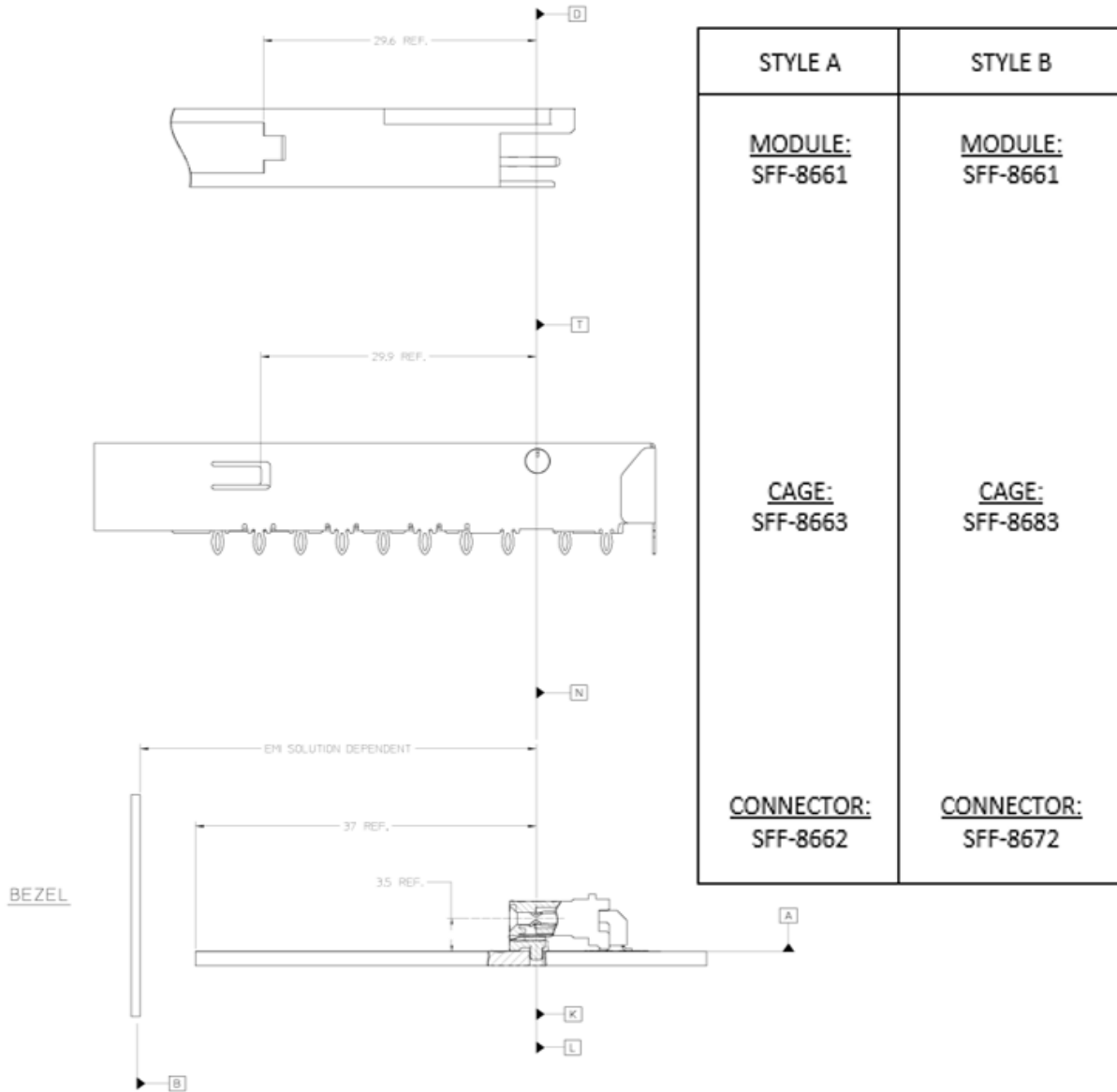

FIGURE 4-1 DATUM DEFINITIONS

TABLE 4-1 DATUM DESCRIPTIONS

Datum	Description	Reference
A	Host board top surface	See Figure 4-1
C	Distance between connector housing pegs on host board	See Figure 5-3
G	Width of module PC board	See Figure 5-1
H	Leading edge of signal contact pads on module PC board	See Figure 5-1
J	Top surface of module PC board	See Figure 5-1
K	Host board thru hole #1 to accept connector guide post	See Figure 4-1
L	Host board thru hole #2 to accept connector guide post	See Figure 4-1
N	Connector alignment post	See Figure 4-1
AA	Connector slot width	See Figure 5-2

5. Connector Dimensions

The dimensioning convention are described in ANSI-Y14-5M, Dimensioning and Tolerancing. All dimensions are in millimeters.

Dimension related requirements for the connector system addressed in this specification are specified in the tables and figures in this clause

5.1 Free (Module) Paddle Card

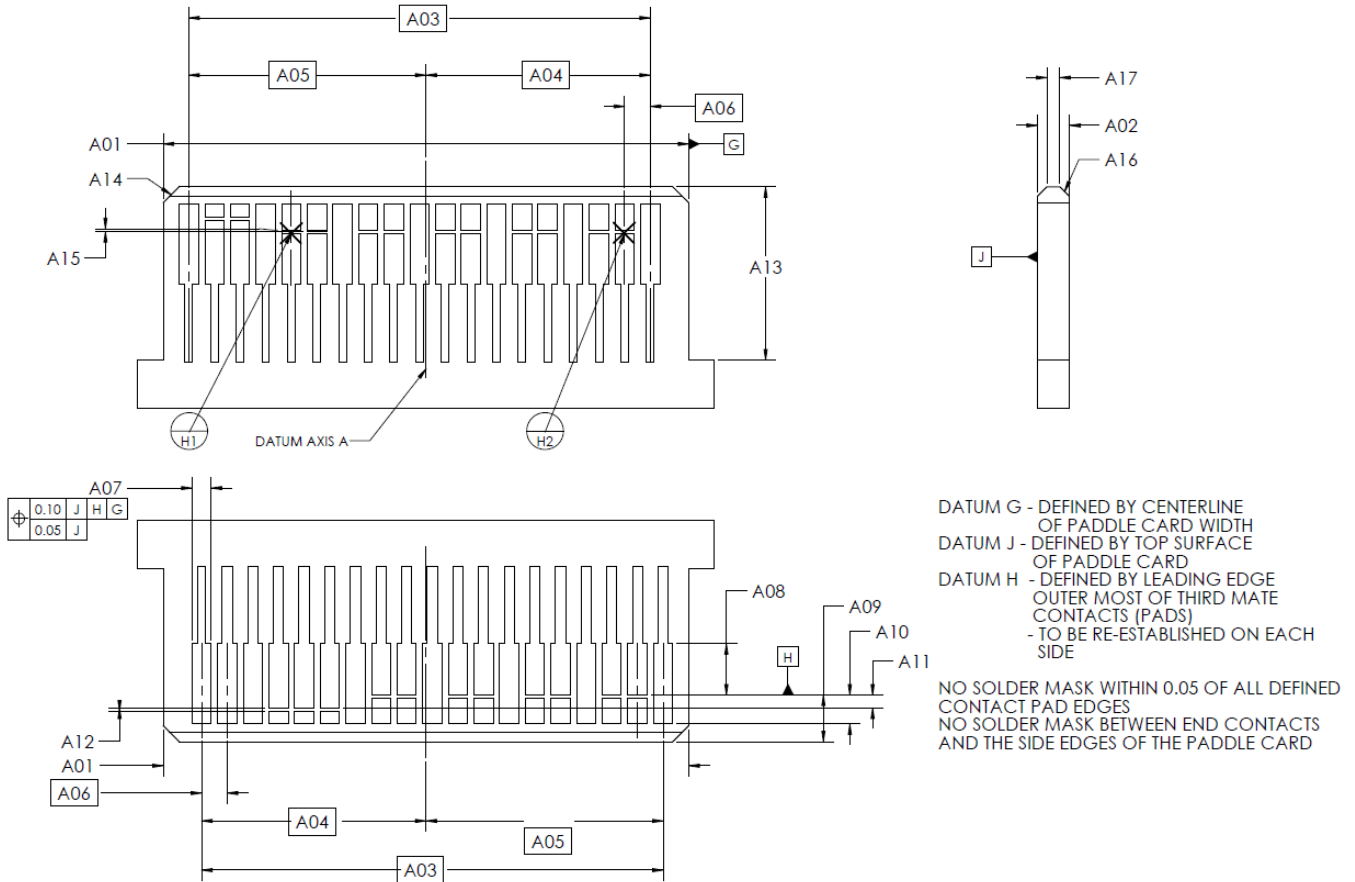

FIGURE 5-1 FREE (MODULE) PADDLE CARD

TABLE 5-1 FREE (MODULE) PADDLE CARD DIMENSIONS

Designator	Description	Dimension	Tolerance
A01 (*)	Paddle Card Width	16.42	+/- 0.08
	Paddle Card Width (SFF-8436)	16.40	+/- 0.10
A02	Paddle Card Thickness (across pads)	1.00	+/- 0.10
A03	First to Last Pad Centers	14.40	Basic
A04	Card Center to Outer Pad Center	7.00	Basic
A05	Card Center to Outer Pad Center	7.40	Basic
A06	Pad Center to Center (Pitch)	0.80	Basic
A07 (*)	Pad Width (16.42 Paddle Card Width)	0.54	+/- 0.04
	Pad Width (16.40 Paddle Card Width)	0.60	+/- 0.03
A08	Pad Length - Third Mate	1.6	Min.
A09	Card Edge to Third Mate Pad	1.45	+/- 0.10
A10	Third Mate to First Mate	0.90	+/- 0.05
A11	Third Mate to Second Mate	0.40	+/- 0.05
A12	Pad to Pre-Pad	0.10	+/- 0.03
A13	Component Keep Out Area	5.40	Min.
A14	Lead-in Chamfer x 45 degrees	0.50	+/- 0.10
A15	Third Mate Pad to Datum C	0.00	+/- 0.03
A16	Lead-in Chamfer x 45 degrees	0.30	+/- 0.10
A17	Lead-in Flat	0.40	Ref
(*) Note: Dimensions of the Pad Width and the Paddle Card Width are such that the centerline of the terminal does not go off the edge of the pad.			

5.2 Fixed (Receptacle) Right Angle Connector

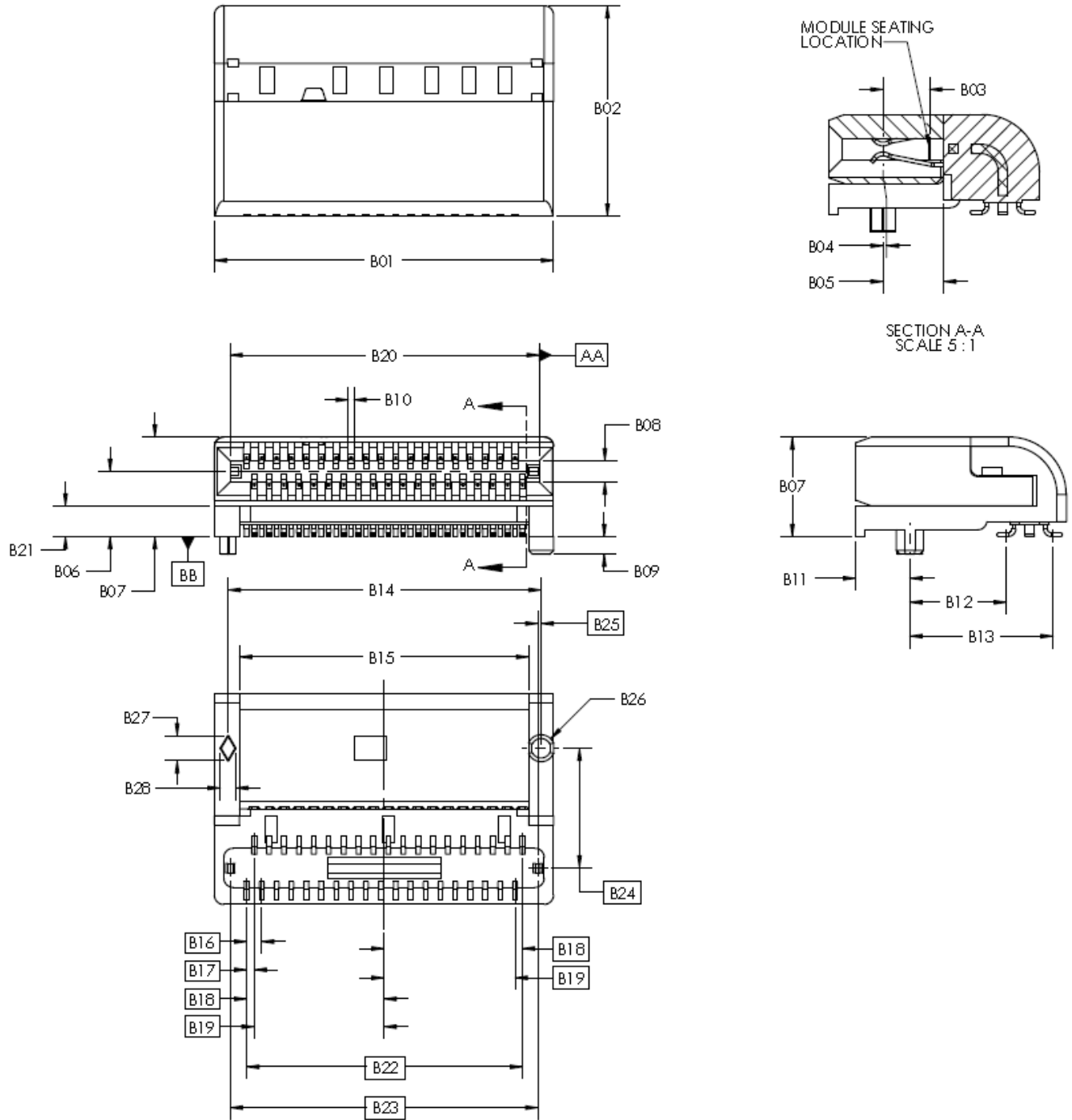

FIGURE 5-2 FIXED (RECEPTACLE) RIGHT ANGLE CONNECTOR

TABLE 5-2 FIXED (RECEPTACLE) RIGHT ANGLE CONNECTOR DIMENSIONS

Designator	Description	Dimension	Tolerance
B01	Receptacle Width	18.2	+/- 0.10
B02	Receptacle Length	11.3	+0.33/-0.13
B03	Module Seating Location	2.5	Ref
B04	Peg to Contact Centerline	0.00	+/- 0.10
B05	Card Slot Depth	3.25	Min
B06	PCB to Card Slot Centerline	3.5	+/- 0.10
B07	Overall Height	5.35	+/- 0.13
B08	Card Slot Height	1.14	Min
B09	Peg Length	0.95	+/- 0.13
B10 (*)	Contact Zone (0.18 wide terminal)	0.3	Max
	Contact Zone (0.20 wide terminal)	0.32	Max
	Contact Zone (0.22 wide terminal)	0.34	Max
	Contact Zone (0.25 wide terminal)	0.37	Max
B11	Front Face to Peg	2.90	Basic
B12	Peg to Row A	5.18	+/- 0.10
B13	Peg to Row B	7.69	+/- 0.10
B14	Peg to Peg	16.8	Basic
B15	Leg to Leg	15.53	+/- 0.13
B16	Contact Pitch (within Row)	0.8	Basic
B17	Contact Pitch (Row to Row)	0.4	Basic
B18	Centerline to Last Contact	7.4	Basic
B19	Centerline to First Contact	7.0	Basic
B20	Card Slot Width	16.6	+/- 0.05
B21	Height under Receptacle	1.65	+/- 0.08
B22	First to Last Contact	14.8	Basic
B23	Ground Tab to Ground Tab	16.53	Basic
B24	Locating Post to Ground Tab (Y)	6.42	Basic
B25	Locating Post to Ground Tab (X)	0.18	Basic
B26	Peg Diameter	1.45	+/- 0.05
B27	Diamond peg height	1.45	+/- 0.05
B28	Diamond peg width	0.85	+/- 0.10

(*) Note: Contact Zone is defined as a zone with its centerline located at the theoretical contact centerline and the contact must always be completely located within it.

5.3 Fixed (Receptacle) Right Angle Connector Footprint

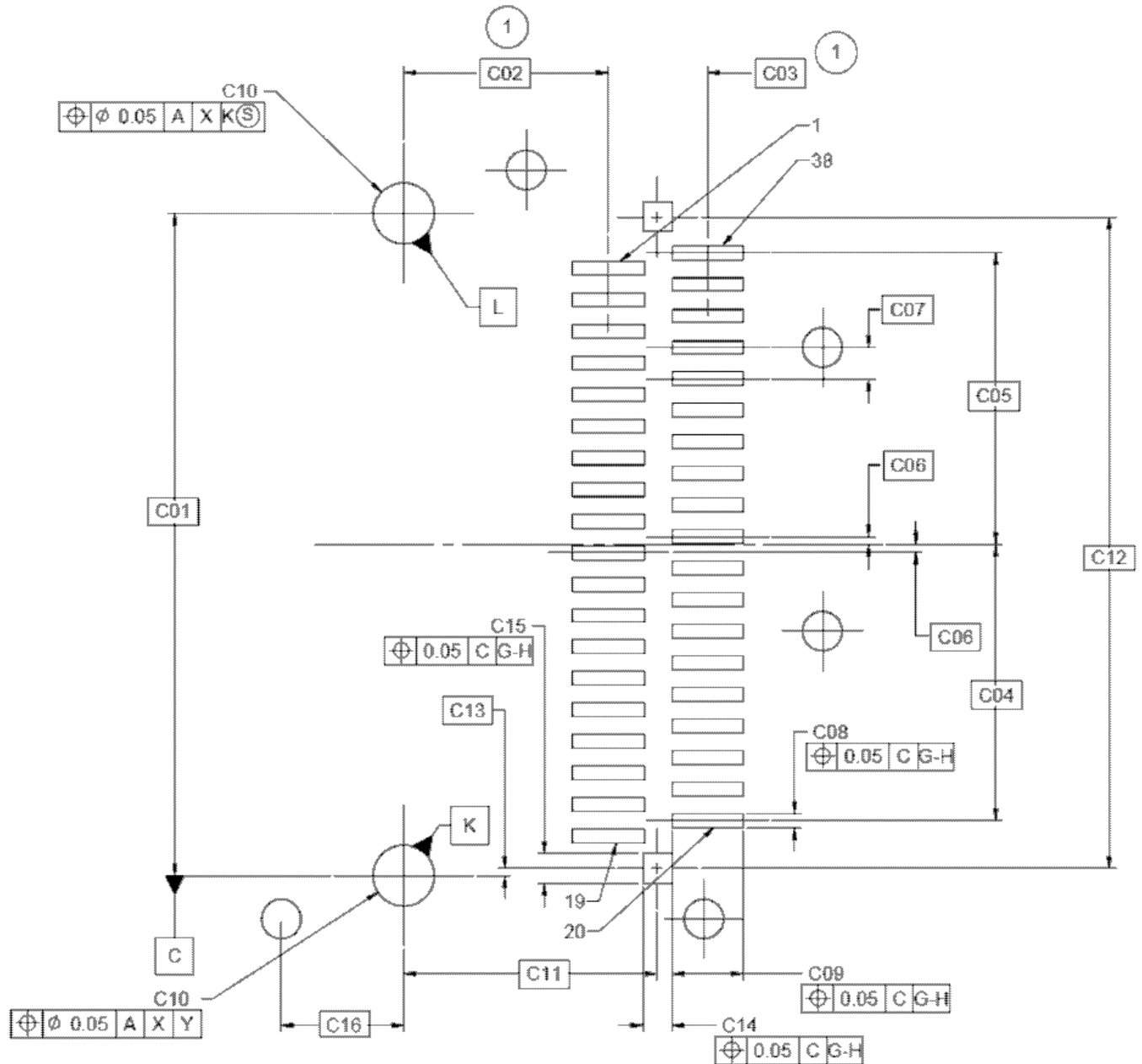

- NOTES:
1. DIMENSION TO CENTERLINE OF PAD.
 2. DATUM X AND Y ARE ESTABLISHED BY THE CUSTOMER FIDUCIAL.
 3. FOR COMPONENT AND TRACE KEEP-OUT AREA REFER TO SFF-8436

FIGURE 5-3 FIXED (RECEPTACLE) RIGHT ANGLE CONNECTOR FOOTPRINT

TABLE 5-3 FIXED (RECEPTACLE) RIGHT ANGLE CONNECTOR FOOTPRINT DIMENSIONS

Designator	Description	Dimension	Tolerance
C01	Locating Hole to Locating Hole	16.80	Basic
C02	Locating Hole to Row A	5.18	Basic
C03	Row A to Row B	2.51	Basic
C04	Card Center to Outer Pad Center	7.00	Basic
C05	Card Center to Outer Pad Center	7.40	Basic
C06	Card Center to Inner Pad Center	0.20	Basic
C07	Pad Pitch	0.80	Basic
C08	Pad Width	0.35	+/- 0.03
C09	Pad Length	1.80	+/- 0.03
C10	Locating Hole Diameter	1.55	+/- 0.05
C11	Locating Hole to Ground Pad	6.42	Basic
C12	Grounding Pad to Grounding Pad	16.53	Basic
C13	Locating Hole to Grounding Pad	0.18	Basic
C14	Grounding Pad Width	0.75	+/- 0.05
C15	Grounding Pad Length	0.75	+/- 0.05
C16	Locating hole to cage hole	3.10	Basic

6. Connector Performance Requirements

The connector conforms to the test sequence as defined in EIA-364 TS-1000.

The following tables define the performance criteria and test procedures for those test sequences.

TABLE 6-1 TS-1000 TEST PARAMETERS AND CRITERIA

Test Parameter	Criteria
Durability	Pre-condition: 25 cycles Group 7: 100 cycles
Field Life (3, 5, 7, or 10 years)	10 years
Field Temperature (57, 60, 65, 75, or 85C)	65 degrees C
Test Group 4 Option	Manufacturer to specify
Plating Type	Precious
Surface Treatment	Manufacturer to specify

TABLE 6-2 ELECTRICAL TEST PARAMETERS AND CRITERIA

Parameter	Test Condition	Specification
Current	EIA 364-70 30 degree C temperature rise	-Signal contacts: 0.5 A per contact MAX -Designated power contact: 1.0 A per contact MAX
Low Level Contact Resistance	EIA 364-23 20 mVDC, 100 mA	20 mOhm deviation from initial (baseline) contact resistance
Insulation Resistance	EIA 364-21 100 VDC between adjacent contacts	1000M ohms minimum Between adjacent contacts
Dielectric Withstanding Voltage	EIA 364-20 300 VDC minimum for 1 minute between adjacent contacts	No defect or breakdown between adjacent contacts
Vibration	EIA 364-28	-No damage -No discontinuity longer than 1 microsecond allowed -20 mOhm MAX change from initial (baseline) contact resistance
Mechanical Shock	EIA 364-27	-No damage -20 mOhm MAX change from initial (baseline) contact resistance
Differential Impedance (connector area)	EIA 364-108 Rise time: 9.6ps (20-80%) Includes host board interface, connector and card interface.	For Reference Only 90-110 ohms (distribution) 100+/-5 ohms (distribution of average value)
Within Pair Skew	EIA 364-103	2ps maximum (By design)
Near End Isolation Loss	EIA 364-90 50 MHz to 14 GHz	45 dB minimum
Insertion Loss	EIA 364-101 50 MHz to 14 GHz	1.0 dB maximum
Return Loss	EIA 364-108 50 MHz to 14 GHz	12.0 dB minimum
Differential to Common Mode Through Conversion Loss	50 MHz to 14 GHz	-24.0 dB maximum
Far End Isolation Loss	EIA 364-90 50 MHz to 14 GHz	40.0 dB maximum
*1 Rating on designated power pins is 1.0 A per contact (Vcc T, Vcc R, and Vcc 1) Note: Testing is as per recommendations of OIF (Optical Internet Forum)		

TABLE 6-3 MECHANICAL PERFORMANCE REQUIREMENT

Parameter	Test Condition	Specification¹
Insertion Force	EIA 364-13 Test with connector, cage & module (latch disengaged, without heat sink)	60N MAX
Extraction Force	EIA 364-13 Test with connector, cage & module (latch disengaged, without heat sink)	30N MAX
Contact Normal Force	Manufacturer specified test to evaluate the normal force applied by a single contact	0.5N MIN
Connector/ Cage Durability	EIA 364-09 Test with connector, cage & module ²	100 cycles MIN
Module Durability	EIA 364-09 Test with connector, cage & module	50 cycles MIN
<p>NOTES:</p> <ol style="list-style-type: none"> In addition to the requirements listed, all parts must be free of visible damage after testing. Modules may be replaced every 50 cycles. 		

TABLE 6-4 ENVIRONMENTAL PERFORMANCE REQUIREMENT

Parameter	Specification
Storage Temperature	-20C to + 85C
Humidity	80%