

SFF specifications are available at <http://www.snia.org/sff/specifications>
or <ftp://ftp.seagate.com/sff>

This specification was developed by the SFF Committee prior to it becoming the SFF TA (Technology Affiliate) TWG (Technical Working Group) of SNIA (Storage Networking Industry Association).

The information below should be used instead of the equivalent herein.

POINTS OF CONTACT:

Chairman SFF TA TWG
Email: SFF-Chair@snia.org

If you are interested in participating in the activities of the SFF TWG, the membership application can be found at:

<http://www.snia.org/sff/join>

The complete list of SFF Specifications which have been completed or are currently being worked on can be found at:

<http://www.snia.org/sff/specifications/SFF-8000.TXT>

The operations which complement the SNIA's TWG Policies & Procedures to guide the SFF TWG can be found at:

<http://www.snia.org/sff/specifications/SFF-8032.PDF>

Suggestions for improvement of this specification will be welcome, they should be submitted to:

<http://www.snia.org/feedback>

SFF Committee documentation may be purchased in electronic form.
SFF specifications are available at <ftp://ftp.seagate.com/sff>

SFF Committee

SFF-8648

Specification for

Mini Multilane 12X 28 Gb/s Shielded Cage/Connector (CXP28)

Rev 1.0 May 15, 2014

Secretariat: SFF Committee

Abstract: This specification defines the physical interface and general performance requirements for the Mini Multilane Shielded Integrated Connector, which is designed for use in high speed serial, interconnect applications at multigigabit speeds.

This specification provides a common reference for systems manufacturers, system integrators, and suppliers. This is an internal working specification of the SFF Committee, an industry ad hoc group.

This specification is made available for public review, and written comments are solicited from readers. Comments received by the members will be considered for inclusion in future revisions of this specification.

The description of a connector in this specification does not assure that the specific component is actually available from connector suppliers. If such a connector is supplied it must comply with this specification to achieve interoperability between suppliers.

Support: This specification is supported by the identified member companies of the SFF Committee.

POINTS OF CONTACT:

Jay Neer
Technical Editor
Molex
2222 Wellington Court
Lisle, IL 60532
Ph: 561-447-2907 x555-3889
Email: jay.neer_at_molex_dot_com

I. Dal Allan
Chairman SFF Committee
14426 Black Walnut Court
Saratoga, CA 95070
Ph: 408-867-6630
Email: endlcom_at_acm_dot_org

EXPRESSION OF SUPPORT BY MANUFACTURERS

The following member companies of the SFF Committee voted in favor of this industry specification.

GLGnet Electronics
Hewlett Packard
Molex
Shinning Electronics
TE Connectivity

The following member companies of the SFF Committee voted against this industry specification.

Amphenol
FCI
Foxconn

The following member companies of the SFF Committee voted to abstain on this industry specification.

Broadcom
EMC
Finisar
HGST
IBM
JDS Uniphase
QLogic
Seagate
Sumitomo

Change History

Rev 0.8

- Restructured to reduce content which duplicates other speed variations.

Rev 0.9

- Removed IP statement on p2 as not appropriate in a reference specification.

Rev 1.0

- Rev 1.0 - Title change for commonality in style with QSFP

Foreword

The development work on this specification was done by the SFF Committee, an industry group. The membership of the committee since its formation in August 1990 has included a mix of companies which are leaders across the industry.

When 2 1/2" diameter disk drives were introduced, there was no commonality on external dimensions e.g. physical size, mounting locations, connector type, connector location, between vendors.

The first use of these disk drives was in specific applications such as laptop portable computers and system integrators worked individually with vendors to develop the packaging. The result was wide diversity, and incompatibility.

The problems faced by integrators, device suppliers, and component suppliers led to the formation of the SFF Committee as an industry ad hoc group to address the marketing and engineering considerations of the emerging new technology.

During the development of the form factor definitions, other activities were suggested because participants in the SFF Committee faced more problems than the physical form factors of disk drives. In November 1992, the charter was expanded to address any issues of general interest and concern to the storage industry. The SFF Committee became a forum for resolving industry issues that are either not addressed by the standards process or need an immediate solution.

Those companies which have agreed to support a specification are identified in the first pages of each SFF Specification. Industry consensus is not an essential requirement to publish an SFF Specification because it is recognized that in an emerging product area, there is room for more than one approach. By making the documentation on competing proposals available, an integrator can examine the alternatives available and select the product that is felt to be most suitable.

SFF Committee meetings are held during T10 weeks (see www.t10.org), and Specific Subject Working Groups are held at the convenience of the participants. Material presented at SFF Committee meetings becomes public domain, and there are no restrictions on the open mailing of material presented at committee meetings.

Most of the specifications developed by the SFF Committee have either been incorporated into standards or adopted as standards by EIA (Electronic Industries Association), ANSI (American National Standards Institute) and IEC (International Electrotechnical Commission).

If you are interested in participating or wish to follow the activities of the SFF Committee, the sign up for membership and/or documentation can be found at:
www.sffcommittee.com/ie/join.html

The complete list of SFF Specifications which have been completed or are currently being worked on by the SFF Committee can be found at:
<ftp://ftp.seagate.com/sff/SFF-8000.TXT>

If you wish to know more about the SFF Committee, the principles which guide the activities can be found at:
<ftp://ftp.seagate.com/sff/SFF-8032.TXT>

Suggestions for improvement of this specification will be welcome. They should be sent to the SFF Committee, 14426 Black Walnut Ct, Saratoga, CA 95070.

TABLE OF CONTENTS

1	Scope	5
1.1	Application Specific Criteria	5
2	References	5
2.1	Industry Documents	5
2.2	SFF Specifications	5
2.3	Sources	5
2.4	Conventions	5
3	General Description	6
4	Overview of Referenced Specifications	6
4.1	Application Requirements	6
4.2	SFF-8617	6

FIGURES

Figure 3-1	Documentation to Implement a 28 Gb/s Connector	6
Figure 4-1	General View Of A Shielded Integrated Connector	6

SFF Committee --

Mini Multilane 12X 28 Gb/s Shielded Cage/Connector (CXP28)

1 Scope

This specification defines the plug, guide/strain relief shell, and latching requirements for the Mini Multilane Shielded Integrated Connector based upon the mating interface defined herein.

1.1 Application Specific Criteria

This connector is capable of meeting the interface requirements for the operation of:

- IEEE 802.3bj 100 Gb/s Ethernet
- IEEE 802.3bm 100 Gb/s Ethernet
- InfiniBand IBTA EDR

2 References

2.1 Industry Documents

- IEEE 802.3bj 100 Gb/s Ethernet
- IEEE 802.3bm 100 Gb/s Ethernet
- InfiniBand Architecture Specifications FDR and EDR
- SFF-8410 High Speed Serial Testing for Copper Links
- SFF-8617 Mini Multilane 12X Shielded Cage/Connector

2.2 SFF Specifications

There are several projects active within the SFF Committee. The complete list of specifications which have been completed or are still being worked on are listed in the specification at <ftp://ftp.seagate.com/sff/SFF-8000.TXT>

2.3 Sources

Those who join the SFF Committee as an Observer or Member receive electronic copies of the minutes and SFF specifications (<http://www.sffcommittee.com/ie/join.html>).

Copies of ANSI standards may be purchased from the InterNational Committee for Information Technology Standards (<http://www.techstreet.com/incitsgate.tmpl>).

2.4 Conventions

The dimensioning conventions are described in ANSI-Y14.5M, Geometric Dimensioning and Tolerancing. All dimensions are in millimeters.

The ISO convention of numbering is used i.e., the thousands and higher multiples are separated by a space and a period is used as the decimal point. This is equivalent to the English/American convention of a comma and a period.

American	French	ISO
0.6	0,6	0.6
1,000	1 000	1 000
1,323,462.9	1 323 462,9	1 323 462.9

3 General Description

This specification identifies the documentation required to implement a 12 Channel Multilane connector suitable to the using applications, as illustrated in the following pictorial representation.

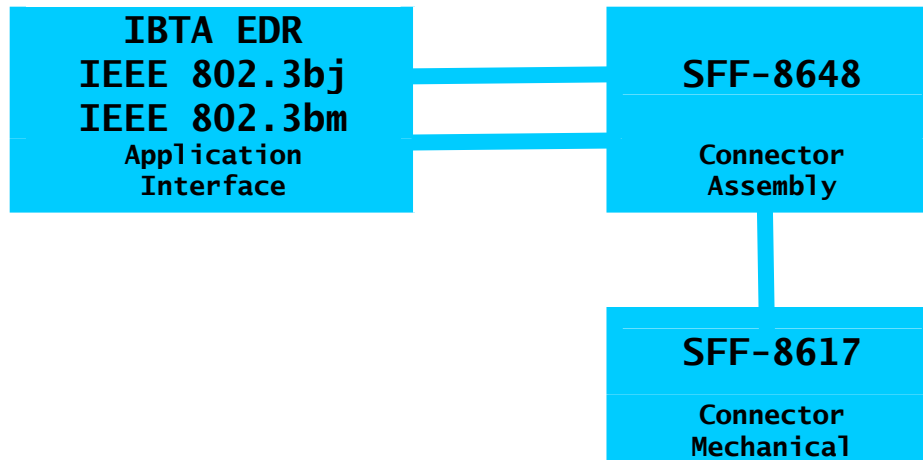

FIGURE 3-1 DOCUMENTATION TO IMPLEMENT A 28 GB/S CONNECTOR

4 Overview of Referenced Specifications

4.1 Application Requirements

The electrical and EMI considerations for the use of this connector are specified by the using standards listed in Section 1.1

4.2 SFF-8617

The mechanical dimensioning of this specification provides mechanical compatibility between generations of various speeds.

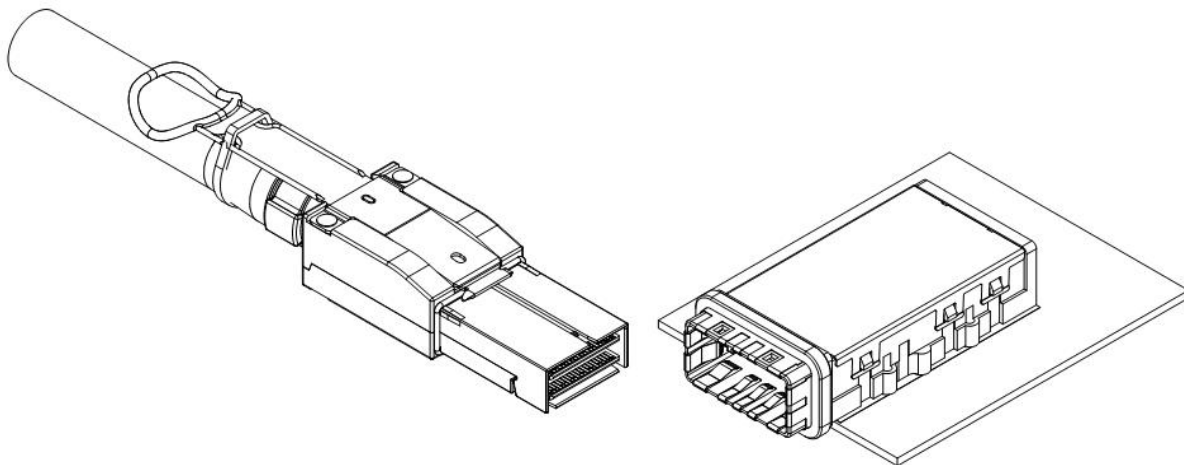

FIGURE 4-1 GENERAL VIEW OF A SHIELDED INTEGRATED CONNECTOR

The mechanical representation of this connector looks the same between generations, however, there may have been changes to the internal design which enable it to perform at the characteristics required of the new applications.

Connectors manufactured to meet these applications can be expected to perform

satisfactorily in systems designed for previous generations of lower speed systems, but it is not typically anticipated that they will be able to meet the needs of next generation systems that require higher data rates.