

SFF specifications are available at <http://www.snia.org/sff/specifications>  
or <ftp://ftp.seagate.com/sff>

**This specification was developed by the SFF Committee prior to it becoming the SFF TA (Technology Affiliate) TWG (Technical Working Group) of SNIA (Storage Networking Industry Association).**

The information below should be used instead of the equivalent herein.

POINTS OF CONTACT:

Chairman SFF TA TWG  
Email: [SFF-Chair@snia.org](mailto:SFF-Chair@snia.org)

If you are interested in participating in the activities of the SFF TWG, the membership application can be found at:

<http://www.snia.org/sff/join>

The complete list of SFF Specifications which have been completed or are currently being worked on can be found at:

<http://www.snia.org/sff/specifications/SFF-8000.TXT>

The operations which complement the SNIA's TWG Policies & Procedures to guide the SFF TWG can be found at:

<http://www.snia.org/sff/specifications/SFF-8032.PDF>

Suggestions for improvement of this specification will be welcome, they should be submitted to:

<http://www.snia.org/feedback>

SFF Committee documentation may be purchased in hard copy or electronic form.  
SFF specifications are available at <ftp://ftp.seagate.com/sff>

SFF Committee

**SFF-8552 Specification for**

**Form Factor of 5 1/4" 9.5mm and 12.7mm Height Optical Drives**

Rev 1.4    October 20, 2008

Secretariat: SFF Committee

Abstract: This specification defines the dimensions for 5 1/4" 9.5mm and 12.7mm height optical drives.

This document provides a common specification for systems manufacturers, system integrators, and suppliers of optical drives. This is an internal working document of the SFF Committee, an industry ad hoc group.

This specification is made available for public review, and written comments are solicited from readers. Comments received by the members will be considered for inclusion in future revisions of this document.

Support: This specification is supported by the identified member companies of the SFF Committee.

POINTS OF CONTACT:

Tim Mostad  
VTM, Inc  
3855 SW 153<sup>rd</sup> Drive  
Beaverton OR 97006

Ph: 503-619-0505  
Email: [tmostad@vtm-inc.com](mailto:tmostad@vtm-inc.com)

I. Dal Allan  
Chairman SFF Committee  
14426 Black Walnut Court  
Saratoga CA 95070

Ph: 408-867-6630  
[endlcom@acm.org](mailto:endlcom@acm.org)

**EXPRESSION OF SUPPORT BY MANUFACTURERS**

The following member companies of the SFF Committee voted in favor of this industry specification.

Amphenol  
Dell  
EMC  
ENDL  
Hitachi GST  
Intel  
Unisys

The following SFF member companies voted no on the technical content of this industry specification.

All Best Technique  
Panasonic  
Pioneer NewMedia

The following member companies of the SFF Committee voted to abstain on this industry specification.

Adaptec  
AMCC  
ETRI  
FCI  
Finisar  
Foxconn  
Fujitsu CPA  
Hewlett Packard  
IBM  
Infineon  
LSI  
Maxtor  
Molex  
Seagate  
Sun Microsystems  
TE Connectivity  
Toshiba America  
Vitesse Semiconductor

## TABLE OF CONTENTS

1.	Scope	6
1.1	Description of Clauses	6
2.	References	6
2.1	Industry Documents	6
2.2	SFF Specifications	7
2.3	Sources	7
3.	General Description	7
4.	Definitions and Conventions	7
4.1	Definitions	7
4.1.1	Datum A	7
4.1.2	Datum B	7
4.1.3	Optional	7
4.1.4	PATA	7
4.1.5	PUM	7
4.1.6	SATA	7
4.2	Conventions	7
5.	5 1/4" 9.5mm Height Optical Drive PATA Form Factor	9
6.	5 1/4" 12.7mm Height Optical Drive PATA Form Factor	12
7.	Optional 12.7mm Height Optical Bezel Attachment Specification	16
7.1	Content	16
7.2.	Purpose/Objective	16
7.3.	Bezel Side Specifications	16
7.3.1	Bezel Alignment Pin	16
7.3.1.1	Alignment Pin Dimensions	16
7.3.1.2	Location Of Alignment Pin	17
7.3.2	Bezel Snap Number 1 Definition	18
7.3.2.1	Snap Dimensions	18
7.3.2.2	Location Of Snap	19
7.3.3	Bezel Snap Number 2 Definition	20
7.3.3.1	Snap Dimensions	20
7.3.3.2	Location Of Snap	21
7.3.4	Bezel Snap Number 3 Definition	22
7.3.4.1	Snap Dimensions	22
7.3.4.2	Location Of Snap	23
7.3.5	Bezel Snap Number 4 Definition	24
7.3.5.1	Snap Dimensions	24
7.3.5.2	Location Of Snap	25
7.3.6	Datum A Definition	25
7.3.6.1	Implementers Note	25
7.3.7	Switch and Led	26
7.3.7.1	Location Of Switch and Led	26
7.3.7.2	Switch Position/Activation Points	27
7.3.7.3	Led Position	28
7.3.8	Emergency Eject	28
7.3.8.1	Emergency Eject Hole Location	28
7.3.8.2	Emergency Eject Tube	28
7.3.9	Clearance For Pickup Unit Module (PUM)	29
7.3.9.1	Location Of Recessed Area	29
7.3.10	Acoustic Noise Pad (Optional)	29
7.3.10.1	Acoustic Noise Pad Location	29
7.3.10.2	Material Requirements	30
7.4.	Tray Side Specifications	30
7.4.1	Grounding Touch Point	30
7.4.2	Tray Datum Definition	30
7.4.2.1	Tray Protrusion	30
7.4.3	Rib Touch Points	31
7.4.3.1	Position Of Touch Points	31
7.4.4	Alignment Pin Hole	31
7.4.4.1	Dimensions Of Alignment Pin Hole	31
7.5.	Implementers Guide	31
7.5.1	Bezel Roll Off Prevention	31
7.6	Clause 7 Revision History	32
8.	Optional 12.7mm Height Optical Bezel Attachment Specification	33
8.1	Content	33
8.2.	Purpose/Objective	33

8.3.	Bezel Side Specifications	33
8.3.1	Bezel Alignment Pin	33
8.3.1.1	Alignment Pin Dimensions	33
8.3.1.2	Location Of Alignment Pin	34
8.3.2	Bezel Snap Number 1 Definition	35
8.3.2.1	Snap Dimensions	35
8.3.2.2	Location Of Snap	36
8.3.3	Bezel Snap Number 2 Definition	37
8.3.3.1	Snap Dimensions	37
8.3.3.2	Location Of Snap	38
8.3.4	Bezel Snap Number 3 Definition	39
8.3.4.1	Snap Dimensions	39
8.3.4.2	Location Of Snap	40
8.3.5	Bezel Snap Number 4 Definition	41
8.3.5.1	Snap Dimensions	41
8.3.5.2	Location Of Snap	42
8.3.6	Datum A Definition	42
8.3.6.1	Implementers Note	42
8.3.7	Button and Led	43
8.3.7.1	Location Of Button and Led	43
8.3.7.3	Led Position	43
8.3.8	Emergency Eject	44
8.3.8.1	Emergency Eject Hole Location	44
8.3.8.2	Emergency Eject Tube	44
8.3.9	Clearance For Pickup Unit Module (PUM)	45
8.3.9.1	Location Of Recessed Area	45
8.3.10	Acoustic Noise Pad (Optional)	45
8.3.10.1	Acoustic Noise Pad Location	45
8.3.10.2	Material Requirements	46
8.4.	Tray Side Specifications	46
8.4.1	Grounding Touch Point	46
8.4.2	Tray Datum Definition	46
8.4.2.1	Tray Protrusion	47
8.4.3	Rib Touch Points	47
8.4.3.1	Position Of Touch Points	47
8.4.4	Alignment Pin Hole	47
8.4.4.1	Dimensions Of Alignment Pin Hole	47
8.5.	Implementers Guide	48
8.5.1	Bezel Roll Off Prevention	48

**Foreword**

The development work on this specification was done by the SFF Committee, an industry group. The membership of the committee since its formation in August 1990 has included a mix of companies which are leaders across the industry.

When 2 1/2" diameter disk drives were introduced, there was no commonality on external dimensions e.g. physical size, mounting locations, connector type, connector location, between vendors.

The first use of these disk drives was in specific applications such as laptop portable computers and system integrators worked individually with vendors to develop the packaging. The result was wide diversity, and incompatibility.

The problems faced by integrators, device suppliers, and component suppliers led to the formation of the SFF Committee as an industry ad hoc group to address the marketing and engineering considerations of the emerging new technology.

During the development of the form factor definitions, other activities were suggested because participants in the SFF Committee faced more problems than the physical form factors of disk drives. In November 1992, the charter was expanded to address any issues of general interest and concern to the storage industry. The SFF Committee became a forum for resolving industry issues that are either not addressed by the standards process or need an immediate solution.

Those companies which have agreed to support a specification are identified in the first pages of each SFF Specification. Industry consensus is not an essential requirement to publish an SFF Specification because it is recognized that in an emerging product area, there is room for more than one approach. By making the documentation on competing proposals available, an integrator can examine the alternatives available and select the product that is felt to be most suitable.

SFF Committee meetings are held during T10 weeks (see [www.t10.org](http://www.t10.org)), and Specific Subject Working Groups are held at the convenience of the participants. Material presented at SFF Committee meetings becomes public domain, and there are no restrictions on the open mailing of material presented at committee meetings.

Most of the specifications developed by the SFF Committee have either been incorporated into standards or adopted as standards by EIA (Electronic Industries Association), ANSI (American National Standards Institute) and IEC (International Electrotechnical Commission).

If you are interested in participating or wish to follow the activities of the SFF Committee, the signup for membership and/or documentation can be found at:

[www.sffcommittee.com/ie/join.html](http://www.sffcommittee.com/ie/join.html)

The complete list of SFF Specifications which have been completed or are currently being worked on by the SFF Committee can be found at:

<ftp://ftp.seagate.com/sff/SFF-8000.TXT>

If you wish to know more about the SFF Committee, the principles which guide the activities can be found at:

<ftp://ftp.seagate.com/sff/SFF-8032.TXT>

Suggestions for improvement of this specification will be welcome. They should be sent to the SFF Committee, 14426 Black Walnut Ct, Saratoga, CA 95070.

SFF Committee --

## Form Factor of 5 1/4" 9.5mm and 12.7mm Height Optical Drives

### 1. Scope

SFF-8552 defines the configuration characteristics associated with 9.5mm and 12.7mm Height 5 1/4" Optical Drives. *Note: By naming convention, the 5 1/4" width dimension is used however these drives are actually closer to 5" wide but use the same media as 5 1/4" drives.*

The purpose of the 85xx suite is to define the external characteristics of drives such that products from different vendors may be used in the same mounting configurations.

The set of specifications provide external dimensions, connectors, connector placement, mounting holes and interface pin outs to assist manufacturers in the systems integration of small form factor drives.

- SFF-8500 contains general information regarding connector space, mounting considerations and measurement requirements.
- SFF-8501 defines the dimensions of 5 1/4" disk drives.
- SFF-8551 defines the dimensions of 5 1/4" CD-ROM drives.
- SFF-8552 contains information on the mechanical form factor of 5 1/4" 9.5mm and 12.7mm height drives including dimensions, connector location, and mounting considerations
- Other specifications in the 85xx family define the location of connectors on 5 1/4" drives.

In an effort to broaden the applications for storage products, an ad hoc industry group of companies representing system integrators, peripheral suppliers, and component suppliers decided to address issues which appear in the marketplace that affect many OEMs and vendors.

The SFF Committee was formed in August, 1990 to broaden the applications for storage devices, and is an ad hoc industry group of companies representing system integrators, peripheral suppliers, and component suppliers.

#### 1.1 Description of Clauses

Clause 1 contains the Scope and Purpose.

Clause 2 contains Referenced and Related Standards and SFF Specifications.

Clause 3 contains the General Description.

Clause 4 contains the Definitions and Conventions

Clause 5 contains the 5 1/4" 9.5mm Height Optical Drive PATA Form Factor

Clause 6 contains the 5 1/4" 12.7mm Height Optical Drive PATA Form Factor

Clause 7 contains the optional recommended 12.7mm Height Bezel Attach Specification

### 2. References

The SFF Committee activities support the requirements of the storage industry, and it is involved with several standards.

#### 2.1 Industry Documents

The following interface standards are relevant to many SFF Specifications.

- X3.221-1995 ATA (AT Attachment) and subsequent extensions
- X3T10/0948 ATA-2 (ATA Extensions)

## 2.2 SFF Specifications

There are several projects active within the SFF Committee. The complete list of specifications which have been completed or are still being worked on are listed in the specification at <ftp://ftp.seagate.com/sff/SFF-8000.TXT>

## 2.3 Sources

Those who join the SFF Committee as an Observer or Member receive electronic copies of the minutes and SFF specifications (<http://www.sffcommittee.com/ie/join.html>).

Copies of ANSI standards may be purchased from the InterNational Committee for Information Technology Standards (<http://tinyurl.com/c4psg>).

Copies of SFF, T10 (SCSI), T11 (Fibre Channel) and T13 (ATA) standards and standards still in development are available on the HPE version of CD\_Access (<http://tinyurl.com/85fts>).

## 3. General Description

The application environment for the 5 1/4" 9.5mm / 12.7mm Height (slimline) Optical Drive Form Factors is any computer, cabinet, or enclosure connecting to one or more drives in a restricted packaging environment. Slimline Optical Drives are widely-used where low power and small size are important configuration parameters.

This specification defines the dimensions, mounting considerations, and connector location for slimline optical drives. The purpose of an SFF Specification is to provide information that will assist vendors to design products that can fit the same packaging envelope.

## 4. Definitions and Conventions

### 4.1 Definitions

For the purpose of SFF Specifications, the following definitions apply:

- 4.1.1 Datum A: Datum A refers to the back plane of the bezel on a cored as well as flat bezel. This is the side of the bezel that shall make contact with the tray. This specification refers to and defines the Datums in figures throughout the document. Datum A is also defined on the Features that are on the bezel (snaps). This Datum and the Datums defined on the bezels are coincident.
- 4.1.2 Datum B: Datum B refers to the front surface of the tray. This surface makes contact with the bezel. Datum B is defined in section 7.4.2 with Figure 7.16.
- 4.1.3 Optional: This term describes features which are not required by the SFF Specification. However, if any feature defined by the SFF Specification is implemented, it shall be done in the same way as defined by the Specification.
- 4.1.4 PATA (Parallel AT Attachment) describes a device with built-in ATA protocol electronics. Also referred to as IDE (Integrated Drive Electronics).
- 4.1.5 PUM: Pickup Assembly Module or Traverse Assembly.
- 4.1.6 SATA (Serial AT Attachment) describes a device with built-in SATA protocol electronics.

### 4.2 Conventions

If there is a conflict between text and tables on a feature described as optional, the table shall be accepted as being correct.

Certain terms used herein are the proper names of signals. These are printed in uppercase to avoid possible confusion with other uses of the same words; e.g.,



ATTENTION. Any lower-case uses of these words have the normal American-English meaning.

A number of conditions, commands, sequence parameters, events, English text, states or similar terms are printed with the first letter of each word in uppercase and the rest lower-case; e.g., In, Out, Request Status. Any lower- case uses of these words have the normal American-English meaning.

The American convention of numbering is used i.e., the thousands and higher multiples are separated by a comma and a period is used as the decimal point. This is equivalent to the ISO convention of a space and comma.

American:	0.6	ISO:	0,6
	1,000		1 000
	1,323,462.9		1 323 462,9

5. 5 1/4" 9.5mm Height Optical Drive PATA Form Factor

This section of the specification defines the configuration characteristics associated with 5 1/4" 9.5mm height optical drives. Table 5-1 lists the dimensions associated with Figure 5-1, which is a detail of the form factor. Tolerances are shown in the table.

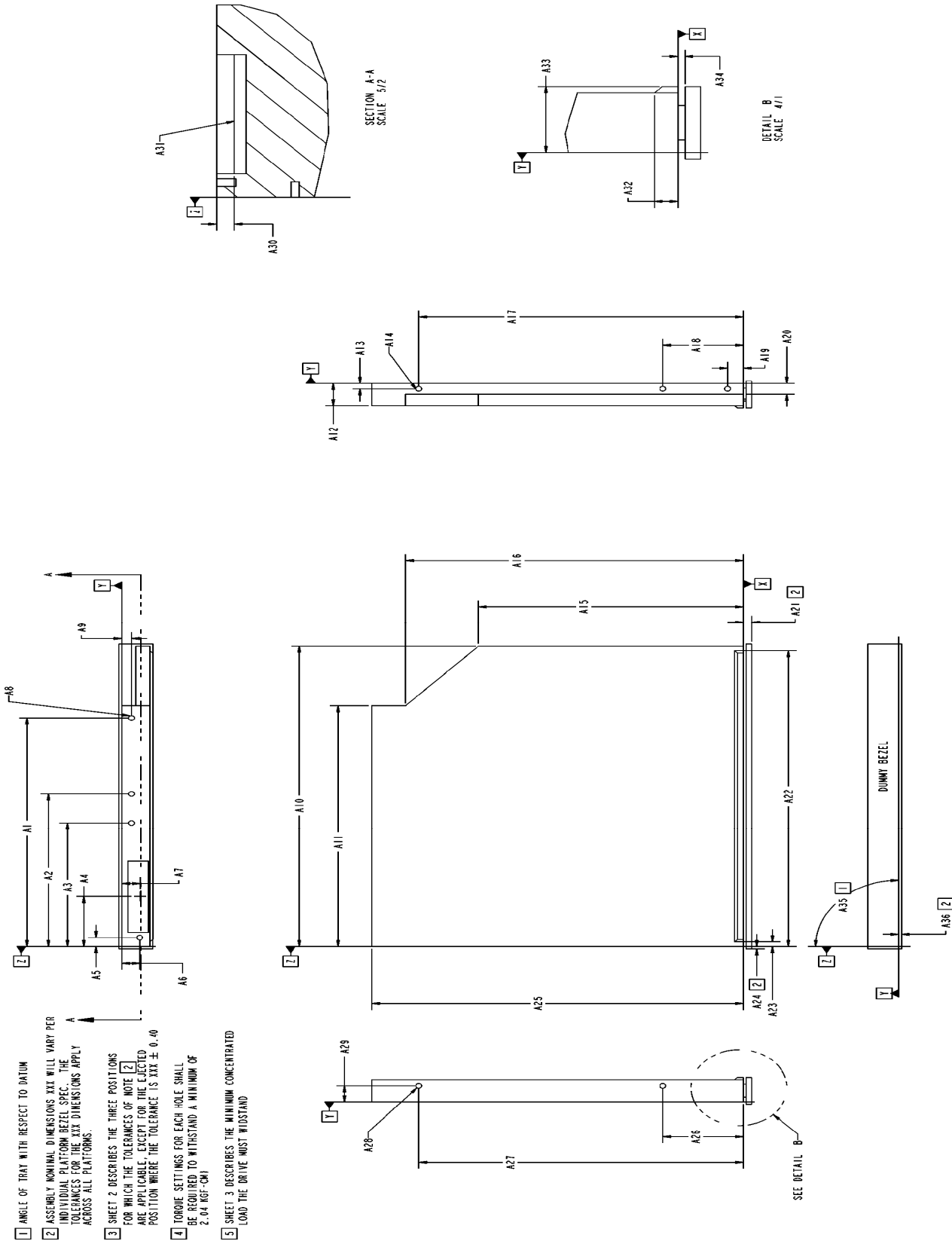

Figure 5-1: Sheet 1 - 5 1/4" 9.5mm Height Optical Drive Parallel ATA Form Factor

The three views below describe the positions where the tolerance(s) of the dimension(s) from the table are applicable, except for the ejected position where the tolerance for the dimension changes to  $\pm 0.40\text{mm}$ .

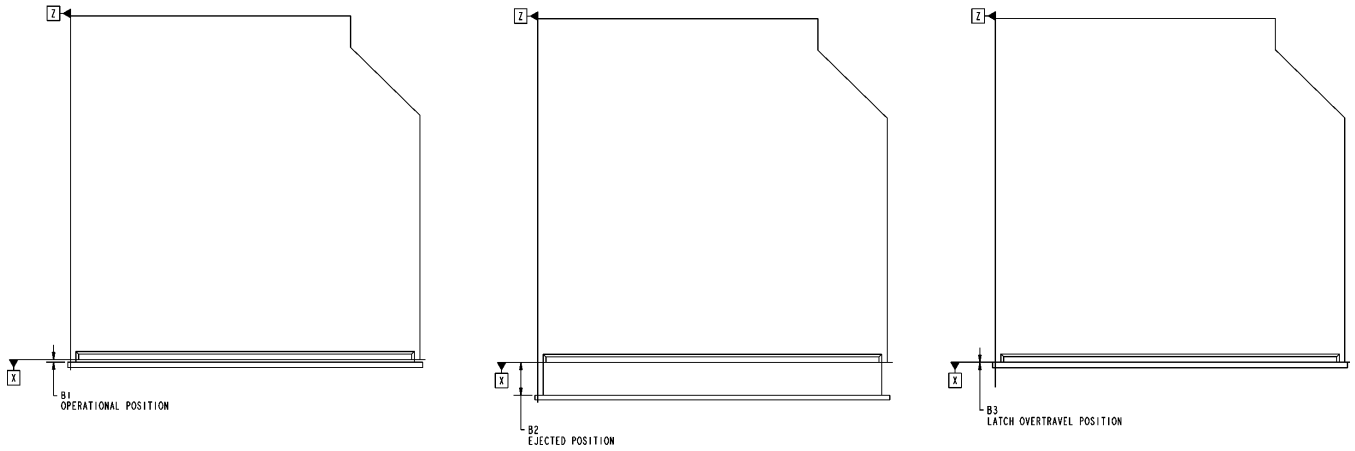
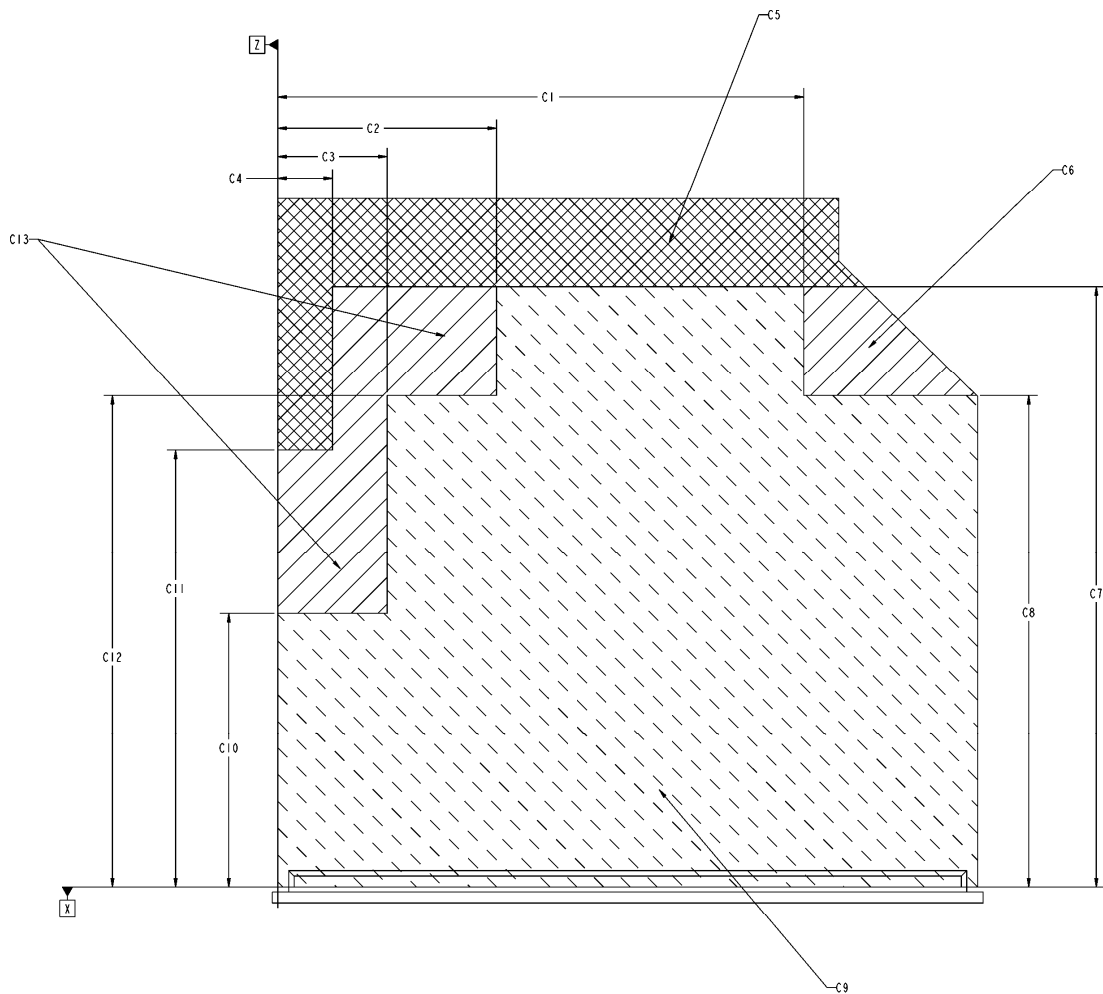

Figure 5-2: Sheet 2 - Tray Positions



Minimum concentrated loads the drive must be able to withstand. See table for values.

Figure 5-3: Sheet 3 - Loading Specifications

Table 5-1: Required Dimensions for 5 1/4" 9.5mm Height Optical Drive PATA Form Factor

Designator	Dimension (mm)	Tolerance (mm)	Notes
A1	97.40	±.20	
A2	65.10	±.20	
A3	52.60	±.20	
A4	21.25	±.30	Distance to centerline of ATA connector
A5	3.80	±.20	
A6	6.00	±.30	Distance to centerline of ATA connector
A7	6.15	±.30	Connector center
A8	4X M2	Depth 1.5 Min	Min screw engagement: 1.2, Max Screw engagement 1.5, Torque settings for each hole shall be required to withstand a minimum of 2.04 KGF-CM
A9	3X 3.20	±.20	
A10	128.00	±.20	
A11	102.60	±.20	
A12	9.50	+.50/-.20	Max Drive thickness (excludes label thickness. If an additional thickness is required, for example for a label, it must be no greater than .35mm).
A13	3X 2.30	±.20	
A14	3X M2	Depth 1.5 Min	Min screw engagement: 1.2, Max screw engagement 1.5, Torque settings for each hole shall be required to withstand a minimum of 2.04 KGF-CM
A15	89.85	±.85	
A16	114.65	±.75	
A17	110.10	±.20	
A18	27.30	±.20	
A19	5.30	±.20	
A20	4.60	±.20	
A21	XXX	±.30	Assembly nominal dimensions XXX may vary. The tolerances for the XXX dimensions apply across all platforms.
A22	126.00	Max	
A23	2.00	Min	
A24	XXX	±.30	Assembly nominal dimensions XXX may vary. See Clause 7. The tolerances for the XXX dimensions apply across all platforms.
A25	126.10	±.20	
A26	27.30	±.20	
A27	110.10	±.20	
A28	2X M2	Depth 1.5 Min	Min screw engagement: 1.2, Max screw engagement 1.5, Torque settings for each hole shall be required to withstand a minimum of 2.04 KGF-CM
A29	2X 6.80	±.20	
A30	3.60	±.30	
A31			Center of connector boss, JAE KX15-50KLD or equivalent
A32	3.00	Max	
A33	10.50	Max	Protrusion
A34	0.90	±.20	
A35	90.0 degrees	±3.0 degrees	Angle of tray with respect to Datums A and B
A36	XXX	±.30	Assembly nominal dimensions XXX may vary. The tolerances for the XXX dimensions apply across all platforms.
B1	0.90		Assembly nominal dimensions XXX may vary. The tolerances for the XXX dimensions apply across all platforms. Sheet 5-2 describes the three positions for which the tolerances are applicable, except for the ejected position where the tolerance is XXX ± 0.40.
B2	12.00		
B3	0.00		
C1	96.20		
C2	40.00		
C3	20.00		
C4	10.00		
C5	Less than 1	Newtons	
C6	Less than 0.5	Newtons	
C7	110.00		
C8	90.00		
C9	0.00	Newtons	
C10	50.00		
C11	80.00		
C12	90.00		
C13	Less than 0.5	Newtons	

6. 5 1/4" 12.7mm Height Optical Drive PATA Form Factor

This section of the specification defines the configuration characteristics associated with 5 1/4" 12.7mm height optical drives. Table 6-1 lists the dimensions associated with Figures 6-1, 6-2, and 6-3. The tolerances are listed in the table.

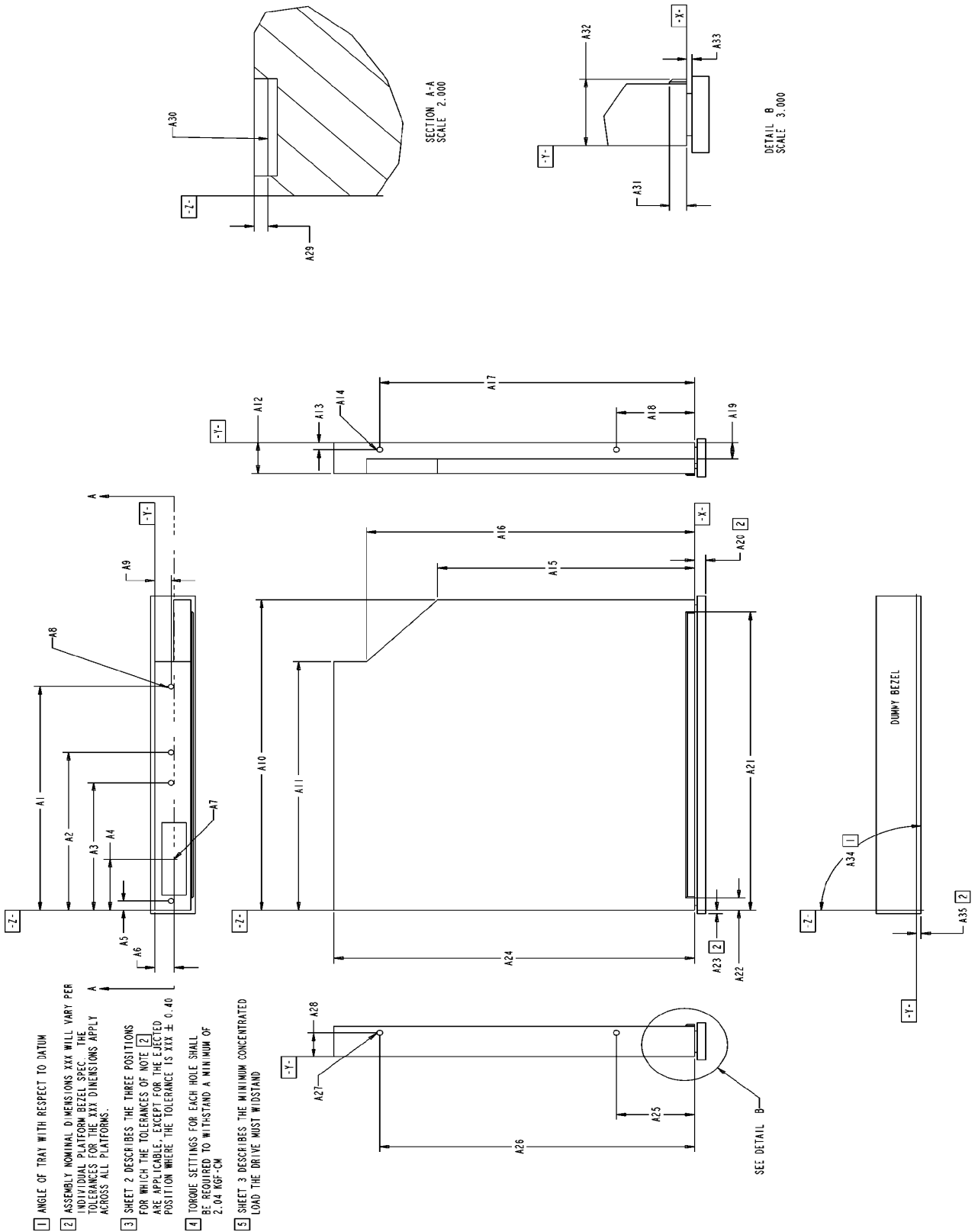

Figure 6-1: Sheet 1 - 5 1/4" 12.7mm Height Optical Disk Drive Parallel ATA Form Factor

The three views below describe the positions where the tolerance(s) of the dimension(s) from the table are applicable, except for the ejected position where the tolerance for the dimension changes to +/-0.40mm.

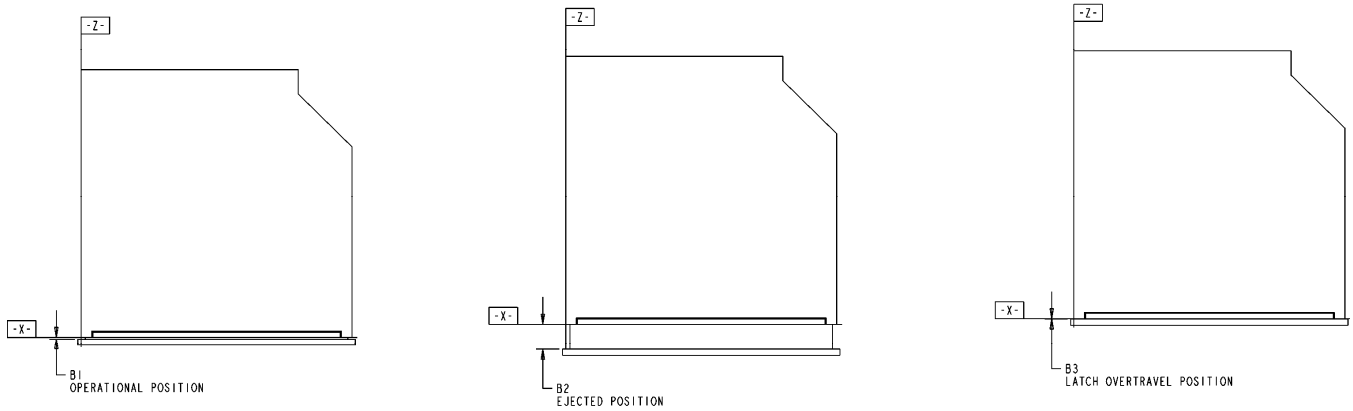
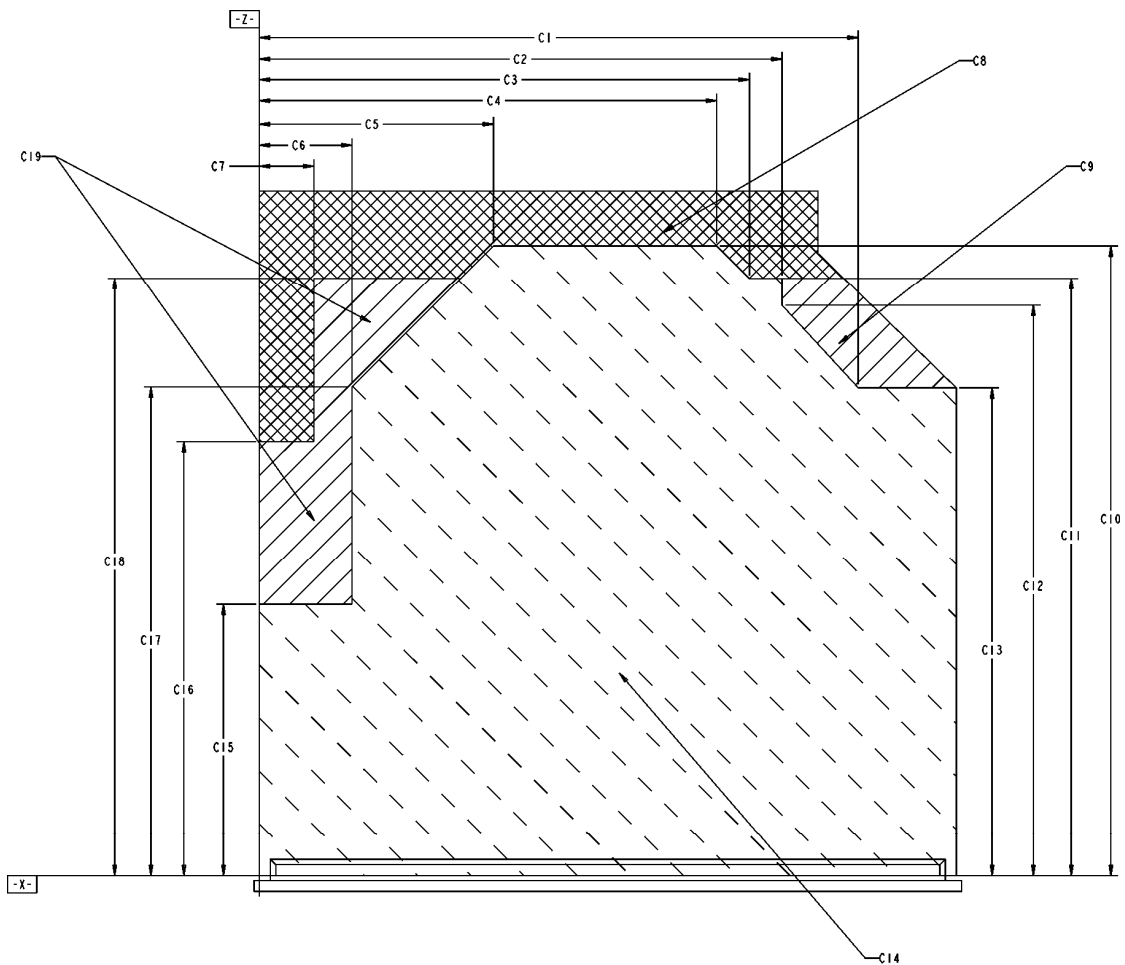

Figure 6-2: Sheet 2 - Tray Positions



Minimum concentrated loads the drive must be able to withstand. See table for values.

Figure 6-3: Sheet 3 - Loading Specifications

Table 6-1: Required Dimensions for 5 1/4" 12.7mm Height Optical Drive PATA Form Factor

Designator	Dimension (mm)	Tolerance (mm)	Notes
A1	92.40	±.20	
A2	65.10	±.20	
A3	52.60	±.20	
A4	21.25	±.20	Distance to centerline of ATA connector
A5	3.80	±.20	
A6	6.80	±.20	Distance to centerline of ATA connector
A7			Connector Center
A8	4X M2	Depth 1.5 Min	Min screw engagement: 1.2, Max screw engagement 1.5, Torque settings for each hole shall be required to withstand a minimum of 2.04 KGF-CM
A9	4X 5.70	±.20	
A10	128.00	±.20	
A11	102.60	±.20	
A12	12.70	±.20	Max Drive thickness (excludes label thickness. If an additional thickness is required, for example for a label, it must be no greater than .35mm).
A13	3.00	±.20	
A14	2X M2	Depth 1.5 Min	Min screw engagement: 1.2, Max screw engagement 1.5, Torque settings for each hole shall be required to withstand a minimum of 2.04 KGF-CM
A15	89.85	±.85	
A16	114.65	±.75	
A17	110.10	±.20	
A18	27.30	±.20	
A19	6.70	±.40	
A20	XXX	±.30	Assembly nominal dimensions XXX may vary per individual Optional Bezel Spec. See Clause 7. The tolerance for the XXX dimensions apply across all platforms.
A21	123.00	Max	
A22	5.00	Min	
A23	XXX	±.30	Assembly nominal dimensions XXX may vary per individual Optional Bezel Spec. See Clause 7. The tolerance for the XXX dimensions apply across all platforms.
A24	126.10	±.20	
A25	27.30	±.20	
A26	110.10	±.20	
A27	2X M2	Depth 1.5 Min	Min screw engagement: 1.2, Max screw engagement 1.5, Torque settings for each hole shall be required to withstand a minimum of 2.04 KGF-CM
A28	10.00	±.20	
A29	3.6	±.20	
A30			Center of connector boss, JAE KX-50KLD or equivalent
A31	3.00	Max	
A32	13.60	Max	Protrusion
A33	0.90	±.20	
A34	90.0 degrees	±3.0 degrees	Angle with respect to Datums A and B.
A35	XXX	±.30	Assembly nominal dimensions XXX may vary per individual Optional Bezel Spec, See Clause 7. The tolerance for the XXX dimensions apply across all platforms.
B1	0.90		Assembly nominal dimensions XXX may vary per individual Optional Bezel Spec, see Clause 7. The tolerances for the XXX dimensions apply across all platforms. Sheet 5-2 describes the three positions for which the tolerances are applicable, except for the ejected position where the tolerance is XXX ± 0.40.
B2	12.00		
B3	0.00		
C1	110.00		
C2	96.00		
C3	90.00		
C4	84.00		
C5	43.00		
C6	17.00		
C7	10.00		

C8	Less than 2	Newtons	
C9	Less than 1	Newtons	
C10	116.00		
C11	110.00		
C12	105.00		
C13	90.00		
C14	0.00		
C15	50.00		
C16	80.00		
C17	90.00		
C18	110.00		
C19	Less than 1	Newtons	



## 7. Optional 12.7mm Height Optical Bezel Attachment Specification

### 7.1 Content

The content of Clause 7 was contributed by Daniel Whittaker and Dirk Erickson of Dell Computer Corporation, with assistance from contributing companies of HLDS, Panasonic, TEAC, and TSST.

### 7.2. Purpose/Objective

This clause defines the interface between a 12.7mm Height optical bezel and 12.7mm Height optical drives.

### 7.3. Bezel Side Specifications

#### 7.3.1 Bezel Alignment Pin

##### 7.3.1.1 Alignment Pin Dimensions

Figure 7.1 shows the dimensions for the Alignment pin on the back of the bezel.

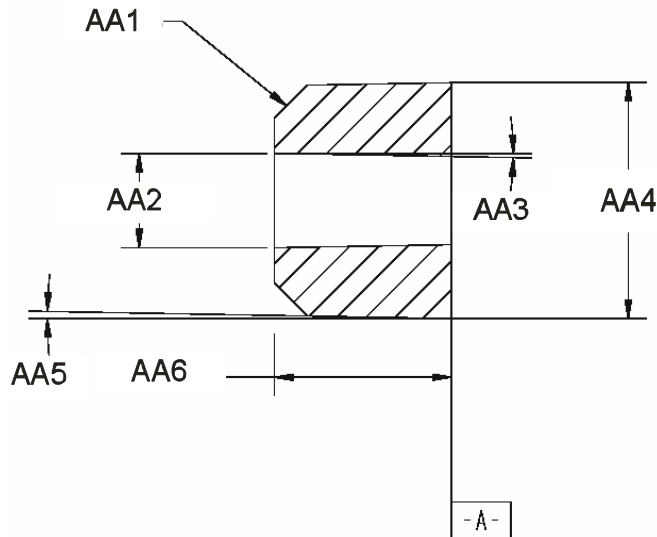

Figure 7.1

Designator	Dimension (mm)	Tolerance (mm)	Notes
AA1	C 0.3		
AA2	.80	±.10	∅
AA3	1.0°		Degrees, draft
AA4	2.00	+ .00 / - .05	∅
AA5	1.0°		Degrees, draft
AA6	1.50	±.10	

7.3.1.2 Location of Alignment Pin

The location of the bezel alignment pin is described in Figure 7.2.

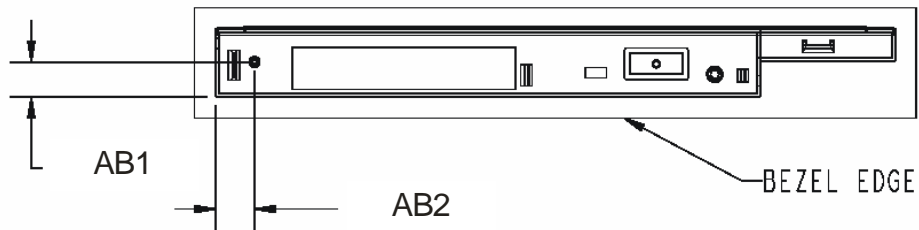

Figure 7.2

Designator	Dimension (mm)	Tolerance (mm)	Notes
AB1	6.50	±.05	
AB2	7.30	±.05	

### 7.3.2 Bezel Snap Number 1 Definition

#### 7.3.2.1 Snap Dimensions

Snap number one shall be a cantilever snap connector. The dimensions are as follows in Figure 7.3. Datum A represents the back surface of the bezel. This surface makes contact with the surface of the tray. Dimension X is a variable dimension. It may scale from 0.0mm in the case where the bezel is not cored, to value X where the bezel is cored.

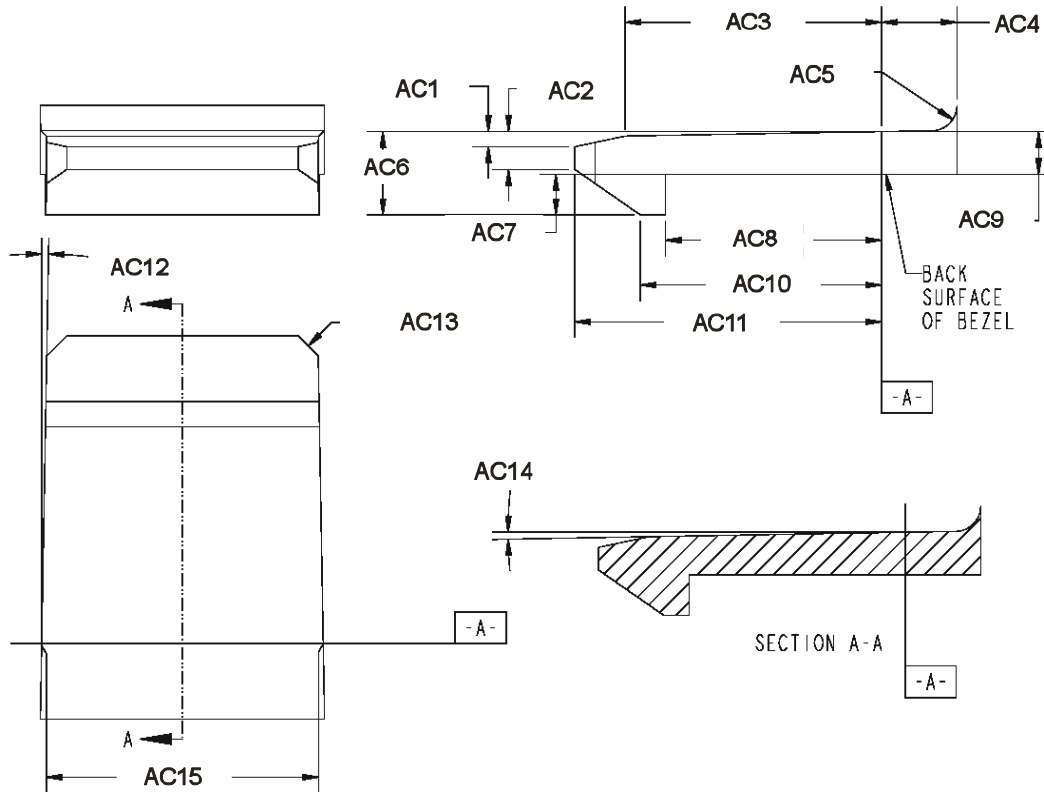

Figure 7.3

Designator	Dimension (mm)	Tolerance (mm)	Notes
AC1	.30	±.10	
AC2	.75	±.10	
AC3	5.10	±.10	
AC4	X		See text
AC5	.5	±.10	Radius
AC6	(1.65)		Reference
AC7	.80	±.05	
AC8	4.30	+.10/-.00	
AC9	.85	±.10	
AC10	4.80	±.10	
AC11	6.10	±.10	
AC12	2 - 1.0°		Degrees, draft
AC13	2 - 45° x .500		Degrees
AC14	1.0°		Degrees, draft
AC15	5.60	±.10	

### 7.3.2.2 Location of Snap

The position and location of the snap are described in Figure 7.4.

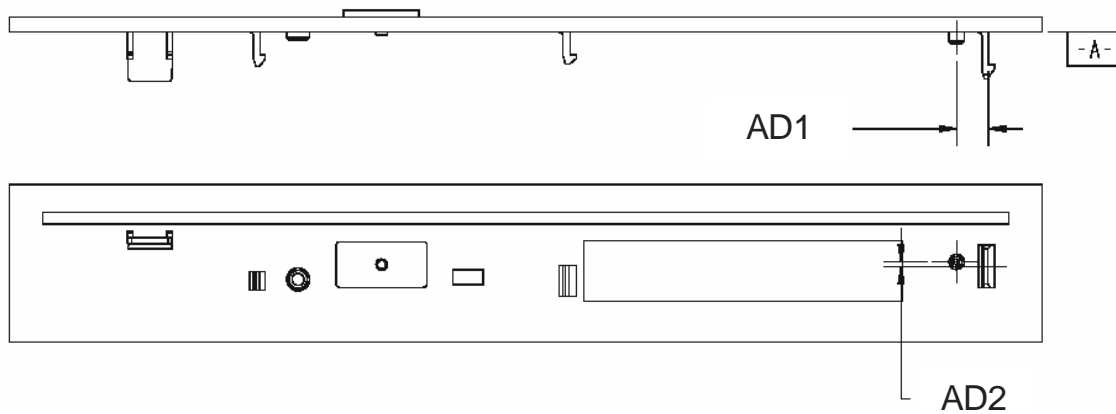

Figure 7.4

Designator	Dimension (mm)	Tolerance (mm)	Notes
AD1	4.20	+ .00 / - .10	
AD2	.60	± .10	

### 7.3.3 Bezel Snap Number 2 Definition

#### 7.3.3.1 Snap Dimensions

Snap number two shall be a cantilever snap connector. The dimensions are specified in Figure 7.5. Datum A represents the back surface of the bezel. This surface makes contact with the surface of the tray. Dimension X is a variable dimension. It may scale from 0.0mm in the case where the bezel is not cored, to value X where the bezel is cored.

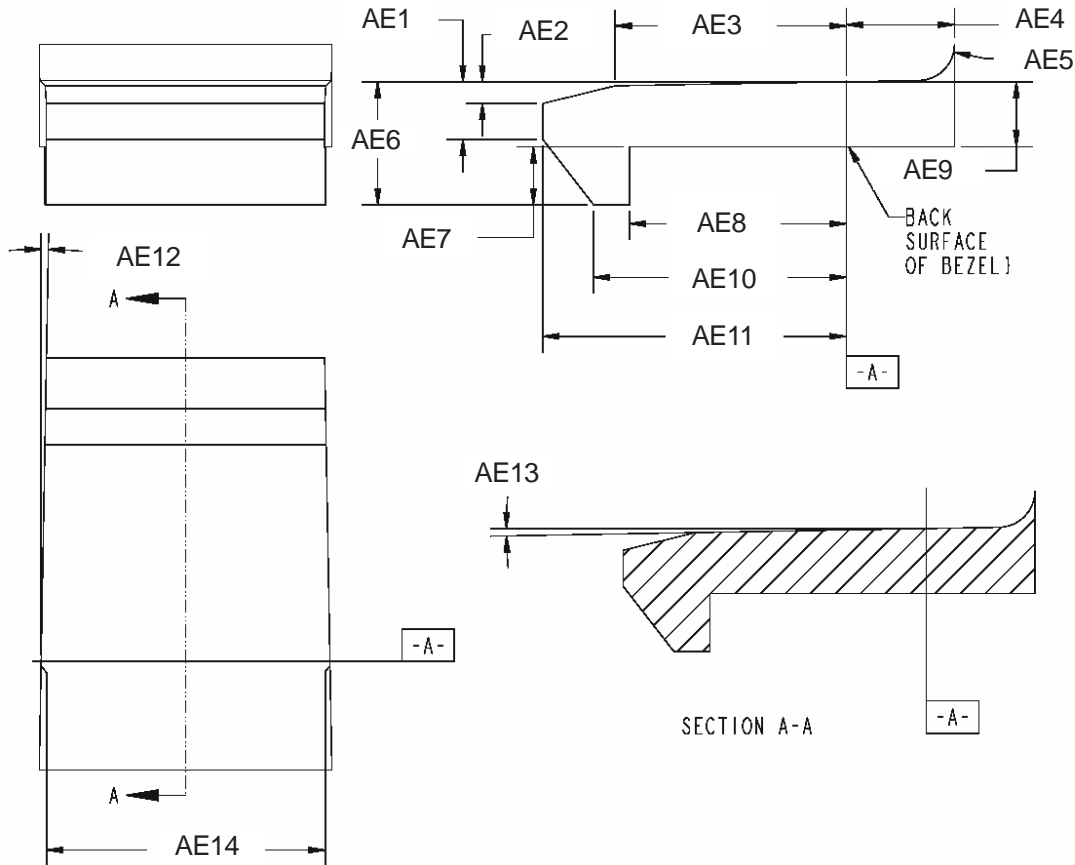

Figure 7.5

Designator	Dimension (mm)	Tolerance (mm)	Notes
AE1	.80	±.10	
AE2	.30	±.10	
AE3	3.20	±.10	
AE4	X		See Text
AE5	.50	±.10	Radius
AE6	(1.70)		Reference
AE7	.80	±.05	
AE8	3.00	+ .10 / - .00	
AE9	.90	±.10	
AE10	3.50	±.10	
AE11	4.20	±.10	
AE12	2 - 1.0°		Degrees, draft
AE13	1.0°		Degrees, draft
AE14	4.00	±.10	

### 7.3.3.2 Location of Snap

The position and location of the snap are specified in Figure 7.6.

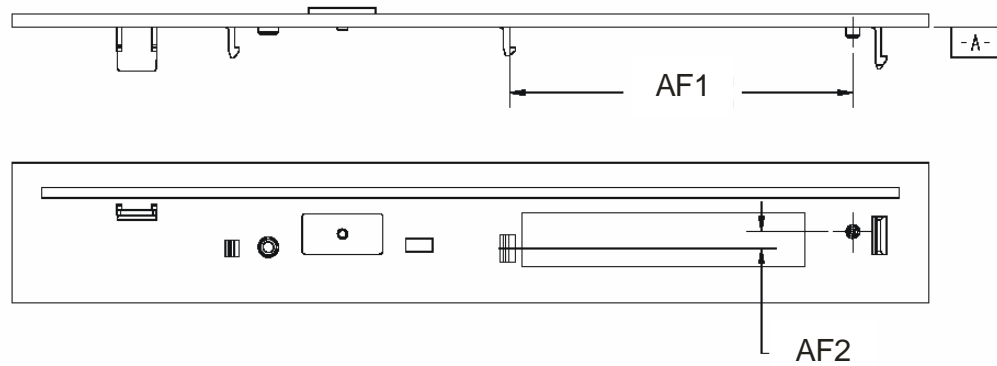

Figure 7.6

Designator	Dimension (mm)	Tolerance (mm)	Notes
AF1	50.90	+ .10 / - .00	
AF2	2.50	± .10	

### 7.3.4 Bezel Snap Number 3 Definition

#### 7.3.4.1 Snap Dimensions

Snap number three shall be a cantilever snap connector. The dimensions are specified in Figure 7.7. Datum A represents the back surface of the bezel. This surface makes contact with the surface of the tray. Dimension X is a variable dimension. It may scale from 0.0mm in the case where the bezel is not cored, to value X where the bezel is cored.

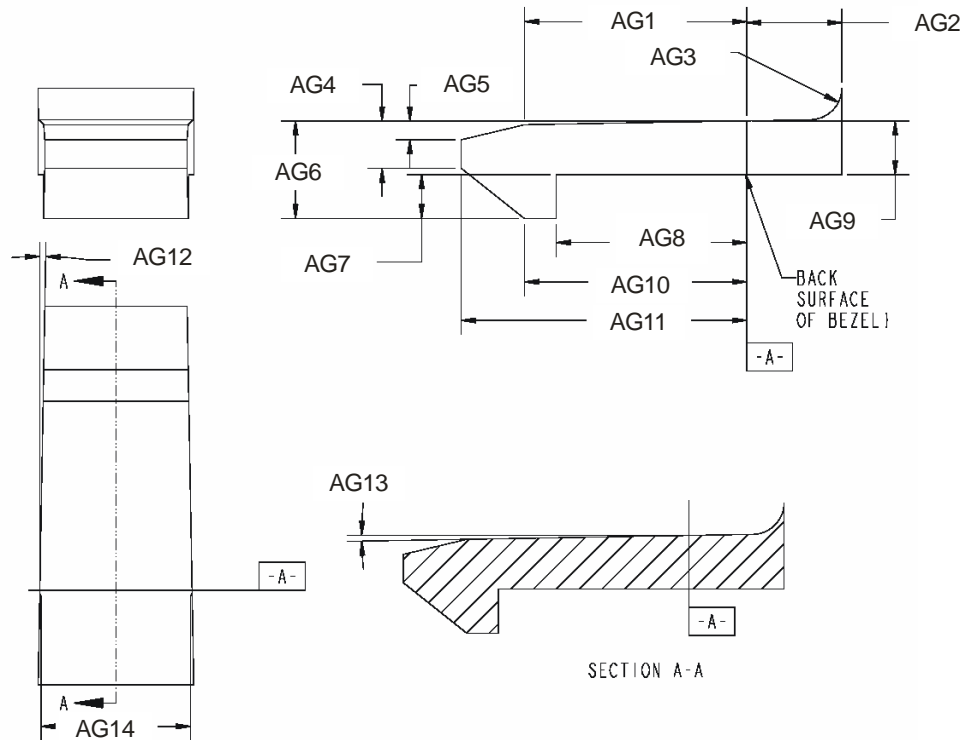

Figure 7.7

Designator	Dimension (mm)	Tolerance (mm)	Notes
AG1	3.50	±.10	
AG2	X		See text
AG3	.50	±.10	Radius
AG4	.75	±.10	
AG5	.30	±.10	
AG6	(1.55)		Reference
AG7	.70	±.05	
AG8	3.00	+.10/-.00	
AG9	.85	±.10	
AG10	3.50	±.10	
AG11	4.50	±.10	
AG12	2 - 1.0°		Degrees, draft
AG13	1.0°		Degrees, draft
AG14	2.4	±.10	

**7.3.4.2 Location of Snap**

The position and location of the snap are specified in Figure 7.8.

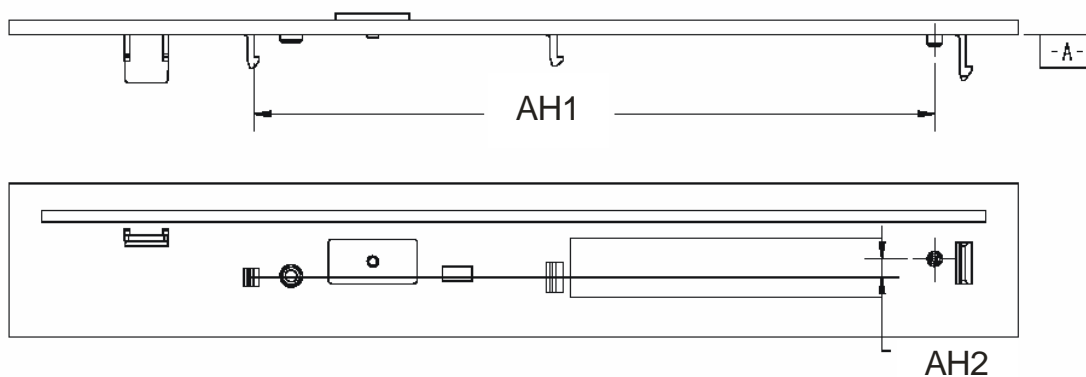

Figure 7.8

Designator	Dimension (mm)	Tolerance (mm)	Notes
AH1	91.70	+ .10 / - .00	
AH2	2.50	± .10	



7.3.5 Bezel Snap Number 4 Definition

7.3.5.1 Snap Dimensions

Snap number four shall be a cantilever snap connector. The dimensions are specified in Figure 7.9.

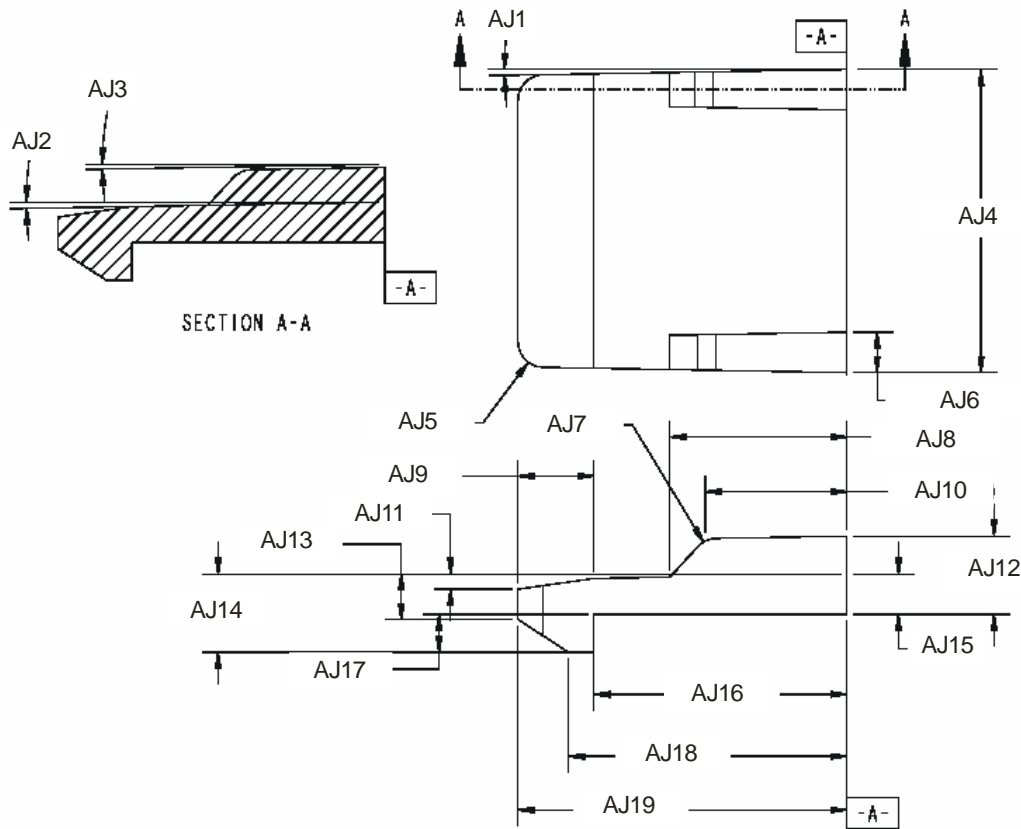

Figure 7.9

Designator	Dimension (mm)	Tolerance (mm)	Notes
AJ1	1.0°		Degrees, draft
AJ2	1.0°		Degrees, draft
AJ3	1.0°		Degrees, draft
AJ4	6.00	±.10	
AJ5	2 - R.50		Radius
AJ6	2 - .80	±.10	
AJ7	2 - R.50		Radius
AJ8	3.50	±.10	
AJ9	1.50	±.10	
AJ10	2.80	±.10	
AJ11	.30	±.10	
AJ12	1.55	+.00/-.10	
AJ13	.90	±.10	
AJ14	1.55	±.10	
AJ15	(.80)		Reference
AJ16	5.00	+.10/-.00	
AJ17	.75	±.05	
AJ18	5.50	±.10	
AJ19	6.50	±.10	

**7.3.5.2 Location of Snap**

The position and location of the snap are specified in Figure 7.10.

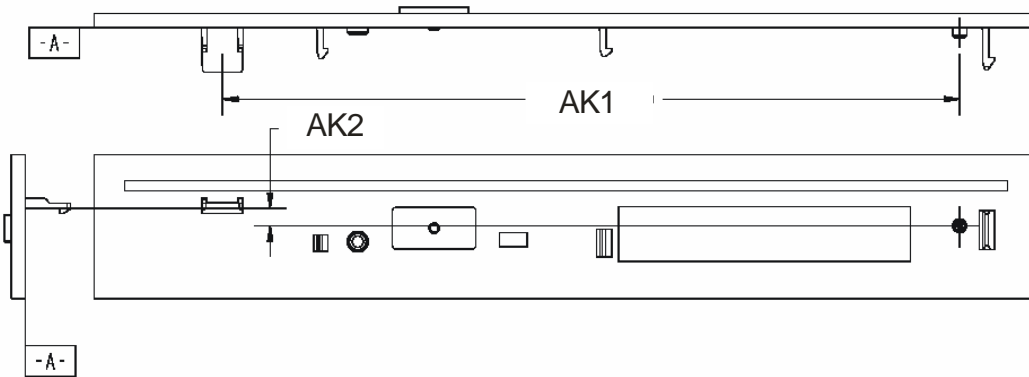

Figure 7.10

Designator	Dimension (mm)	Tolerance (mm)	Notes
AK1	106.20	±.10	
AK2	2.50	±.10	

**7.3.6 Datum A Definition**

The plane, Datum A, may not have any feature break its plane from the bezel except for the features defined in this specification that are attached to the bezel.

**7.3.6.1 Implementers Note**

Flex cables are used to attach the LED and eject buttons. Figure 7.11 shows dimension AL2. Dimension AL2 should be a minimum of 0.7mm for a compliant bezel so that the button may not cross Datum A when pressed. If a bezel supplier cannot meet dimension AL2 specification due to a thin bezel design (causes cosmetic issues, etc.), a bezel designed specifically to meet the drive requirements may be needed.

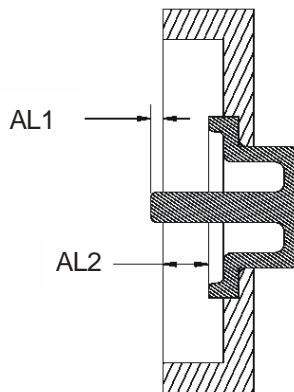

Figure 7.11

Designator	Dimension (mm)	Tolerance (mm)	Notes
AL1	.40	+.00/-.10	
AL2	.7	Min	

### 7.3.7 Switch and LED

#### 7.3.7.1 Location of Switch and LED

The location of the switch and LED are specified in Figure 7.12. The crosshatched circle represents the switch, and the crosshatched rectangle represents the LED. The shapes are not intended to define the physical appearance of the switch and/or LED but are placeholders for reference.

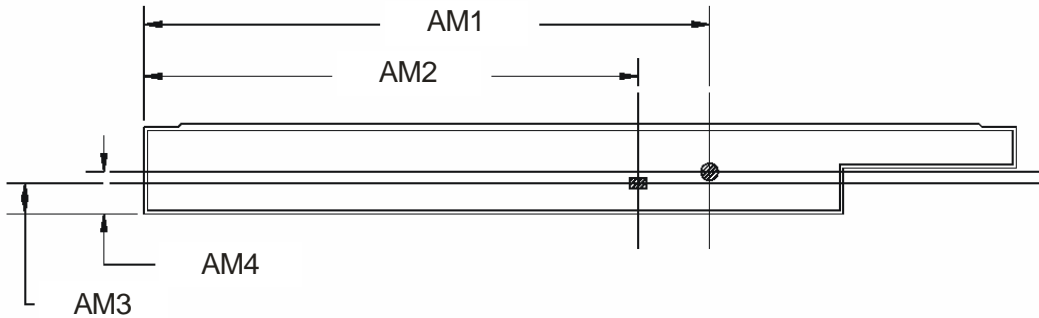

Figure 7.12

Designator	Dimension (mm)	Tolerance (mm)	Notes
AM1	83.00	±.10	
AM2	72.50	±.15	
AM3	4.50	±.10	
AM4	6.15	±.10	

**7.3.7.2 Button Position/Activation Points**

Figure 7.12 defines the position of the button in the X and Y axis. For the Z-axis the button shall be sub-flush of Datum B by 0.6 +/- 0.15mm. The button shall activate when depressed within a range of 0.05mm to 0.35mm. The button activation pin's length is defined as 0.4 +0.0 /-0.1mm from the back plane of the bezel in Detail A in Figure 7.13.

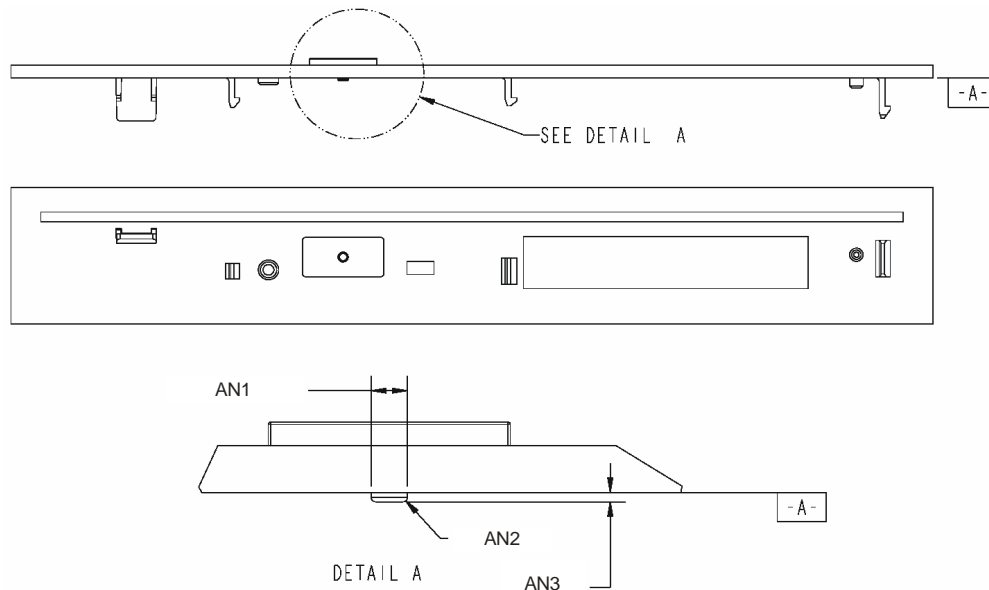

Figure 7.13

Designator	Dimension (mm)	Tolerance (mm)	Notes
AN1	0.8 - 1.6		∅
AN2	.20	Min	Radius
AN3	.40	+0.00/-0.10	

**7.3.7.3 LED Position**

Figure 7.12 defines the position of the LED in the X and Y axis. For the Z-axis the LED may only protrude a maximum of 0.2mm from the front plane of the tray, Datum B. The bezel shall allow for a LED that protrudes this far.

**7.3.8 Emergency Eject**

**7.3.8.1 Emergency Eject Hole Location**

The location of the emergency eject hole is described in Figure 7.14.

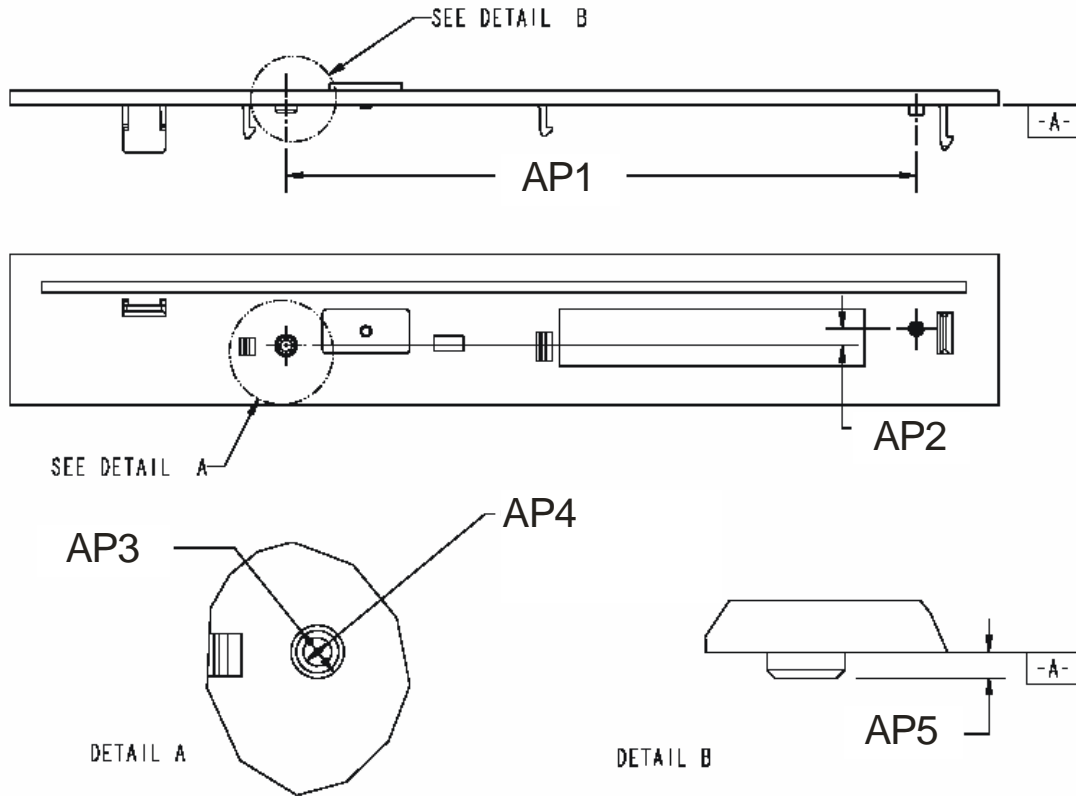

Figure 7.14

Designator	Dimension (mm)	Tolerance (mm)	Notes
AP1	86.70	±.10	
AP2	2.30	±.10	
AP3	3.00	±.10	∅
AP4	1.60	±.10	∅, Measured at the front of the bezel 1° draft
AP5	1.00	±.10	

**7.3.8.2 Emergency Eject Tube**

The emergency eject tube is defined as a cylindrical protrusion behind the emergency eject hole in the bezel to guide the emergency eject tool to the emergency eject mechanism. This tube's inside diameter is defined to be as large as the emergency eject hole (1.60 +/- 0.1mm). The tube's external diameter shall be 3.0 +/- 0.1 as seen in Detail A of Figure 7.14. The Distance the tube extends from the back of the bezel shall be 1.0 +/- 0.1mm from the back plane of the bezel as seen in Detail B in Figure 7.14.

### 7.3.9 Clearance for Pickup Unit Module (PUM)

#### 7.3.9.1 Location of Recessed Area

This is the area in the bezel where there is a defined recess for the PUM. See Figure 7.15.

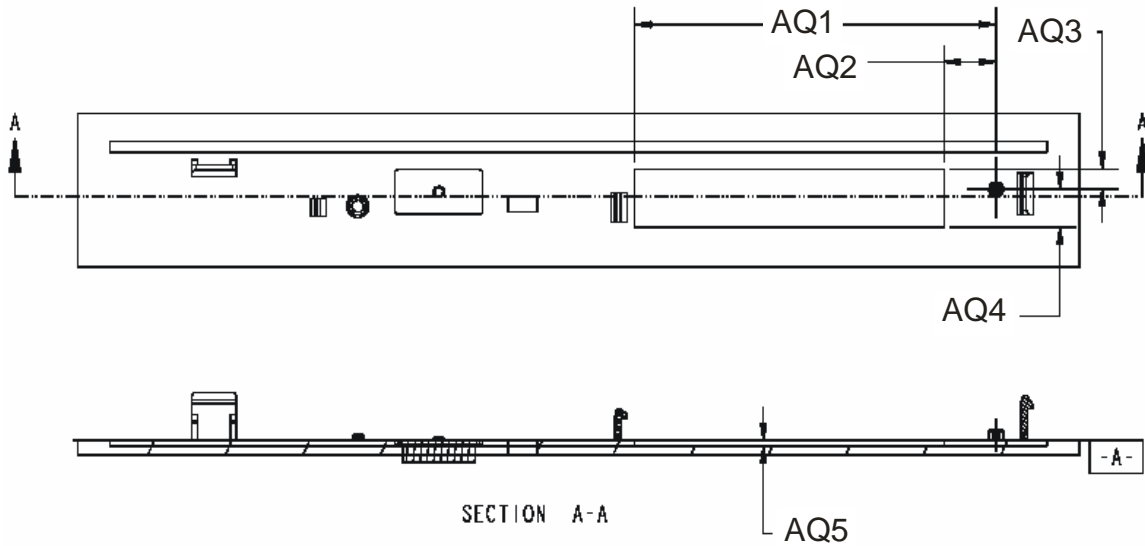

Figure 7.15

Designator	Dimension (mm)	Tolerance (mm)	Notes
AQ1	49.10	Min	
AQ2	7.10	Max	
AQ3	2.75	Min	
AQ4	5.15	Min	
AQ5	.80	Min	

#### 7.3.10 Acoustic Noise Pad (Optional)

This is an optional feature that may be used in bezel construction to dampen the acoustical noise made by the drive. This is an optional feature, however all drives shall be able to function with this feature implemented.

##### 7.3.10.1 Acoustic Noise Pad Location

Figure 7.16 describes the placement of the acoustic noise pad. The pad is allowed to have a maximum 0.05mm interference with the chassis of the drive. The Depth of the channel shall be 0.75mm.

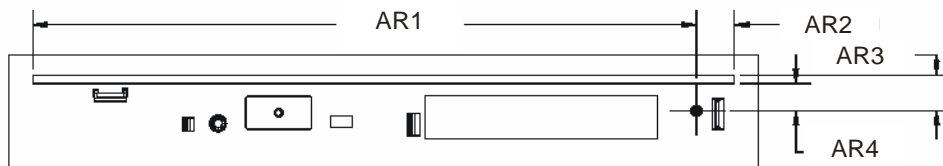

Figure 7.16

Designator	Dimension (mm)	Tolerance (mm)	Notes
AR1	120.30	±.10	
AR2	6.90	±.10	
AR3	6.50	Min	
AR4	5.00	+.20/- .00	

**7.3.10.2 Material requirements**

Suppliers shall use the below material requirement or equivalent.

Urethane Material  
 ZUREN-SDCK (Hardness: 9degree)  
 Maker: Bridgestone

**7.4. Tray Side Specifications**

**7.4.1 Grounding Touch point**

The entire case of the optical drive shall provide a path to ground.

**7.4.2 Tray Datum Definition**

Figure 7.17 defines Datum B which nothing except the LED from the tray side is allowed to cross. The LED is defined in section 7.3.7.3 and the PUM is defined in section 7.3.9.1.

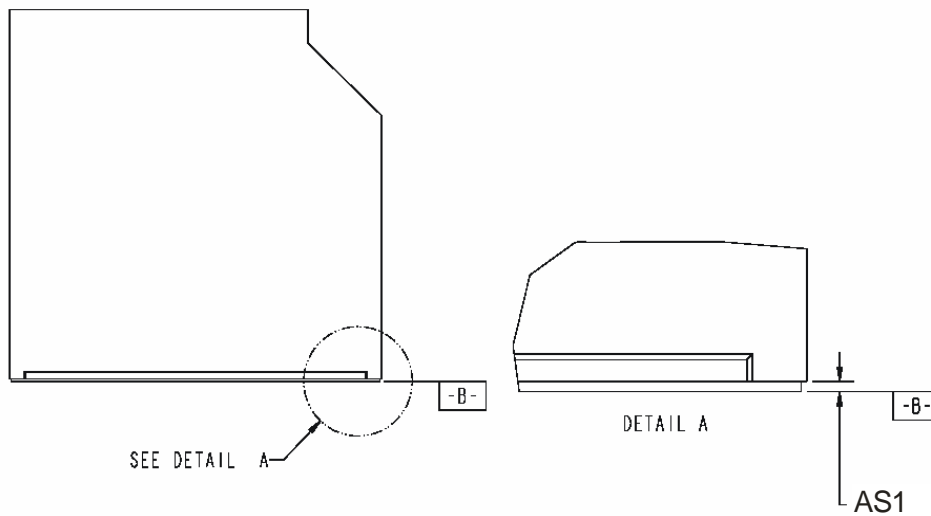

Figure 7.17

Designator	Dimension (mm)	Tolerance (mm)	Notes
AS1	.90	±.20	

**7.4.2.1 Tray Protrusion**

The tray shall protrude out of the chassis of the drive 0.9mm +/- 0.2mm.

### 7.4.3 Rib Touch Points

#### 7.4.3.1 Position of Touch Points

For cored bezels that need more stability, touch points are defined that guarantee areas on the tray that shall cause no issues when contacted by a rib or ribs on the bezel. Bezel rib contact is allowed in the areas without cross-hatching in Figure 7.18.

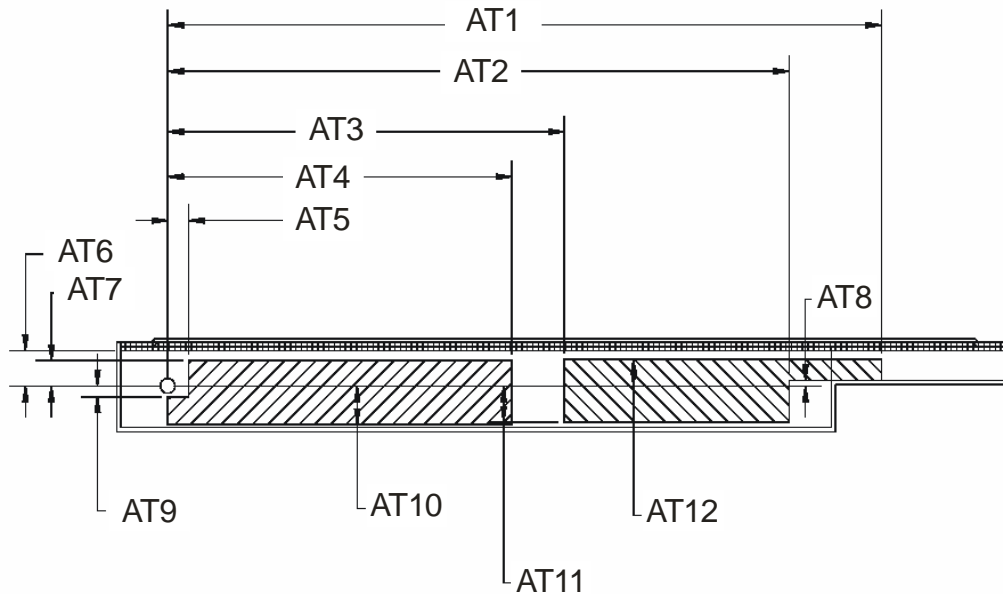

Figure 7.18

Designator	Dimension (mm)	Tolerance (mm)	Notes
AT1	101.90	Min	
AT2	88.70	Min	
AT3	56.60	Min	
AT4	49.10	Min	
AT5	3.00	Min	
AT6	5.00	Min	
AT7	3.60	Min	
AT8	.800	Max	
AT9	1.55	Max	
AT10	5.50	Min	
AT11	5.15	Min	
AT12	3.80	Min	

#### 7.4.4 Alignment Pin Hole

##### 7.4.4.1 Dimensions of Alignment Pin Hole

The dimension of the hole for the alignment pin is  $\text{Ø}2.05 +0.05/-0.0$ .

### 7.5. Implementers Guide

#### 7.5.1 Bezel Roll Off Prevention

The cross hatched areas below represent ribs in a cored bezel that preclude the bezel from being able to be removed easily by rolling downward with a force starting at the wing side of the tray. Figure 7.19 shows the areas where ribs shall be implemented in a cored bezel. The dimension "3.8 TO 3.1" means that the rib thickness may vary from 0.8mm thick to 1.5mm thick. However if a bezel relies on this feature for roll off protection, the feature shall work when at the minimum



material condition of 0.8mm thick. Detail A shows a dimension "X" which extends from the top of the snap all the way to the bottom of the bezel.

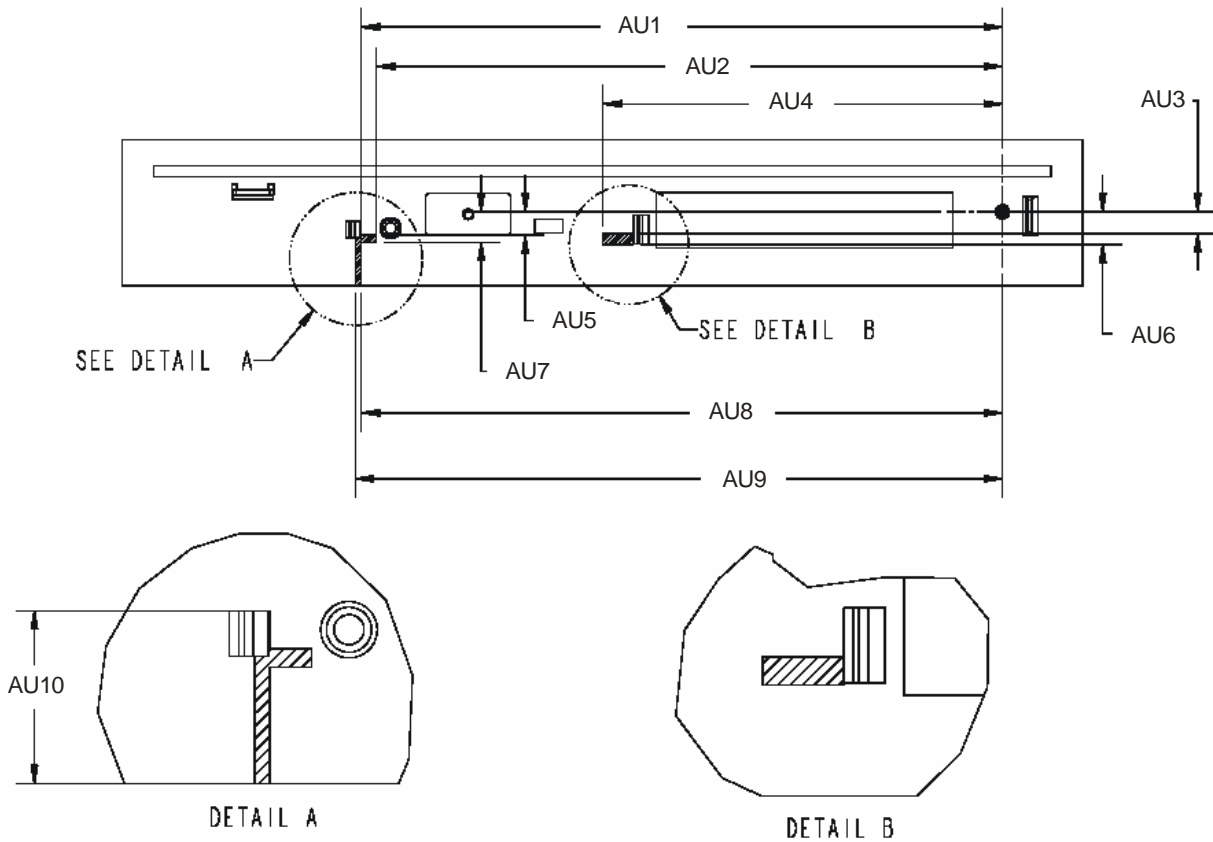

Figure 7.19 Areas where ribs shall be implemented in a cored bezel

Designator	Dimension (mm)	Tolerance (mm)	Notes
AU1	90.90		
AU2	88.70		
AU3	3.8 to 3.10		
AU4	56.60		
AU5	3.30		
AU6	4.60		
AU7	4.30		
AU8	90.90		
AU9	91.70		
AU10	X		

7.6 Clause 7 Revision History

Rev.	Revision Description	Date
1.0	Initial Release	8/13/04
1.01	Reformatted to conform to SFF requirements	12/05/04
1.1	Edited to incorporate SFF feedback	2/22/05

## 8. Optional 9.5mm Height Optical Bezel Attachment Specification

### 8.1 Content

The content of Clause 8 was contributed by Daniel Whittaker, Ravi Krishnan, and Godfrey Ting of Dell Computer Corporation, with assistance from contributing companies of HLDS, OptiArc, Panasonic, and TSST.

### 8.2. Purpose/Objective

This clause defines the interface between a 9.5mm Height optical bezel and 9.5mm Height optical drives.

### 8.3. Bezel Side Specifications

This section describes the features that are on the bezel only.

#### 8.3.1 Bezel Alignment Pin

##### 8.3.1.1 Alignment Pin Dimensions

Figure 8.1 shows the dimensions for the Alignment pin on the back of the bezel. Datum A represents the back surface of the bezel. This surface makes contact with the surface of the tray. Dimension X is a variable dimension. It may scale from 0.0mm in the case where the bezel is not cored, to value X where the bezel is cored. If the alignment pin causes sink marks on the front of the bezel the geometry of the pin can be changed, as long as the outer diameter stays the same. For instance pie shaped wedges can be removed. In the cases were BA2 is equal to zero, there will be a natural radius (Max 0.2mm) formed between the protruding features and the bezel.

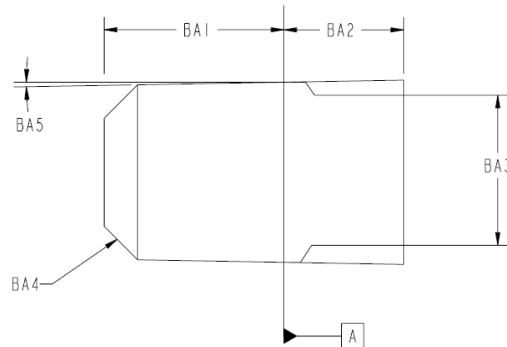

Figure 8.1

Designator	Dimension (mm)	Tolerance (mm)	Notes
BA1	1.5	±.10	
BA2	X		
BA3	1.5	+ .00 / - .05	∅
BA4	C 0.3		
BA5	1.0°		Degrees, draft

**8.3.1.2 Location of Alignment Pin**

The location of the bezel alignment pin on the bezel is described in Figure 8.2. X and Y represent the amount of bezel overhang you have from the edge of the drive by design. The Reference mark is also specified below. This mark is required on all bezels and is there to aid in the optical measurement of the bezel's features. This mark can be either convex or concave, however convex shapes must not exceed Datum A.

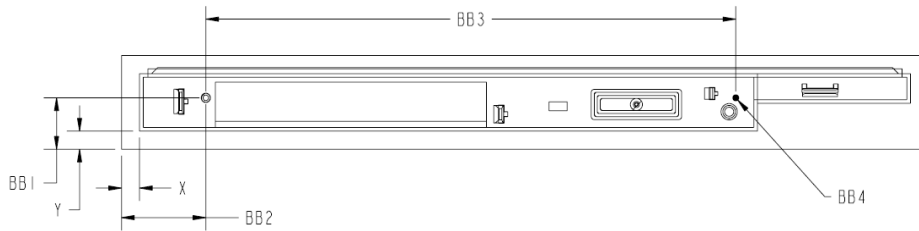

Figure 8.2

Designator	Dimension (mm)	Tolerance (mm)	Notes
BB1	Y+5.5	±.05	
BB2	X+11.0	±.05	
BB3	88	±.10	Reference Mark
BB4	1.00		Ø, Min; Reference Mark

### 8.3.2 Bezel Snap Number 1 Definition

#### 8.3.2.1 Snap Dimensions

Snap number one shall be a cantilever snap connector. The dimensions are as follows in Figure 8.3. Datum A represents the back surface of the bezel. This surface makes contact with the surface of the tray. Dimension X is a variable dimension. It may scale from 0.0mm in the case where the bezel is not cored, to value X where the bezel is cored.

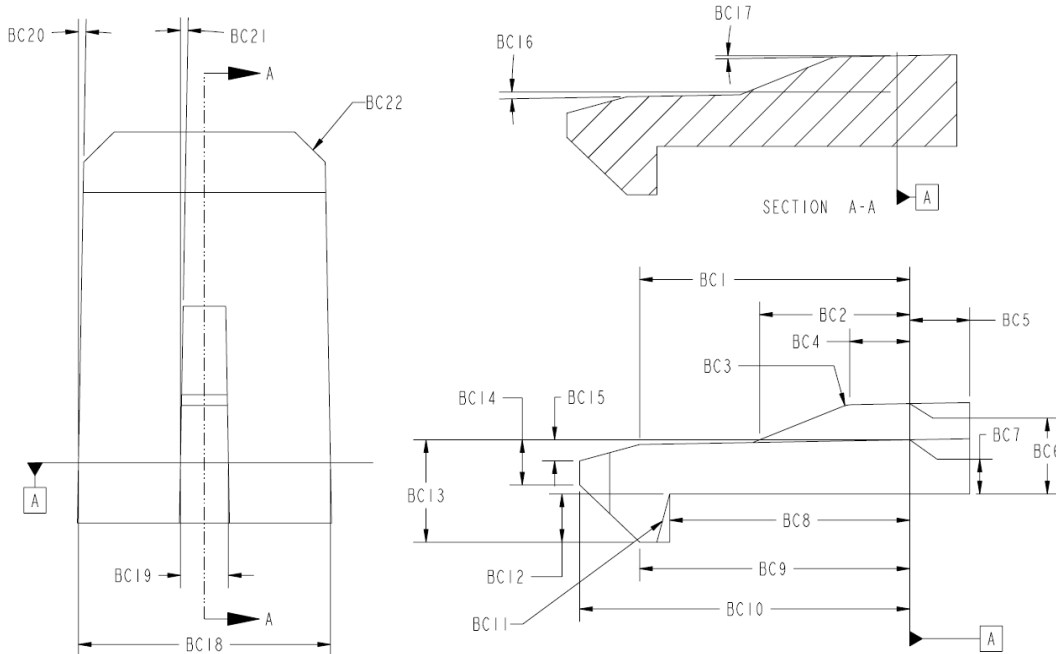

Figure 8.3

Designator	Dimension (mm)	Tolerance (mm)	Notes
BC1	4.5	±.10	
BC2	2.5	±.10	
BC3	0.5		Radius
BC4	1.0	±.10	
BC5	X		see text
BC6	1.5	+.00/- .10	
BC7	0.9	±.10	
BC8	4.00	+.10/- .00	
BC9	4.5	±.10	
BC10	5.5	±.10	
BC11	0.5°		Max Degrees, draft
BC12	0.8	±.05	
BC13	(1.7)		Reference
BC14	.75	±.10	
BC15	.35	±.10	
BC16	1.0°		Degrees, draft
BC17	1.0°		Degrees, draft
BC18	4.2	±.10	
BC19	.80	±.10	
BC20	1.0°		Degrees, draft
BC21	1.0°		Degrees, draft
BC22	2 - 45° x .500		Degrees

### 8.3.2.2 Location of Snap

The position and location of the snap are described in Figure 8.4.

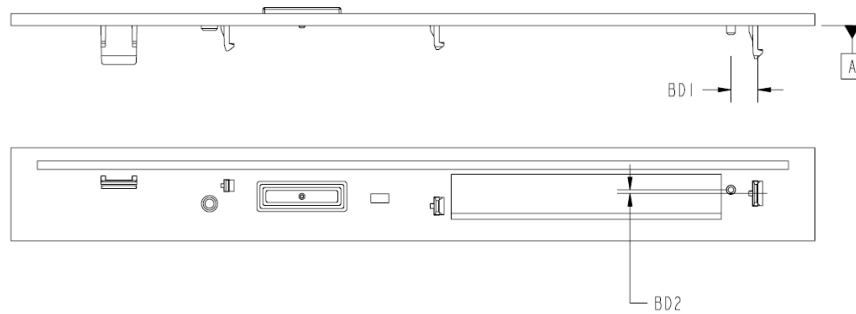

Figure 8.4

Designator	Dimension (mm)	Tolerance (mm)	Notes
BD1	4.50	+ .00 / - .10	
BD2	.60	± .10	

### 8.3.3 Bezel Snap Number 2 Definition

#### 8.3.3.1 Snap Dimensions

Snap number two shall be a cantilever snap connector. The dimensions are specified in Figure 8.5. Datum A represents the back surface of the bezel. This surface makes contact with the surface of the tray. Dimension X is a variable dimension. It may scale from 0.0mm in the case where the bezel is not cored, to value X where the bezel is cored.

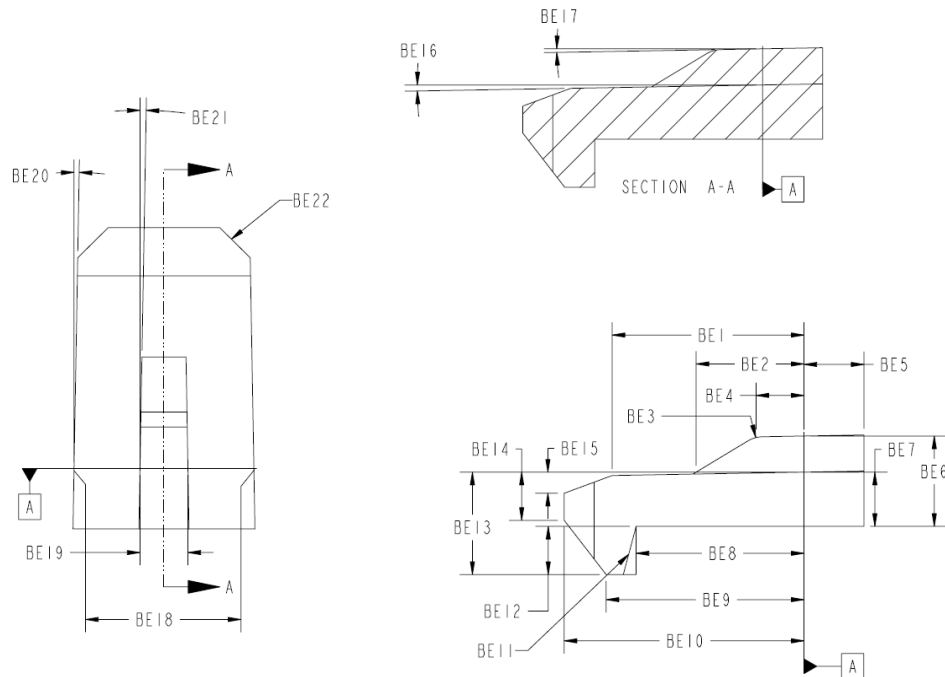

Figure 8.5

Designator	Dimension (mm)	Tolerance (mm)	Notes
BE1	3.20	±.10	
BE2	1.80	±.10	
BE3	R0.5		Radius
BE4	0.80	±.10	
BE5	X		See text
BE6	1.40	+0.00/-0.10	
BE7	0.90	±.10	
BE8	2.80	+0.10/-0.00	
BE9	3.30	±.10	
BE10	4.00	±.10	
BE11	0.5°		Max Degrees, draft
BE12	0.80	±.05	
BE13	(1.70)		Reference
BE14	0.80	±.10	
BE15	0.40	±.10	
BE16	1.0°		Degrees, draft
BE17	1.0°		Degrees, draft
BE18	3.00	±.10	
BE19	0.80	±.10	
BE20	1.0°		Degrees, draft
BE21	1.0°		Degrees, draft
BE22	2 - 45° x .500		Degrees

### 8.3.3.2 Location of Snap

The position and location of the snap are specified in Figure 8.6.

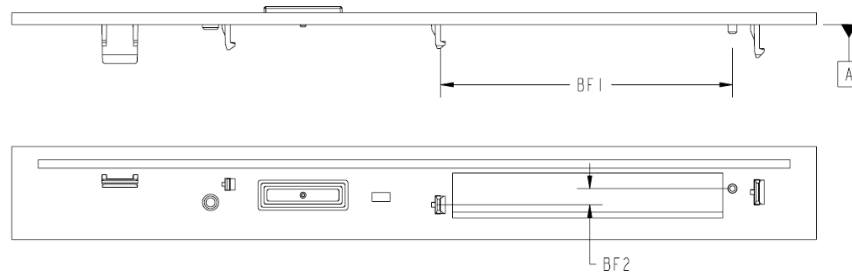

Figure 8.6

Designator	Dimension (mm)	Tolerance (mm)	Notes
BF1	48.60	+ .10 / - .00	
BF2	2.70	± .10	

### 8.3.4 Bezel Snap Number 3 Definition

#### 8.3.4.1 Snap Dimensions

Snap number three shall be a cantilever snap connector. The dimensions are specified in Figure 8.7. Datum A represents the back surface of the bezel. This surface makes contact with the surface of the tray. Dimension X is a variable dimension. It may scale from 0.0mm in the case where the bezel is not cored, to value X where the bezel is cored.

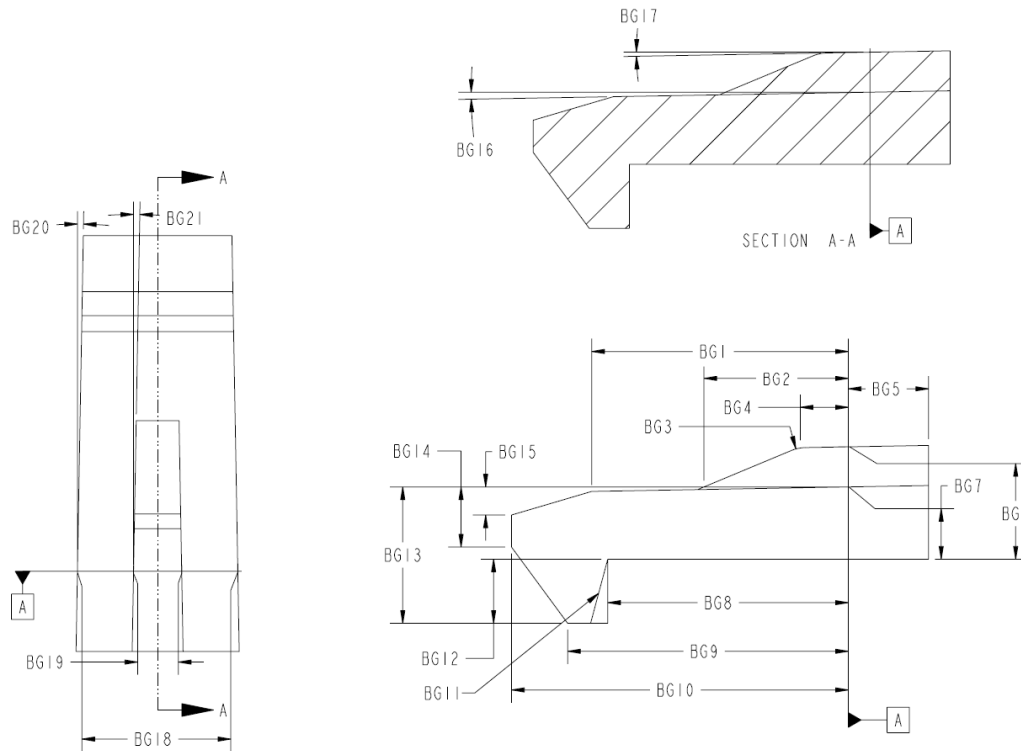

Figure 8.7

Designator	Dimension (mm)	Tolerance (mm)	Notes
BG1	3.2	±.10	
BG2	1.8	±.10	
BG3	0.5		Radius
BG4	.60	±.10	
BG5	X		See text
BG6	1.4	+.00/- .10	
BG7	.90	±.10	
BG8	3.00	+.10/- .00	
BG9	3.5	±.10	
BG10	4.2	±.10	
BG11	0.5°		Max Degrees, draft
BG12	.80	±.05	
BG13	(1.7)		Reference
BG14	.75	±.10	
BG15	.35	±.10	
BG16	1.0°		Degrees, draft
BG17	1.0°		Degrees, draft
BG18	2.00	±.10	
BG19	.60	±.10	
BG20	1.0°		Degrees, draft
BG21	1.0°		Degrees, draft



### 8.3.4.2 Location of Snap

The position and location of the snap are specified in Figure 8.8.

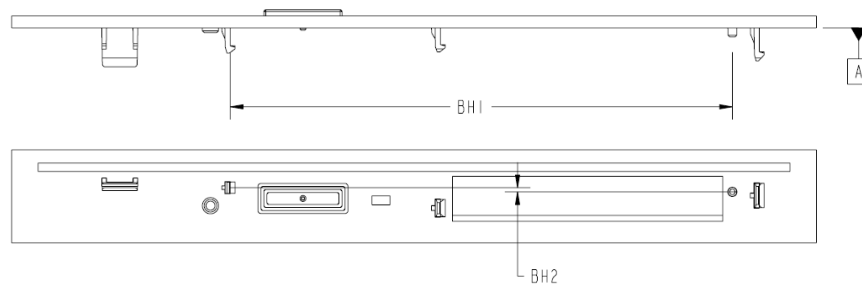

Figure 8.8

Designator	Dimension (mm)	Tolerance (mm)	Notes
BH1	83.8	+ .10 / - .00	
BH2	.70	± .10	

### 8.3.5 Bezel Snap Number 4 Definition

#### 8.3.5.1 Snap Dimensions

Snap number four shall be a cantilever snap connector. The dimensions are specified in Figure 8.9.

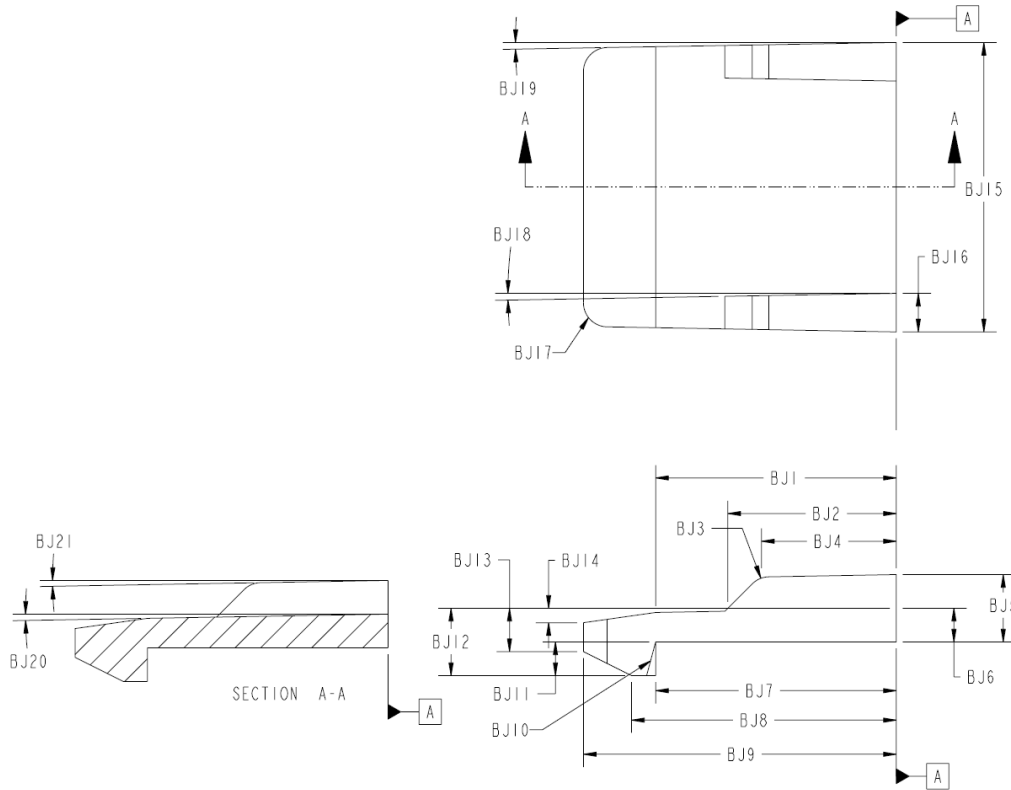

Figure 8.9

Designator	Dimension (mm)	Tolerance (mm)	Notes
BJ1	5.00	±.10	
BJ2	3.50	±.10	
BJ3	2 - R0.5		Radius
BJ4	2.80	±.10	
BJ5	1.4	+.00/-.10	
BJ6	(0.7)		Reference
BJ7	5.00	+.10/-.00	
BJ8	5.50	±.10	
BJ9	6.50	±.10	
BJ10	0.5°		Max Degrees, draft
BJ11	.70	±.05	
BJ12	1.40	±.10	
BJ13	.90	±.10	
BJ14	.30	±.10	
BJ15	6.00	±.10	
BJ16	2 - .80	±.10	
BJ17	2 - R0.5		Radius
BJ18	1.0°		Degrees, draft
BJ19	1.0°		Degrees, draft
BJ20	1.0°		Degrees, draft
BJ21	1.0°		Degrees, draft

### 8.3.5.2 Location of Snap

The position and location of the snap are specified in Figure 8.10.

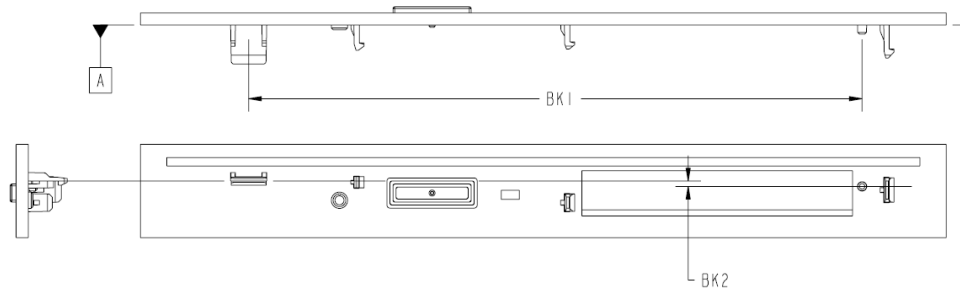

Figure 8.10

Designator	Dimension (mm)	Tolerance (mm)	Notes
BK1	102.0	±.10	
BK2	.90	±.10	

### 8.3.6 Datum A Definition

The plane, Datum A, may not have any feature break its plane from the bezel except for the features defined in this specification that are attached to the bezel.

#### 8.3.6.1 Implementers Note

Flex cables are used to attach the LED and eject buttons. Figure 8.11 shows dimension BL2. Dimension BL2 should be a minimum of 0.7mm for a compliant bezel so that the button may not cross Datum A when pressed. If a bezel supplier cannot meet dimension BL2 specification due to a thin bezel design (causes cosmetic issues, etc.), a bezel designed specifically to meet the drive requirements may be needed.

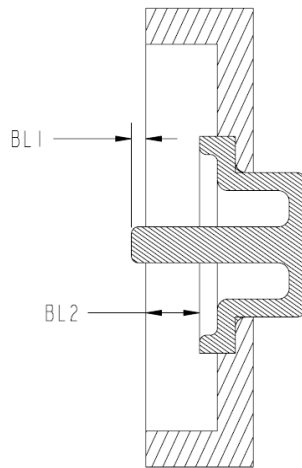

Figure 8.11

Designator	Dimension (mm)	Tolerance (mm)	Notes
BL1	.40	+.00/-.10	
BL2	.7	Min	

8.3.7 Button and LED

8.3.7.1 Location of Button and LED

The button pin and LED's locations are shown in figure 8.12. The button activation pin's length is defined as 0.4 +0.0 /-0.1mm from the back plane of the bezel in Detail A in Figure 8.13.

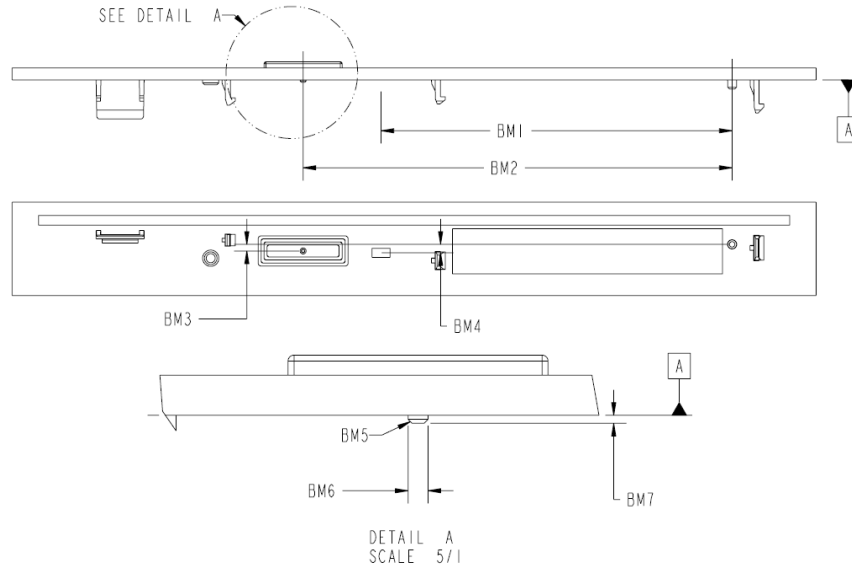

Figure 8.12

Designator	Dimension (mm)	Tolerance (mm)	Notes
BM1	58.5	±.10	
BM2	71.5	±.10	
BM3	1.1	±.10	
BM4	1.4	±.10	
BM5	45° x .20	Min	Degrees
BM6	1.0-1.2		
BM7	0.4	+0.00/-0.10	

**8.3.8 Emergency Eject**

**8.3.8.1 Emergency Eject Hole Location**

The location of the emergency eject hole is described in Figure 8.13.

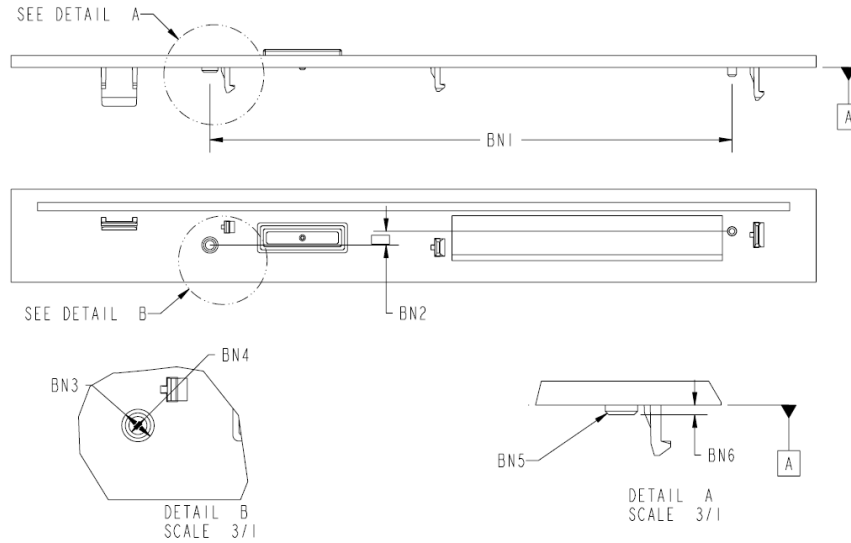

Figure 8.13

Designator	Dimension (mm)	Tolerance (mm)	Notes
BN1	86.9	±.10	
BN2	2.3	±.10	
BN3	2.7	±.10	
BN4	1.5	±.10	
BN5	45° X 0.3		Degrees
BN6	0.8	±.10	

**8.3.8.2 Emergency Eject Tube**

The emergency eject tube is defined as a cylindrical protrusion behind the emergency eject hole in the bezel to guide the emergency eject tool to the emergency eject mechanism. This tube's inside diameter is defined to be as large as the emergency eject hole (1.50 +/- 0.1mm). The tube's external diameter shall be 2.7 +/- 0.1 as seen in Detail B of Figure 8.13. The Distance the tube extends from the back of the bezel shall be 0.8 +/- 0.1mm from the back plane of the bezel as seen in Detail B in Figure 8.13.

**8.3.9 Clearance for Pickup Unit Module (PUM)**

**8.3.9.1 Location of Recessed Area**

This is the area in the bezel where there is a defined recess for the PUM. See Figure 8.14.

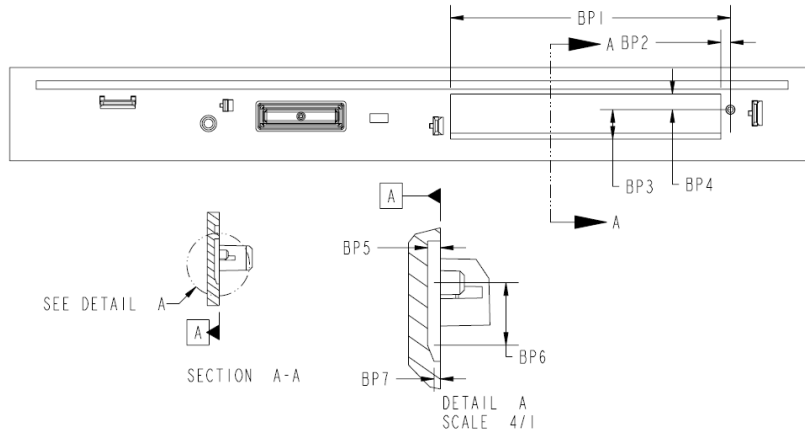

Figure 8.14

Designator	Dimension (mm)	Tolerance (mm)	Notes
BP1	46.6	Min	
BP2	1.6	Max	
BP3	4.9	Min	
BP4	2.6	Min	
BP5	.80	Min	
BP6	3.9	Min	
BP7	0.4	Min	

**8.3.10 Acoustic Noise Pad (Optional)**

This is an optional feature that may be used in bezel construction to dampen the acoustical noise made by the drive. This is an optional feature, however all drives shall be able to function with this feature implemented.

**8.3.10.1 Acoustic Noise Pad Location**

Figure 8.15 describes the placement of the acoustic noise pad. The pad is allowed to have a maximum 0.05mm interference with the chassis of the drive. The Depth of the channel shall be 0.75mm.

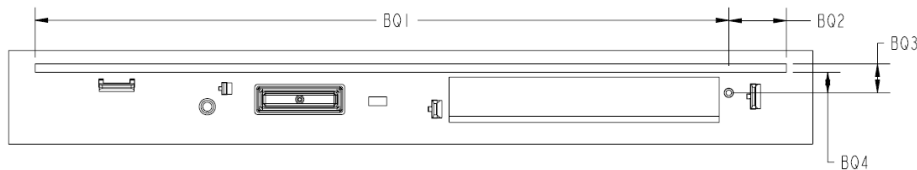

Figure 8.15

Designator	Dimension (mm)	Tolerance (mm)	Notes
BQ1	115.6	±.10	
BQ2	9.6	±.10	
BQ3	4.8	Min	
BQ4	3.4	Min	

**8.3.10.2 Material requirements**

Suppliers shall use the below material requirement or equivalent.

Urethane Material  
 ZUREN-SDCK (Hardness: 9degree)  
 Maker: Bridgestone

**8.4. Tray Side Specifications**

This section describes the features that are on the tray only.

**8.4.1 Grounding Touch point**

The entire case of the optical drive shall provide a path to ground.

**8.4.2 Tray Datum Definition**

Figure 8.16 defines Datum B which nothing except the LED from the tray side is allowed to cross. The LED is defined in section 8.4.2.4 and the PUM is defined in section 8.3.9.1.

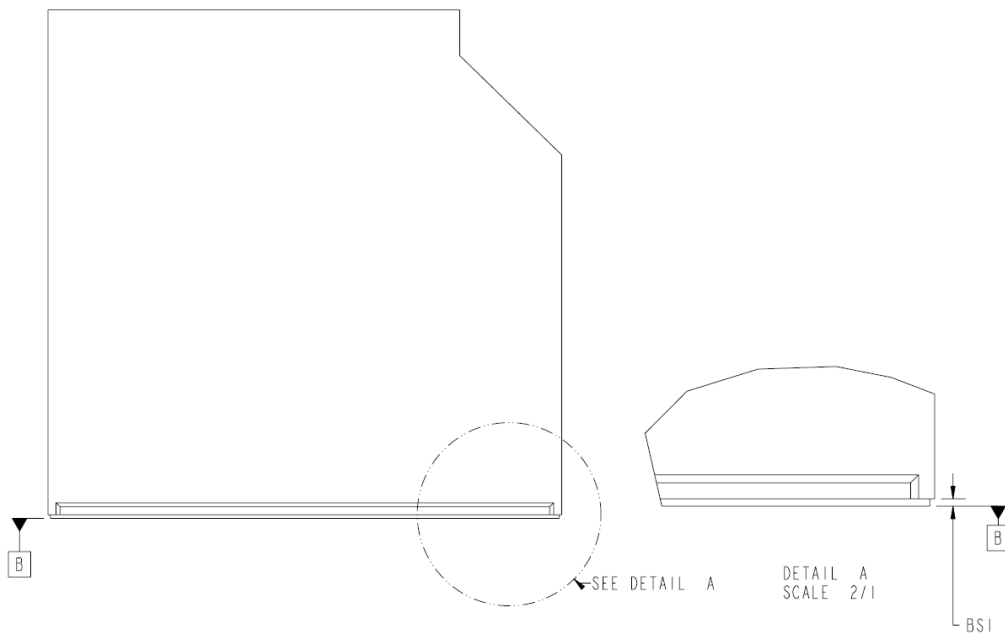

Figure 8.16

Designator	Dimension (mm)	Tolerance (mm)	Notes
BR1	.90	±.20	

#### 8.4.2.1 Tray Protrusion

The tray shall protrude out of the chassis of the drive 0.9mm +/- 0.2mm.

#### 8.4.2.2 Location of Alignment Pin Hole, Switch, and LED

The location of the alignment pin hole switch and LED are specified in Figure 8.17. The crosshatched circle represents the switch, and the crosshatched rectangle represents the LED. The shapes are not intended to define the physical appearance of the switch and/or LED but are placeholders for reference.

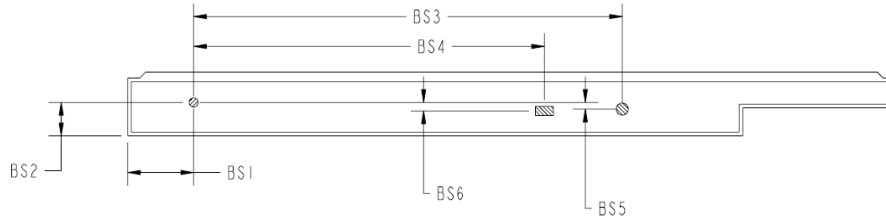

Figure 8.17

Designator	Dimension (mm)	Tolerance (mm)	Notes
BS1	11	±.20	
BS2	5.5	±.20	
BS3	71.5	±.30	
BS4	58.5	±.30	
BS5	1.1	±.30	
BS6	1.4	±.30	

#### 8.4.2.3 Button Position/Activation Points

Figure 8.12 defines the position of the button in the X and Y axis. For the Z-axis the button shall be sub-flush of Datum B by 0.6 +/- 0.15mm. The button shall activate when depressed within a range of 0.05mm to 0.35mm.

#### 8.4.2.4 LED Position

Figure 8.12 defines the position of the LED in the X and Y axis. For the Z-axis the LED may only protrude a maximum of 0.2mm from the front plane of the tray, Datum B. The bezel shall allow for a LED that protrudes this far.

#### 8.4.3 Rib Touch Points

##### 8.4.3.1 Position of Touch Points

Cored bezels are allowed to have ribs for structural support; however those ribs can be coincident or below the surface of Datum A, except in the areas where the spec calls for more of a recess.

#### 8.4.4 Alignment Pin Hole

##### 8.4.4.1 Dimensions of Alignment Pin Hole

The dimension of the hole for the alignment pin is  $\text{Ø}1.5 +0.07/+0.02$ .



**8.5. Implementers Guide**

**8.5.1 Bezel Roll Off Prevention**

The cross hatched areas below represent ribs in a cored bezel that preclude the bezel from being able to be removed easily by rolling downward with a force starting at the wing side of the tray. Figure 8.18 shows the areas where ribs shall be implemented in a cored bezel.

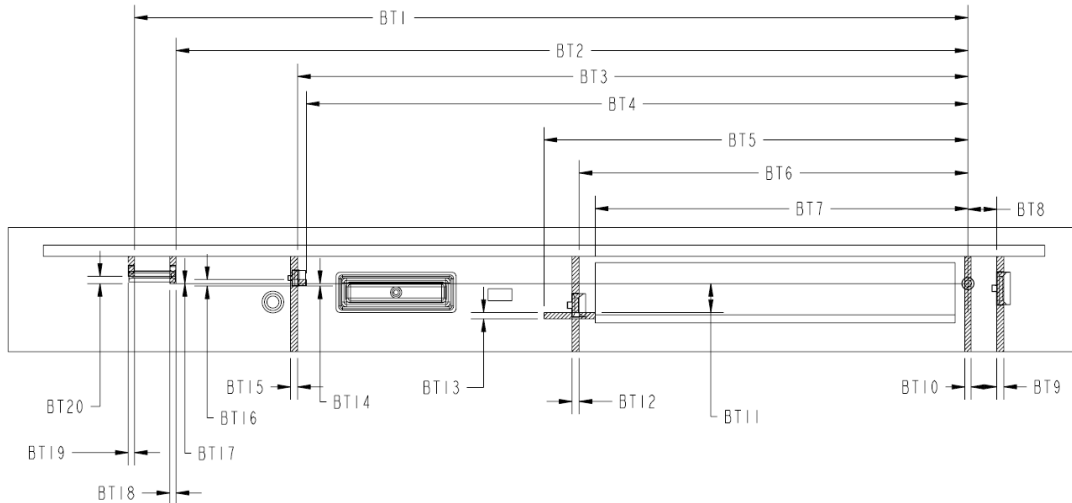

Figure 8.18 Areas where ribs shall be implemented in a cored bezel

Designator	Dimension (mm)	Tolerance (mm)	Notes
BT1	104.2		
BT2	99		
BT3	83.8		
BT4	81.5		
BT5	53		
BT6	48.6		
BT7	46.6		
BT8	3.6		
BT9	0.9		
BT10	0.8		
BT11	3.6		
BT12	0.9		
BT13	0.8		
BT14	0.3		
BT15	0.9		
BT16	0.8		
BT17	0.0		
BT18	0.8		
BT19	0.8		
BT20	0.9		