

SFF Committee

SFF-8248

Specification for

2.5" Form Factor w/Combo Connector inc USB Micro-B Receptacle

The 2.5" specifications were standardized as EIA-720-A 2007/02

Subsequent to that date, this specification was developed.

Standardized as EIA-720-B 2016/01 at Rev 1.0 dated August 30, 2014

SFF specifications are available at <http://www.snia.org/sff/specifications>
or <ftp://ftp.seagate.com/sff>

This specification was developed by the SFF Committee prior to it becoming the SFF TA (Technology Affiliate) TWG (Technical Working Group) of SNIA (Storage Networking Industry Association).

The information below should be used instead of the equivalent herein.

POINTS OF CONTACT:

Chairman SFF TA TWG
Email: SFF-Chair@snia.org

If you are interested in participating in the activities of the SFF TWG, the membership application can be found at:

<http://www.snia.org/sff/join>

The complete list of SFF Specifications which have been completed or are currently being worked on can be found at:

<http://www.snia.org/sff/specifications/SFF-8000.TXT>

The operations which complement the SNIA's TWG Policies & Procedures to guide the SFF TWG can be found at:

<http://www.snia.org/sff/specifications/SFF-8032.PDF>

Suggestions for improvement of this specification will be welcome, they should be submitted to:

<http://www.snia.org/feedback>

SFF Committee documentation may be purchased in hard copy or electronic form.
SFF specifications are available at <ftp://ftp.seagate.com/sff>

SFF Committee

SFF-8248

Specification for

2.5" Form Factor w/Combo Connector inc USB Micro-B Receptacle

Rev 1.0

August 30 2014

Secretariat: SFF Committee

Abstract: This specification defines the dimensions for location of the combination connector including a USB 3.0 Micro-B receptacle on the 2.5" Drive Form Factor.

This specification provides a common reference for systems manufacturers, system integrators, and suppliers. This is an internal working specification of the SFF Committee, an industry ad hoc group.

This specification is made available for public review, and written comments are solicited from readers. Comments received by the members will be considered for inclusion in future revisions of this specification.

Support: This specification is supported by the identified member companies of the SFF Committee.

POINTS OF CONTACT:

Alvin Cox
Seagate Technology, LLC
10321 West Reno Avenue
Oklahoma City OK 73157

Ph: 405-206-4809
alvin dot cox at seagate dot com

I. Dal Allan
Chairman SFF Committee
14426 Black Walnut Court
Saratoga CA 95070

Ph: 408-867-6630
endlcom at acm dot org

EXPRESSION OF SUPPORT BY MANUFACTURERS

The following member companies of the SFF Committee voted in favor of this industry specification.

Cinch
EMC
FCI
Foxconn
Hitachi GST
Seagate
Volex

The following member companies of the SFF Committee voted to abstain on this industry specification.

Finisar
LSI
Molex
NetApp
NetLogic uSyst
Sandisk
Toshiba
Tyco

Update History

Rev 0.5 (September 15, 2010)

- Updated the table entries as indicated in red text (A3, A11, A21, and A22) and replaced all figures.
- The reference to the mounting hole and the USB connector moved to the top of the tongue to the bottom.
- The dimensioning of the power section to USB section was revised.

Rev 0.6 (October 12, 2010)

- Updated figures to remove USB 3.0 connector protrusion.
- Deleted A22 dimension and changed A15.

Rev 0.8 (January 6, 2011)

- Changed connector name to "combination connector including a USB 3.0 Micro-B receptacle" and made minor editorial changes to text.

Rev 0.9 (February 12, 2014)

- Editorial update for forwarding to EIA.

Rev 1.0 (August 30, 2014)

- Editorial changes for consistency between specifications in revised EIA-720.

Foreword

The development work on this specification was done by the SFF Committee, an industry group. The membership of the committee since its formation in August 1990 has included a mix of companies which are leaders across the industry.

When 2 1/2" diameter disk drives were introduced, there was no commonality on external dimensions e.g. physical size, mounting locations, connector type, connector location, between vendors.

The first use of these disk drives was in specific applications such as laptop portable computers and system integrators worked individually with vendors to develop the packaging. The result was wide diversity, and incompatibility.

The problems faced by integrators, device suppliers, and component suppliers led to the formation of the SFF Committee as an industry ad hoc group to address the marketing and engineering considerations of the emerging new technology.

During the development of the form factor definitions, other activities were suggested because participants in the SFF Committee faced more problems than the physical form factors of disk drives. In November 1992, the charter was expanded to address any issues of general interest and concern to the storage industry. The SFF Committee became a forum for resolving industry issues that are either not addressed by the standards process or need an immediate solution.

Those companies which have agreed to support a specification are identified in the first pages of each SFF Specification. Industry consensus is not an essential requirement to publish an SFF Specification because it is recognized that in an emerging product area, there is room for more than one approach. By making the documentation on competing proposals available, an integrator can examine the alternatives available and select the product that is felt to be most suitable.

SFF Committee meetings are held during T10 weeks (see www.t10.org), and Specific Subject Working Groups are held at the convenience of the participants. Material presented at SFF Committee meetings becomes public domain, and there are no restrictions on the open mailing of material presented at committee meetings.

Most of the specifications developed by the SFF Committee have either been incorporated into standards or adopted as standards by EIA (Electronic Industries Association), ANSI (American National Standards Institute) and IEC (International Electrotechnical Commission).

If you are interested in participating or wish to follow the activities of the SFF Committee, the signup for membership and/or documentation can be found at:
www.sffcommittee.com/ie/join.html

The complete list of SFF Specifications which have been completed or are currently being worked on by the SFF Committee can be found at:
<ftp://ftp.seagate.com/sff/SFF-8000.TXT>

If you wish to know more about the SFF Committee, the principles which guide the activities can be found at:
<ftp://ftp.seagate.com/sff/SFF-8032.TXT>

Suggestions for improvement of this specification will be welcome. They should be sent to the SFF Committee, 14426 Black Walnut Ct, Saratoga, CA 95070.

TABLE OF CONTENTS

1. Scope of 8248	7
1.1 Application Specific Criteria	7
2. References	7
2.1 Industry Documents	7
2.2 SFF Specifications	7
2.3 Sources	7
2.4 Conventions	7
3. General Description	8

FIGURES

Figure 3-1 Option 1: 2.5" Drive Form Factor with the Combination Connector including a USB 3.0 Micro-B Receptacle Referenced to Bottom Mounting Screws	10
Figure 3-2 Option 2: 2.5" Drive Form Factor with the Combination Connector including a USB 3.0 Micro-B Receptacle Referenced to Side Mounting Screws	11

TABLES

Table 3-1 USB 3.0 Combination Connector Location	9
--	---

SFF Committee --

2.5" Form Factor w/Combo Connector inc USB Micro-B Receptacle

1. Scope of 8248

This specification defines the dimensions and tolerances for location of the combination connector including a USB 3.0 Micro-B receptacle on SFF-8201 compliant 2.5" form factor drives.

1.1 Application Specific Criteria

The environment for the 2.5" Drive Form Factor is any computer, cabinet, or enclosure connecting to one or more drives in a restricted packaging environment.

The combination connector including a USB 3.0 Micro-B receptacle provides blind mate features plus extra power and feature pins on an additional connector section that is similar to the SATA connector power section. The drive may be used with a special backplane connector that allows support of an enhanced feature set. Alternately, it may be used with a USB cable having a Micro-B plug (and a standard SATA power cable, if required), although this configuration does not provide connections for the enhanced feature set.

The connector nominally protrudes 0.3 mm (0.012") beyond the drive form factor connector end.

2. References

The SFF Committee activities support the requirements of the storage industry, and it is involved with several standards.

2.1 Industry Documents

The following standards are relevant to this specification:

- ASME Y14.5M Dimensioning and Tolerancing
- Universal Serial Bus 3.0 Specification
- Serial ATA Revision 3.0 (SATA), 2 June 2009
- SFF-8458 Combination Connector Including a USB 3.0 Micro-B Receptacle

2.2 SFF Specifications

There are several projects active within the SFF Committee. The complete list of specifications which have been completed or are still being worked on are listed in the specification at <ftp://ftp.seagate.com/sff/SFF-8000.TXT>

2.3 Sources

Those who join the SFF Committee as an Observer or Member receive electronic copies of the minutes and SFF specifications (<http://www.sffcommittee.com/ie/join.html>).

Copies of ANSI standards may be purchased from the InterNational Committee for Information Technology Standards (www.techstreet.com/incitsgate.html).

2.4 Conventions

The dimensioning conventions are described in ASME-Y14.5M, Geometric Dimensioning and Tolerancing. All dimensions are in millimeters, which are the controlling dimensional units (if inches are supplied, they are for guidance only).

The ISO convention of numbering is used i.e., the thousands and higher multiples are separated by a space and a period is used as the decimal point. This is equivalent to the English/American convention of a comma and a period.

American	French	ISO
0.6	0,6	0.6
1,000	1 000	1 000
1,323,462.9	1 323 462,9	1 323 462.9

3. General Description

SFF-8248 defines the location of the combination connector including a USB 3.0 Micro-B receptacle on the 2.5" Drive Form Factor. The connector nominally protrudes 0.3 mm (0.012") beyond the drive form factor connector end.

This specification defines a drive that can be directly inserted into the backplane of a cabinet, without the need for a cable, and provides information necessary to assist manufacturers in the systems integration of small form factor drives. Alternately, cables may be used to supply power and to connect to the data port(s) of the drive. This specification allows only one location for the interface connector on the drive. The location is similar to that of the Serial ATA (SATA) connector location such that migration to USB 3.0 may be done with minimal mechanical changes to the system. Additional contacts are added on the power connector on the opposite side of the standard SATA power pins so that a standard power cable may be used or enhanced features may be incorporated with the use of a backplane connector. See SFF-8458 for the Combination Connector Including a USB 3.0 Micro-B Receptacle mechanical and enhanced feature set details.

Provisions exist in the combination connector for improved mating via guides. Staggered pin lengths incorporate provision for mating ground prior to mating any other signals.

Care must be taken in the application of this drive so that excessive stress is not exerted on the connector. Backplane configurations must pay particular attention so that the connector is not damaged due to excessive side loading, compressive forces, or from supporting the weight of the device.

For a drive that can be directly inserted into the backplane of a cabinet this specification references dimensions for Option 1, the form factor bottom mounting hole or Option 2, the form factor side mounting hole. The optional approach prevents excessive tolerance stack-up between the two mounting screw locations when the connector is referenced to only one of the mounting screw locations. A drive may comply with both options but the systems application must choose either Option 1 or Option 2.

TABLE 3-1 USB 3.0 COMBINATION CONNECTOR LOCATION

Dimension	Millimeters	Inches
A 1	69.85	2.750
A 2	47.30	1.862
A 3	36.52	1.438
A 4	0.40	0.016
A 5	4.00	0.157
A 6	0.76	0.030
A 7	3.50	0.138
A 8	9.40	0.370
A 9	0.25	0.010
A10	1.00	0.039
A11	3.23	0.127
A12	0.38	0.015
A13	13.43	0.529
A14	41.34	1.628
A15	2.50	0.098
A16	1.00	0.039
A17	1.00	0.039
A18	0.30	0.012
A19	1.00	0.039
A20	0.20	0.008
A21	0.32	0.013

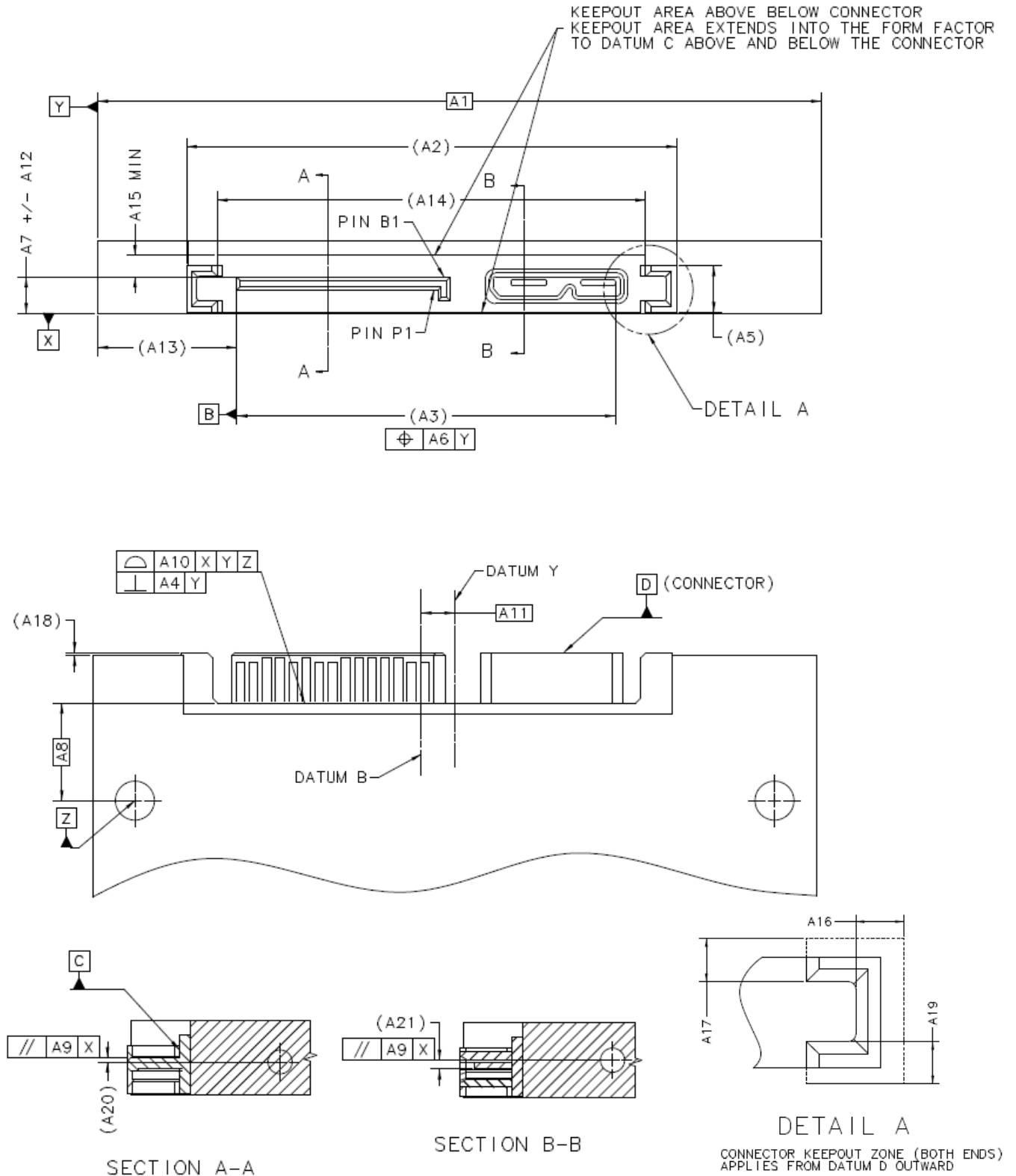

FIGURE 3-1 OPTION 1: 2.5" DRIVE FORM FACTOR WITH THE COMBINATION CONNECTOR INCLUDING A USB 3.0 MICRO-B RECEPTACLE REFERENCED TO BOTTOM MOUNTING SCREWS

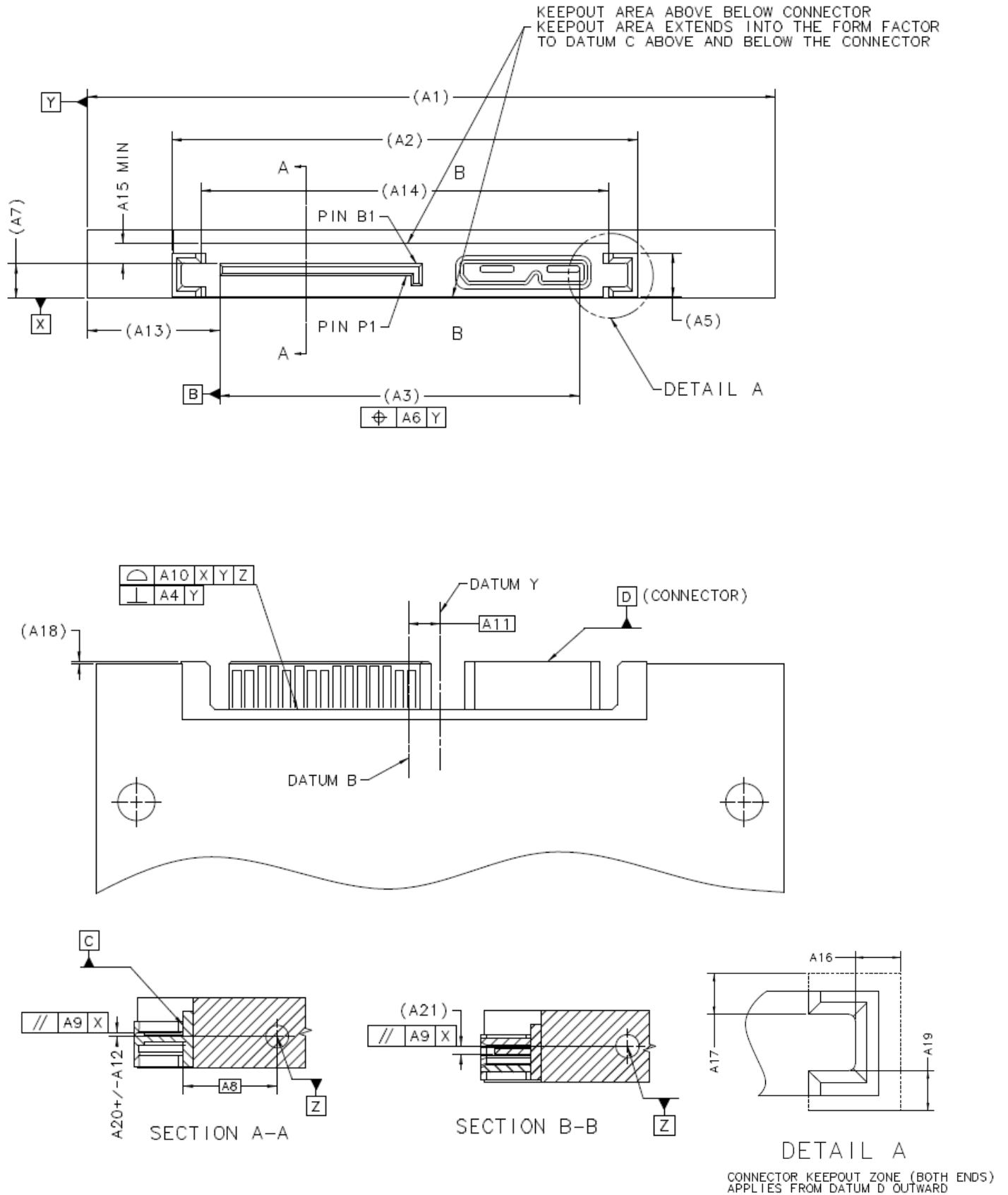

FIGURE 3-2 OPTION 2: 2.5" DRIVE FORM FACTOR WITH THE COMBINATION CONNECTOR INCLUDING A USB 3.0 MICRO-B RECEPTACLE REFERENCED TO SIDE MOUNTING SCREWS