

SFF Committee
SFF-8222
Specification for
2.5" Form Factor Drive with SCA-2 Connector

Standardized as EIA-720-A 2007/02 at Rev 2.1 dated July 16, 2004

This specification was submitted as a project to the Electronic Industries Alliance by being incorporated into SFF-8200, and was Expired at that time.

EIA standards can be purchased from <http://global.ihs.com/>

Revised as EIA-720-B 2016/01 at Rev 2.3 dated August 30, 2014

SFF specifications are available at <http://www.snia.org/sff/specifications>
or <ftp://ftp.seagate.com/sff>

This specification was developed by the SFF Committee prior to it becoming the SFF TA (Technology Affiliate) TWG (Technical Working Group) of SNIA (Storage Networking Industry Association).

The information below should be used instead of the equivalent herein.

POINTS OF CONTACT:

Chairman SFF TA TWG
Email: SFF-Chair@snia.org

If you are interested in participating in the activities of the SFF TWG, the membership application can be found at:

<http://www.snia.org/sff/join>

The complete list of SFF Specifications which have been completed or are currently being worked on can be found at:

<http://www.snia.org/sff/specifications/SFF-8000.TXT>

The operations which complement the SNIA's TWG Policies & Procedures to guide the SFF TWG can be found at:

<http://www.snia.org/sff/specifications/SFF-8032.PDF>

Suggestions for improvement of this specification will be welcome, they should be submitted to:

<http://www.snia.org/feedback>

SFF Committee documentation may be purchased in hard copy or electronic form.
SFF specifications are available at <ftp://ftp.seagate.com/sff>

SFF Committee

SFF-8222

Specification for

2.5" Form Factor Drive with SCA-2 Connector

Rev 2.3 August 30 2014

Secretariat: SFF Committee

Abstract: This specification defines the requirements for the location of the SCA-2 connector on the 2.5" Drive Form Factors. Dimensions are referenced either from the form factor bottom mounting hole or the form factor side mounting hole, depending on the application.

This specification provides a common reference for systems manufacturers, system integrators, and suppliers. This is an internal working specification of the SFF Committee, an industry ad hoc group.

This specification is made available for public review, and written comments are solicited from readers. Comments received by the members will be considered for inclusion in future revisions of this specification.

Support: This specification is supported by the identified member companies of the SFF Committee.

POINTS OF CONTACT:

Alvin Cox
Seagate Technology, LLC
10321 West Reno Avenue
Oklahoma City OK 73157

Ph: 405-206-4809
alvin dot cox at seagate dot com

I. Dal Allan
Chairman SFF Committee
14426 Black Walnut Court
Saratoga CA 95070

Ph: 408-867-6630
endlcom at acm dot org

EXPRESSION OF SUPPORT BY MANUFACTURERS

The following member companies of the SFF Committee voted in favor of this industry specification.

Adaptec
ENDL
FCI/Berg
Foxconn Int'l
Fujitsu CPA
Hewlett Packard
Hitachi Cable
Hitachi GST
IBM
Intel
Madison Cable
Molex
Nexans
Seagate
Sun Microsystems
Toshiba America
Tyco AMP
Unisys
Xyratex

The following member companies of the SFF Committee voted to abstain on this industry specification.

Agilent
Amphenol
Dell
EMC
Fujitsu Compnts
Hitachi America
Infineon
Maxtor
Micrel
Picolight
Vitesse Semi

Change History

2.2 Rev (February 12, 2014)

- Rev 2.1 July 2004 contents incorporated in current template.

Rev 2.3 (August 30, 2014)

- Editorial changes for consistency between specifications in revised EIA-720.

Foreword

The development work on this specification was done by the SFF Committee, an industry group. The membership of the committee since its formation in August 1990 has included a mix of companies which are leaders across the industry.

When 2 1/2" diameter disk drives were introduced, there was no commonality on external dimensions e.g. physical size, mounting locations, connector type, connector location, between vendors.

The first use of these disk drives was in specific applications such as laptop portable computers and system integrators worked individually with vendors to develop the packaging. The result was wide diversity, and incompatibility.

The problems faced by integrators, device suppliers, and component suppliers led to the formation of the SFF Committee as an industry ad hoc group to address the marketing and engineering considerations of the emerging new technology.

During the development of the form factor definitions, other activities were suggested because participants in the SFF Committee faced more problems than the physical form factors of disk drives. In November 1992, the charter was expanded to address any issues of general interest and concern to the storage industry. The SFF Committee became a forum for resolving industry issues that are either not addressed by the standards process or need an immediate solution.

Those companies which have agreed to support a specification are identified in the first pages of each SFF Specification. Industry consensus is not an essential requirement to publish an SFF Specification because it is recognized that in an emerging product area, there is room for more than one approach. By making the documentation on competing proposals available, an integrator can examine the alternatives available and select the product that is felt to be most suitable.

SFF Committee meetings are held during T10 weeks (see www.t10.org), and Specific Subject Working Groups are held at the convenience of the participants. Material presented at SFF Committee meetings becomes public domain, and there are no restrictions on the open mailing of material presented at committee meetings.

Most of the specifications developed by the SFF Committee have either been incorporated into standards or adopted as standards by EIA (Electronic Industries Association), ANSI (American National Standards Institute) and IEC (International Electrotechnical Commission).

If you are interested in participating or wish to follow the activities of the SFF Committee, the signup for membership and/or documentation can be found at:
www.sffcommittee.com/ie/join.html

The complete list of SFF Specifications which have been completed or are currently being worked on by the SFF Committee can be found at:
<ftp://ftp.seagate.com/sff/SFF-8000.TXT>

If you wish to know more about the SFF Committee, the principles which guide the activities can be found at:
<ftp://ftp.seagate.com/sff/SFF-8032.TXT>

Suggestions for improvement of this specification will be welcome. They should be sent to the SFF Committee, 14426 Black Walnut Ct, Saratoga, CA 95070.

TABLE OF CONTENTS

1.	Scope of 8222	7
1.1	Application Environment	7
2.	References	7
2.1	Industry Documents	7
2.2	SFF Specifications	7
2.3	Sources	7
2.4	Conventions	7
3.	General Description	8

FIGURES

Figure 3-1 Application Option 1: 2.5" Drive Form Factor with SCA-2 Connector Referenced to Bottom Mounting Screw		9
Figure 3-2 Application Option 2: 2.5" Drive Form Factor with SCA-2 Connector Referenced to Side Mounting Screw		10

TABLES

Table 3-1 SCA-2 Connector Location		8
------------------------------------	--	---

SFF Committee --

2.5" Form Factor Drive w/SCA-2 Connector

1. Scope of 8222

This specification defines the dimensions and tolerances for location of the SCA-2 connector on SFF-8201 compliant 2.5" form factor drives.

1.1 Application Environment

The environment for the 2.5" Drive Form Factor is any computer, cabinet, or enclosure connecting to one or more drives in a restricted packaging environment.

The purpose of this Specification is to provide information that will assist vendors to design products that can fit the same packaging envelope.

2. References

The SFF Committee activities support the requirements of the storage industry, and it is involved with several standards.

2.1 Industry Documents

The following standards are relevant to many SFF Specifications.

- ASME Y14.5M Dimensioning and Tolerancing
- X3.131R-1994 SCSI-2 Small Computer System Interface
- X3.253-1995 SPI (SCSI-3 Parallel Interface)
- X3.302-xxxx SPI-2 (SCSI-3 Parallel Interface -2)
- X3.230-199x FC-PH Physical Interface
- X3T11/0960 FC-AL Arbitrated Loop
- X3T10/0993 FCP Fibre Channel Protocol (X3T11 FC-PH)
- EIA PN-3651 Detail Specification for Trapezoidal Connector 0.50" Pitch used with Single Connector Attach -2.
- EIA-720 Detail, SFF 2.5" Disk Drives
- SFF-8201 Form Factor of 2.5" Disk Drives

2.2 SFF Specifications

There are several projects active within the SFF Committee. The complete list of specifications which have been completed or are still being worked on are listed in the specification at <ftp://ftp.seagate.com/sff/SFF-8000.TXT>

2.3 Sources

Those who join the SFF Committee as an Observer or Member receive electronic copies of the minutes and SFF specifications (<http://www.sffcommittee.com/ie/join.html>).

Copies of ANSI standards may be purchased from the InterNational Committee for Information Technology Standards (<http://www.techstreet.com/incitsgate.tmp>).

2.4 Conventions

The dimensioning conventions are described in ASME-Y14.5M, Geometric Dimensioning and Tolerancing. All dimensions are in millimeters, which are the controlling dimensional units (if inches are supplied, they are for guidance only).

The ISO convention of numbering is used i.e., the thousands and higher multiples are separated by a space and a period is used as the decimal point. This is equivalent to the English/American convention of a comma and a period.

American	French	ISO
0.6	0,6	0.6
1,000	1 000	1 000
1,323,462.9	1 323 462,9	1 323 462.9

3. General Description

This specification defines the location of the SCA-2 (Single Connector Attach) interface connectors for parallel SCSI (80-pin) and Fibre Channel (40-pin) on the 2.5" Drive Form Factors.

This specification defines requirements for a drive that can be directly inserted into the backplane of a cabinet, without the need for a cable, and provides information necessary to assist manufacturers in the systems integration of small form factor disk drives. This specification allows only one location for the interface connector on the drive for any specific application. In Application Option 1 where bottom mounting is used, the bottom mounting hole provides the reference for dimensions. In Application Option 2 where side mounting is used, the side mounting hole provides the reference for dimensions. A drive may comply with both options but the systems application must choose either Option 1 or Option 2.

This specification methodology prevents excessive tolerance stack-up between the two mounting screw locations when the connector is referenced to only one mounting screw location and the form factor drawing is used to determine the location of the connector to the other mounting screw location.

Provision exists in the SCA-2 connector for improved mating via guides that incorporate provision for mating ground prior to mating any other signals.

Care must be taken in the application of this drive so that excessive stress is not exerted on the connector. Backplane configurations must pay particular attention so that the connector is not damaged due to excessive side loading, compressive forces, or from supporting the weight of the device.

Table 3-1 defines the dimensions associated with the positioning of the connector on the drive as illustrated in Figure 3-1 or Figure 3-2.

TABLE 3-1 SCA-2 CONNECTOR LOCATION

Dimension	Millimeters		Comments
A 1	69.85	2.750	
A 2	66.50	2.618	80-position
A 2	41.10	1.618	40-position
A 3	1.00	0.039	
A 4	0.35	0.014	
A 5	7.00	0.276	
A 6	1.00	0.039	
A 7	4.00	0.157	
A 8	24.00	0.945	
A 9	0.35	0.014	
A10	0.50	0.020	

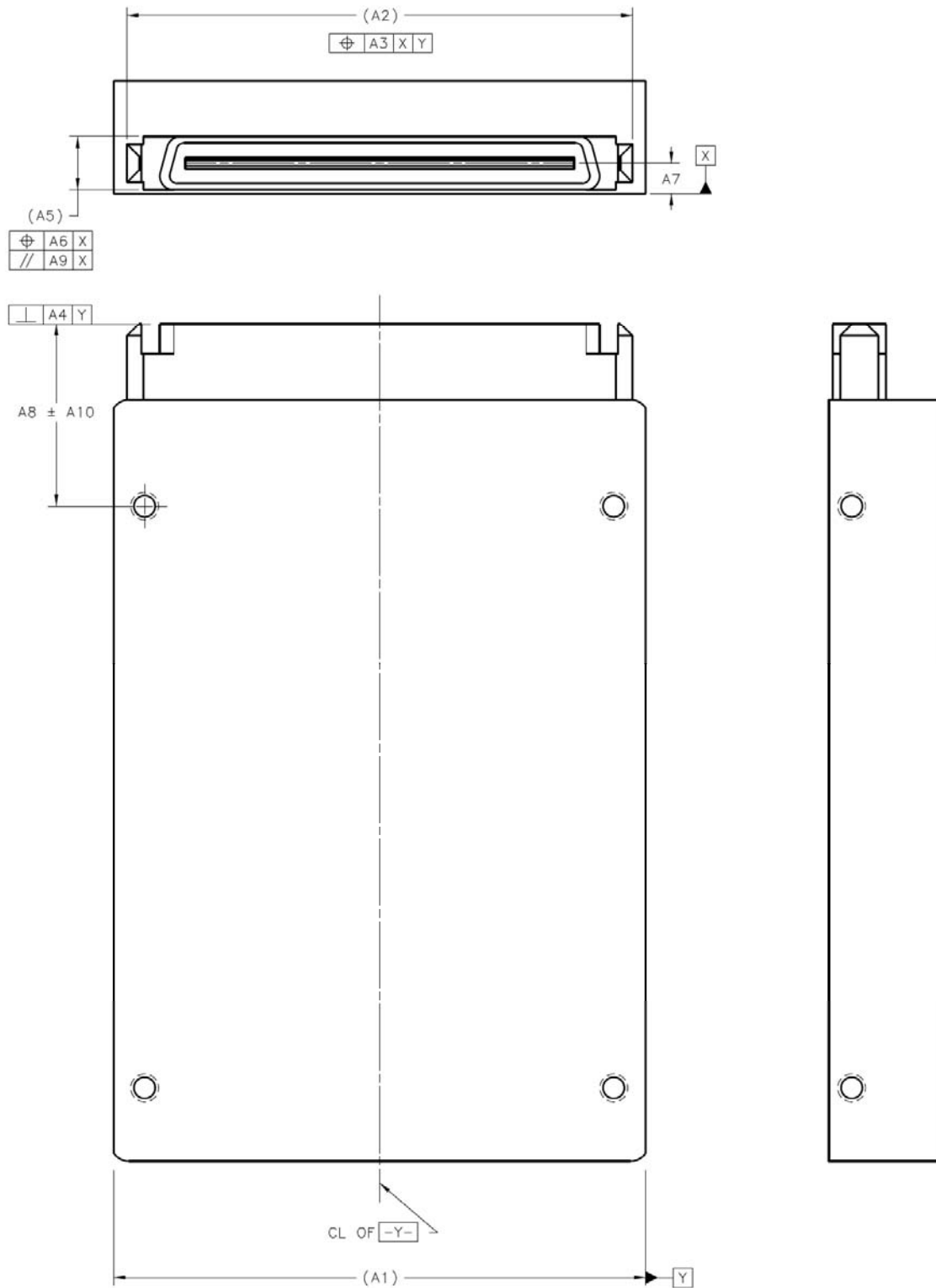

FIGURE 3-1 APPLICATION OPTION 1: 2.5" DRIVE FORM FACTOR WITH SCA-2 CONNECTOR REFERENCED TO BOTTOM MOUNTING SCREW

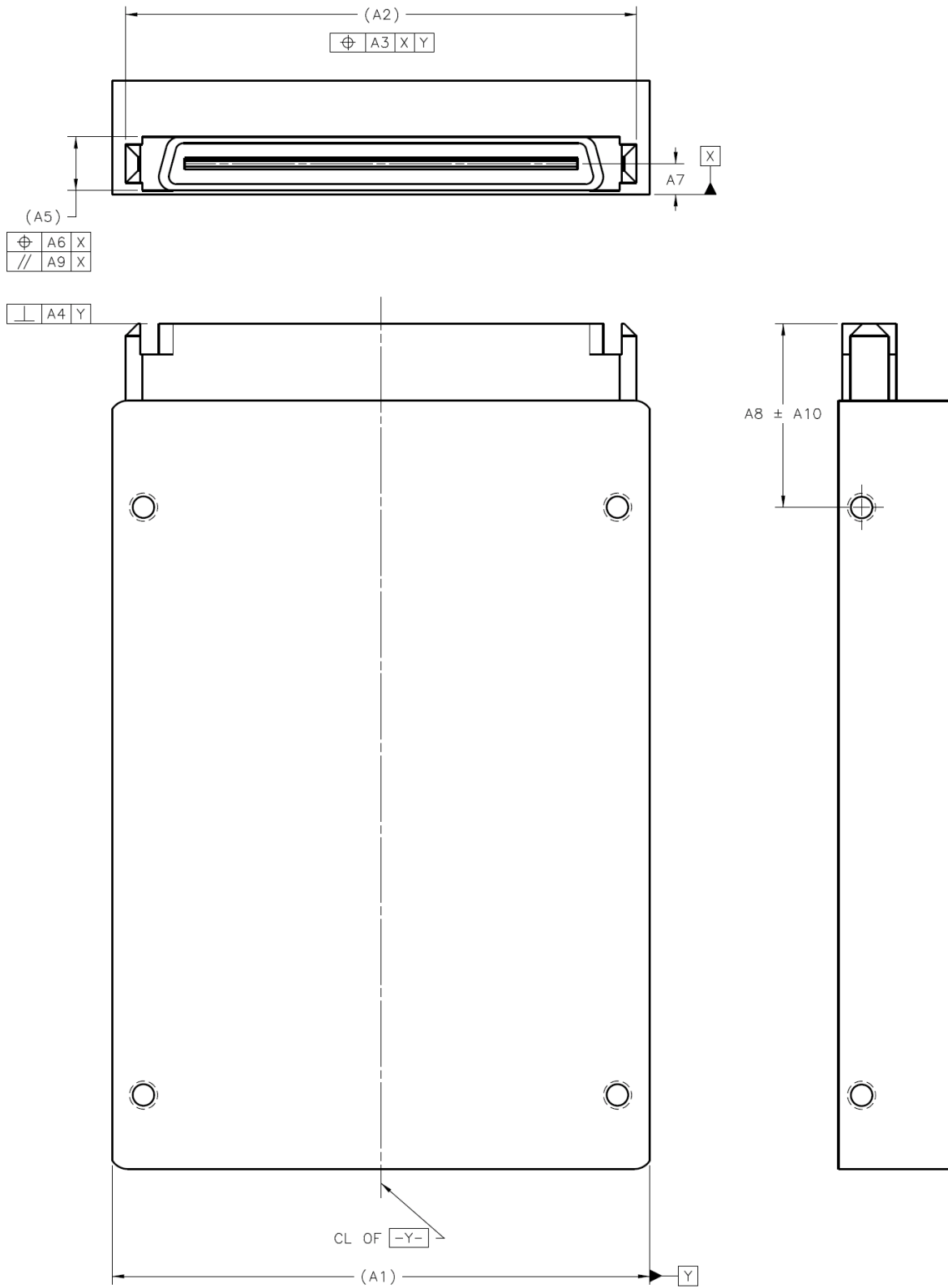

FIGURE 3-2 APPLICATION OPTION 2: 2.5" DRIVE FORM FACTOR WITH SCA-2 CONNECTOR REFERENCED TO SIDE MOUNTING SCREW