

SFF specifications are available at <http://www.snia.org/sff/specifications>
or <ftp://ftp.seagate.com/sff>

This specification was developed by the SFF Committee prior to it becoming the SFF TA (Technology Affiliate) TWG (Technical Working Group) of SNIA (Storage Networking Industry Association).

The information below should be used instead of the equivalent herein.

POINTS OF CONTACT:

Chairman SFF TA TWG
Email: SFF-Chair@snia.org

If you are interested in participating in the activities of the SFF TWG, the membership application can be found at:

<http://www.snia.org/sff/join>

The complete list of SFF Specifications which have been completed or are currently being worked on can be found at:

<http://www.snia.org/sff/specifications/SFF-8000.TXT>

The operations which complement the SNIA's TWG Policies & Procedures to guide the SFF TWG can be found at:

<http://www.snia.org/sff/specifications/SFF-8032.PDF>

Suggestions for improvement of this specification will be welcome, they should be submitted to:

<http://www.snia.org/feedback>

SFF Committee documentation may be purchased in hard copy or electronic form.
SFF specifications are available at <ftp://ftp.seagate.com/sff>

SFF Committee

SFF-8095 Specification

for

Tether Testing Procedure

Rev 0.6 May 13, 2011

Secretariat: SFF Committee

Abstract: This specification defines the set-up and procedure for testing the tether attachment on Mini Multilane and may be applicable to other connector types.

This document provides a common specification for systems manufacturers, system integrators, and suppliers of drives. This is an internal working document of the SFF Committee, an industry ad hoc group.

This specification is made available for public review, and written comments are solicited from readers. Comments received by the members will be considered for inclusion in future revisions of this specification.

Support: This specification is supported by the identified member companies of the SFF Committee.

POINTS OF CONTACT:

Dan Gorenc
TE Connectivity
3101 Fulling Mill Rd
Middletown PA 17057

717-986-3518
daniel dot gorenc at te dot com

I. Dal Allan
Chairman SFF Committee
14426 Black Walnut Court
Saratoga CA 95070

408-867-6630
endlcom at acm dot org

EXPRESSION OF SUPPORT BY MANUFACTURERS

The following member companies of the SFF Committee voted in favor of this industry specification.

Amphenol
EMC
FCI
Foxconn
Hewlett Packard
ICT-Lanto
Molex
NetApp
Panduit
Seagate
TE Connectivity
Volex

The following member companies of the SFF Committee voted to abstain on this industry specification.

Cinch
Dell Computer
Finisar
Hitachi GST
Intel
JDS Uniphase
LSI
Luxtera
Mellanox
OpNext
Sandisk
Siemon
Toshiba

Foreword

The development work on this specification was done by the SFF Committee, an industry group. The membership of the committee since its formation in August 1990 has included a mix of companies which are leaders across the industry.

When 2 1/2" diameter disk drives were introduced, there was no commonality on external dimensions e.g. physical size, mounting locations, connector type, and connector location, between vendors.

The first use of these disk drives was in specific applications such as laptop portable computers and system integrators worked individually with vendors to develop the packaging. The result was wide diversity, and incompatibility.

The problems faced by integrators, device suppliers, and component suppliers led to the formation of the SFF Committee as an industry ad hoc group to address the marketing and engineering considerations of the emerging new technology.

During the development of the form factor definitions, other activities were suggested because participants in the SFF Committee faced more problems than the physical form factors of disk drives. In November 1992, the charter was expanded to address any issues of general interest and concern to the storage industry. The SFF Committee became a forum for resolving industry issues that are either not addressed by the standards process or need an immediate solution.

Those companies which have agreed to support a specification are identified in the first pages of each SFF Specification. Industry consensus is not an essential requirement to publish an SFF Specification because it is recognized that in an emerging product area, there is room for more than one approach. By making the documentation on competing proposals available, an integrator can examine the alternatives available and select the product that is felt to be most suitable.

SFF Committee meetings are held during T10 weeks (see www.t10.org), and Specific Subject Working Groups are held at the convenience of the participants. Material presented at SFF Committee meetings becomes public domain, and there are no restrictions on the open mailing of material presented at committee meetings.

Most of the specifications developed by the SFF Committee have either been incorporated into standards or adopted as standards by EIA (Electronic Industries Association), ANSI (American National Standards Institute) and IEC (International Electrotechnical Commission).

If you are interested in participating or wish to follow the activities of the SFF Committee, the signup for membership and/or documentation can be found at:
www.sffcommittee.com/ie/join.html

The complete list of SFF Specifications which have been completed or are currently being worked on by the SFF Committee can be found at:
<ftp://ftp.seagate.com/sff/SFF-8000.TXT>

If you wish to know more about the SFF Committee, the principles which guide the activities can be found at:
<ftp://ftp.seagate.com/sff/SFF-8032.TXT>

Suggestions for improvement of this specification will be welcome. They should be sent to the SFF Committee, 14426 Black Walnut Ct, Saratoga, CA 95070.

TABLE OF CONTENTS

1. Scope 6

 1.1 Description of Clauses..... 6

2. References 6

 2.1 Industry Documents..... 6

 2.2 SFF Specifications..... 6

 2.3 Sources..... 6

 2.4 Definitions..... 7

 2.5 Conventions..... 7

3. General Description 8

4. Test Procedure 8

 4.1 Weighted Tether Test..... 8

 4.2 Test A - 45 Degree Hanging Weight Setup..... 8

 Test B - 45 Degree Rotational Stress Setup..... 9

 4.3 Test C - Perpendicular Hanging Weight Setup..... 10

 4.4 Test D - Perpendicular Rotational Stress Setup..... 10

5. Acceptance Criteria 10

FIGURES

FIGURE 4.1. 45 Degree Hanging Weight Setup 8

FIGURE 4.2. 45 Degree Rotational Stress Setup 9

FIGURE 4.3. Perpendicular Hanging Weight Setup 10

Revision History:

Revision 0.4 May 4 2011

- Abstract, changed 'is applicable' to 'may be applicable'
- updated TOC titles section 4
- Scope, corrected spelling
- 2.1 Industry Standards removed SFF-8147 & SFF-8482, added SFF-8088
- 2.4 changed / symbol to ÷ symbol
- 4.2 changed title
- Figure 4.1 corrected artwork
- 4.3 changed title, added (as specified by end user), added +/- to angles
- 4.4 changed title
- 4.5 changed title, added (as specified by end user), added +/- to angles

SFF Committee --

Tether Testing Procedure

1. Scope

This specification defines the terminology, set-up and test procedure for testing the tether attachment on the Mini Multilane connector. It is designed to give guidance and standardize the testing procedures between manufacturers.

In an effort to standardize the testing, an ad hoc industry group of companies representing system integrators, peripheral suppliers, and component suppliers decided to address the issues involved.

1.1 Description of Clauses

Clause 1 contains the Scope

Clause 2 contains Referenced and Related Standards and SFF Specifications

Clause 3 contains the Definitions and Conventions

Clause 4 contains the General Description

Clause 5 contains the Test Specifications and performance

2. References

The SFF Committee activities support the requirements of the storage industry and it is involved with several standards.

2.1 Industry Documents

The following interface standards and specifications are relevant to this Specification.

- Serial ATA
- Serial Attached SCSI
- SFF-8088
- ASME Y14.5M Dimensioning and Tolerancing

2.2 SFF Specifications

There are several projects active within the SFF Committee. The complete list of specifications which have been completed or are still being worked on are listed in the specification at <ftp://ftp.seagate.com/sff/SFF-8000.TXT>

2.3 Sources

Those who join the SFF Committee as an Observer or Member receive electronic copies of the minutes and SFF specifications (<http://www.sffcommittee.com/ie/join.html>).

Copies of ANSI standards may be purchased from the InterNational Committee for Information Technology Standards (<http://tinyurl.com/c4psg>).

2.4 Definitions

For the purpose of this specification, the following definitions apply:

L (load): L (load) = Max Unlatch Force \div 0.707

Tether: The component used to manually release the latching mechanism.

Unlatching Force: The force needed to release the latching mechanism from the mating shell thus allowing the cable plug to be removed from mating connector.

2.5 Conventions

The ISO convention of numbering is used i.e., the thousands and higher multiples are separated by a space and a period is used as the decimal point. This is equivalent to the English/American convention of a comma and a period.

| English | French | ISO |
|-------------|-------------|-------------|
| 0.6 | 0,6 | 0.6 |
| 1,000 | 1 000 | 1 000 |
| 1,323,462.9 | 1 323 462,9 | 1 323 462.9 |

3. General Description

The following paragraphs give directions on how to set-up and test the tether attachment on the Mini Multilane Connector. They also provide the required acceptance criteria for the tether attachment.

4. Test Procedure

4.1 Weighted Tether Test

With the connector secured as shown in the following figures, apply the "L" (load) to the end of the tether.

4.2 Test A - 45 Degree Hanging Weight Setup

With the "L" (load) hanging from end of tether, allow "L" (load) to hang freely for 5 minutes.

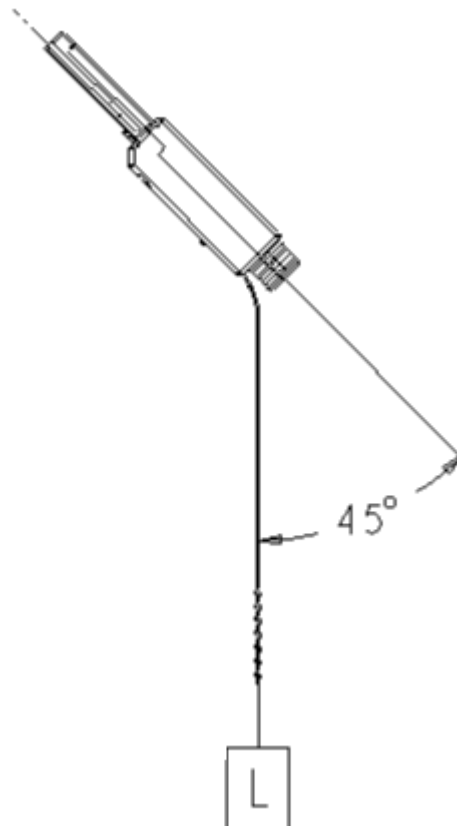

FIGURE 4.1. 45 DEGREE HANGING WEIGHT SETUP

Test B - 45 Degree Rotational Stress Setup

With the "L" (load) hanging from end of tether, rotate the part per test condition A or B about the Y axis (as specified by end user). Rotate the part 5 rotations each direction at a speed of 10 to 20 rotations per minute.

Condition A: +/-45 Degrees Rotation

Condition B: +/-90 Degrees Rotation

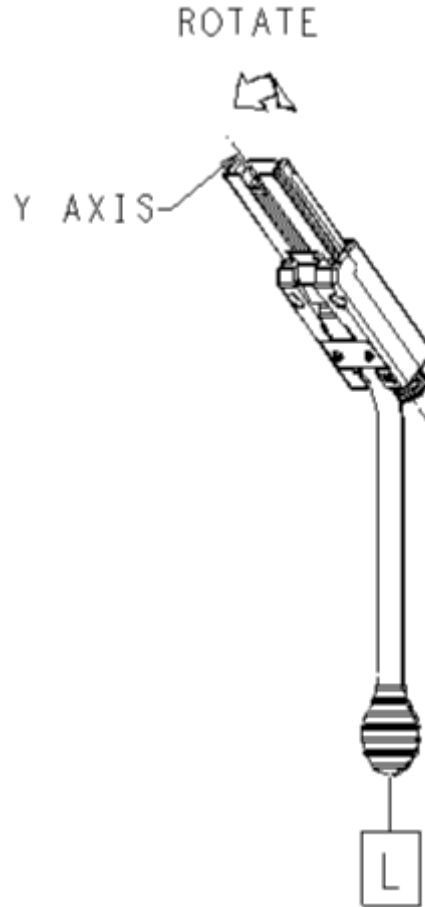

FIGURE 4.2. 45 DEGREE ROTATIONAL STRESS SETUP

4.3 Test C - Perpendicular Hanging Weight Setup

- With the "L" (load) hanging from end of tether, allow "L" (load) to hang freely for 5 minutes.

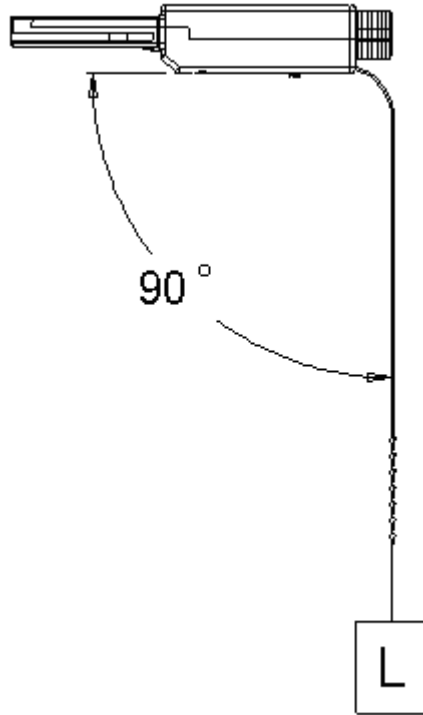

FIGURE 4.3. PERPENDICULAR HANGING WEIGHT SETUP

4.4 Test D - Perpendicular Rotational Stress Setup

- With the "L" (load) hanging from end of tether, rotate the part per test condition A or B (as specified by end user) about its axis, similar to that shown in Figure 4.2. Rotate the part 5 rotations each direction at a speed of 10 to 20 rotations per minute.

Condition A: +/-45 Degrees Rotation

Condition B: +/-90 Degrees Rotation

5. Acceptance Criteria

- Without magnification, no visible cracks or tears should be observed. The latch functions properly when mated/unmated to the Receptacle enclosure for a minimum of 20 cycles.