

SFF specifications are available at <http://www.snia.org/sff/specifications>  
or <ftp://ftp.seagate.com/sff>

**This specification was developed by the SFF Committee prior to it becoming the SFF TA (Technology Affiliate) TWG (Technical Working Group) of SNIA (Storage Networking Industry Association).**

The information below should be used instead of the equivalent herein.

POINTS OF CONTACT:

Chairman SFF TA TWG  
Email: [SFF-Chair@snia.org](mailto:SFF-Chair@snia.org)

If you are interested in participating in the activities of the SFF TWG, the membership application can be found at:

<http://www.snia.org/sff/join>

The complete list of SFF Specifications which have been completed or are currently being worked on can be found at:

<http://www.snia.org/sff/specifications/SFF-8000.TXT>

The operations which complement the SNIA's TWG Policies & Procedures to guide the SFF TWG can be found at:

<http://www.snia.org/sff/specifications/SFF-8032.PDF>

Suggestions for improvement of this specification will be welcome, they should be submitted to:

<http://www.snia.org/feedback>

SFF Committee documentation may be purchased in hard copy or electronic form  
SFF specifications are available at <ftp://ftp.seagate.com/sff>

**SFF Committee**

INF-8475i Specification for

**XPAK Small Formfactor Pluggable Transceiver**

Rev 2.2 December 5, 2002

Secretariat: SFF Committee

Abstract: This specification describes the XPAK Small Formfactor Pluggable Transceiver developed by the MSA (Multiple Source Agreement) group. The following companies were participating members of the MSA.

Blaze	Network Elements
E2O Communications	Opteon
Fujitsu	Picolight
Infineon Technologies	Pine Photonics
Intel	Red Clover Networks
Kodeos Communications	Tyco Electronics
Molex	

This Information Specification was not developed or endorsed by the SFF Committee but was submitted for distribution on the basis that it is of interest to the storage industry. The copyright on the contents remains with the contributor.

Contributors are not required to abide by the SFF patent policy. Readers are advised of the possibility that there may be patent issues associated with an implementation which relies upon the contents of an 'i' specification.

SFF accepts no responsibility for the validity of the contents.

POINTS OF CONTACT:

Jay Neer  
Molex  
399 W Camino Gardens Blvd  
Plaza 4 #103  
Boca Raton FL 33432

561-447-2907x3889

[jneer@molex.com](mailto:jneer@molex.com)

I. Dal Allan  
Chairman SFF Committee  
14426 Black Walnut Court  
Saratoga  
CA 95070

408-867-6630  
408-867-2115Fx  
[endlcom@acm.org](mailto:endlcom@acm.org)

**EXPRESSION OF SUPPORT BY MANUFACTURERS**

The following member companies of the SFF Committee voted in favor of this industry specification.

ENDL  
Sun Microsystems  
Tyco AMP  
Unisys

The following member companies of the SFF Committee voted against this industry specification.

Foxconn Int'l  
Fujitsu CPA

The following member companies of the SFF Committee voted to abstain on this industry specification.

Brocade  
FCI/Berg  
Fiberxon  
Fujitsu Compnts  
Hewlett Packard  
Seagate  
Toshiba America  
Xyratex

If you are not a member of the SFF Committee, but you are interested in participating, the following principles have been reprinted here for your information.

**PRINCIPLES OF THE SFF COMMITTEE**

The SFF Committee is an ad hoc group formed to address storage industry needs in a prompt manner. When formed in 1990, the original goals were limited to defining de facto mechanical envelopes within which disk drives can be developed to fit compact computer and other small products.

Adopting a common industry size simplifies the integration of small drives (2 1/2" or less) into such systems. Board-board connectors carrying power and signals, and their position relative to the envelope are critical parameters in a product that has no cables to provide packaging leeway for the integrator.

In November 1992, the SFF Committee objectives were broadened to encompass other areas which needed similar attention, such as pinouts for interface applications, and form factor issues on larger disk drives. SFF is a forum for resolving industry issues that are either not addressed by the standards process or need an immediate solution.

Documents created by the SFF Committee are expected to be submitted to bodies such as EIA (Electronic Industries Association) or an ASC (Accredited Standards Committee). They may be accepted for separate standards, or incorporated into other standards activities.

The principles of operation for the SFF Committee are not unlike those of an accredited standards committee. There are 3 levels of participation:

- Attending the meetings is open to all, but taking part in discussions is limited to member companies, or those invited by member companies
- The minutes and copies of material which are discussed during meetings are distributed only to those who sign up to receive documentation.
- The individuals who represent member companies of the SFF Committee receive documentation and vote on issues that arise. Votes are not taken during meetings, only guidance on directions. All voting is by letter ballot, which ensures all members an equal opportunity to be heard.

Material presented at SFF Committee meetings becomes public domain. There are no restrictions on the open mailing of material presented at committee meetings. In order to reduce disagreements and misunderstandings, copies must be provided for all agenda items that are discussed. Copies of the material presented, or revisions if completed in time, are included in the documentation mailings.

The sites for SFF Committee meetings rotate based on which member companies volunteer to host the meetings. Meetings have typically been held during the ASC T10 weeks.

The funds received from the annual membership fees are placed in escrow, and are used to reimburse ENDL for the services to manage the SFF Committee.

If you are not receiving the documentation of SFF Committee activities or are interested in becoming a member, the following signup information is reprinted here for your information.

Membership includes voting privileges on SFF Specs under development.

CD\_Access Electronic documentation contains:

- Minutes for the year-to-date plus all of last year
- Email traffic for the year-to-date plus all of last year
- The current revision of all the SFF Specifications, as well as any previous revisions distributed during the current year.

Meeting documentation contains:

- Minutes for the current meeting cycle.
- Copies of Specifications revised during the current meeting cycle.

Each electronic mailing obsoletes the previous mailing of that year e.g. July replaces May. To build a complete set of archives of all SFF documentation, retain the last SFF CD\_Access mailing of each year.

Name: \_\_\_\_\_ Title: \_\_\_\_\_

Company: \_\_\_\_\_

Address: \_\_\_\_\_

\_\_\_\_\_

Phone: \_\_\_\_\_ Fax: \_\_\_\_\_

Email: \_\_\_\_\_

Please register me with the SFF Committee for one year.

- |  |                 |
|--|-----------------|
| ___ Voting Membership w/Electronic documentation   | \$ 2,160        |
| ___ Voting Membership w/Meeting documentation      | \$ 1,800        |
| ___ Non-voting Observer w/Electronic documentation | \$ 660 U.S.     |
|  | \$ 760 Overseas |
| ___ Non-voting Observer w/Meeting documentation    | \$ 300 U.S.     |
|  | \$ 400 Overseas |

Check Payable to SFF Committee for \$\_\_\_\_\_ is Enclosed

Please invoice me for \$\_\_\_\_\_ on PO #: \_\_\_\_\_

MC/Visa/AmX\_\_\_\_\_ Expires\_\_\_\_\_

SFF Committee  
14426 Black Walnut Ct  
Saratoga CA 95070

408-867-6630  
408-867-2115Fx  
endlcom@acm.org



**A cooperation agreement for a small form factor pluggable  
10 Gbit/s transceiver package**

**Revision  
2.2**

**December 5, 2002**

# Table of contents

1	List of tables . . . . .	3
2	List of figures . . . . .	4
3	Revision . . . . .	5
4	Summary of MSA group members . . . . .	5
5	Summary of MSA group sponsors . . . . .	6
6	Summary of MSA group contributors . . . . .	6
7	Purpose of this MSA . . . . .	8
8	Contribution to and distribution of this MSA . . . . .	8
9	Scope of this MSA . . . . .	8
10	Licensing, fees and IP policy . . . . .	9
11	Operating guidelines . . . . .	10
12	Sponsors and contributors . . . . .	10
13	Announcing and promoting the agreement . . . . .	11
14	Other vendors . . . . .	11
15	Future direction . . . . .	11
16	Limitation of liability . . . . .	11
17	Membership sign up form . . . . .	12
18	Mechanical specifications . . . . .	14
19	Thermal specifications . . . . .	27
20	Electrical specifications . . . . .	28
A1	Thermal testing environment . . . . .	31
A2	Flangeless module holder . . . . .	39

# 1 List of tables

Table 1: Datum definitions .....	16
Table 2: Module dimensions .....	16
Table 3: Host PCB and bezel opening dimensions .....	18
Table 4: Module holder dimensions .....	21
Table 5: Gasket dimensions .....	23
Table 6: Color coding .....	26
Table 7: XAUI pinout .....	28
Table 8: SFI4-P2 pinout .....	29
Table 9: Thermal test environment dimensions .....	32
Table 10: Thermal data table (at minimum airflow) .....	37



## 2 List of figures

Figure 1:	Isometric drawings	14
Figure 2:	Module	15
Figure 3:	Host PCB and bezel opening	17
Figure 4:	PCI card examples	18
Figure 5:	Tall and low profile module holders	20
Figure 6:	Bezel EMI gasket detail	23
Figure 7:	Isometric view of midboard mounted XPAK module.	23
Figure 8:	Midboard mounting module holder	24
Figure 9:	Midboard mounting host PCB	25
Figure 10:	Example PCI card with low profile XPAK module	25
Figure 11:	Module installation	27
Figure 12:	Module removal	27
Figure 13:	Test chamber cross-section	32
Figure 14:	Test chamber	33
Figure 15:	Airflow measurement points	34
Figure 16:	Front to Back Air Flow in Rack Enclosures	35
Figure 17:	Side to Side Air Flow in Rack Enclosures	35
Figure 18:	Air Flow on Switch/Server/cPCI Blades	36
Figure 19:	Air Flow on Horizontal & Vertical PCI Card Cards	36
Figure 20:	Air Flow in InfiniBand HCA/TCA Carriers	37
Figure 21:	Inlet air temperature vs. airflow	38
Figure 22:	Flangeless module holder host printed circuit layout	40
Figure 23:	Flangeless module holder	41

### 3 Revision

Rev	Date	By	Purpose/Changes
0.0	12 March 2002	David Kabal	First issue
0.1	15 March 2002	David Kabal	Changed charter members, reincorporated APS
0.2	22 March 2002	David Kabal	Minor mechanicals change
0.3	17 April 2002	David Kabal	Minor mechanicals, electricals by reference to XENPAK 2.1
0.4	5 May 2002	David Kabal	
0.5	10 May 2002	David Kabal	New latching holes, pins for alternate mounting, typo corrections
0.6	16 May 2002	David Kabal	Two versions introduced, low profile and tall profile, low profile version is angled.
0.7	22 May 2002	David Kabal	Minor corrections, preparing for publication.
1.0	24 May 2002	David Kabal	Renumbered 0.7
1.1	7-18 June 2002	David Kabal, Jay Neer	Added midboard mounting, thermal environment, separated out sections
1.2	9-12 July 2002	David Kabal, Jay Neer	Rail changed to a set of pins throughout, height of "tall" module increased, operating guidelines clarified (re: voting rules), more representative figures added to thermal environment section, added bail latch mechanism, added "contributor" to class of member.
1.99	25 July 2002	XPAK group	Live edit during XPAK face-to-face
2.0	5 August 2002	David Kabal	Added flangeless module holder, minor corrections and cleanups..
2.1	30 August 2002	David Kabal	Changed some terminology, added pinouts, new OUI, new members
2.2	24 Nov 2002	David Kabal	Added extended low profile verison, new members, reduced excess dimensions not in use

### 4 Summary of MSA group members

Company	Representative	Contact info
Blaze Network Products	Todd Whitaker	twhitaker@blazenp.com
E2O	Kee Sin Tan	kstan@e2oinc.com
Fujitsu Quantum Devices	Hyunglim (Dean) Ji	hji@fcsi.fujitsu.com
Kodeos Communications	Jason Stark	j.stark@kodeos.com
Infineon	Rami Kanama	rami.kanama@infineon.com
Intel	Robert Zona	robert.zona@intel.com
Molex	Jay Neer	jneer@molex.com
Network Elements	Raj Savara	rsavara@networkelements.com
Optium	Pete Hallemeier	phallemeier@optiumcorp.com
Picolight	David Kabal	david.kabal@picolight.com
Pine Photonics	Osa Mok	omok@pinephotonics.com
RedClover Networks	Genzao Zhang	gzhang@redclovernetworks.com
Tyco Electronics	Bob Atkinson	rdatkins@tycoelectronics.com

## 5 Summary of MSA group sponsors

Company	Representative	Contact info
Intel	Bradley Booth	bradley.booth@intel.com
IXIA		
JNI	Mark Woithe	mwoithe@jni.com
McData	John Burns	john.burns@mcddata.com
QLogic	Greg Casey	greg.casey@qlogic.com
Spirent Communications	Rick Rabinovich	rick.rabinovich@spirentcom.com

## 6 Summary of MSA group contributors

Company	Representative	Contact info
4WAVE	David Baldwin	
AMO	Jurgen Martini	
BitBlitz	Glen Young	
Broadcom	Kory Sefidvash	kory@broadcom.com
Fourte Design and Development	Scott Herbert	scott@fourtedd.com
OEPIIC	M. Leonard Riazat	mriazat@oepic.com
PHYWORKS	Nick Weiner	
ITRI	Min Sheng Kao	michael_doraemon@itri.org.tw
Quake Technologies	Justin Chang	justin@quaketechnology.com



# **Membership agreement**

## 7 Purpose of this MSA

7.1 The contributing companies desire to establish internationally compatible sources of pluggable transceiver modules in support of the various specifications, including approved implementations of IEEE 10 Gigabit Ethernet Standard, T11 10 Gigabit Fibre Channel, OIF OC192 VSR Implementation Agreements, ANSI SONET, ITU SDH and InfiniBand:

These 10 Gbit/s module implementations are grouped into two categories for the purpose of this MSA:

- **XAUI** implementations use the four lane 10 Gigabit Attachment Unit Interface (XAUI) electrical interface to electrical connect to the module. XAUI implementations are designed to either work at the IEEE 10GBASE-R optical rate of 10.3125 Gbit/s with a four lane electrical interface at 3.125 Gbit/s or at the 10 Gigabit Fibre Channel optical rate of 10.51875 Gbit/s with a four lane electrical interface at 3.1875 Gbit/s.
- **SFI4-P2** implementations (compliant to OIF2002.166) use the clocked four lane OIF SFI4-Phase 2 electrical interface for OC-192, digital wrapper and FEC (Forward Error Correction) interfaces operating at a data rate of 9.95 Gbit/s to 11.2 Gbit/s.

7.2 Each party desires to establish uniformity in the areas described in the Section, "Scope of this MSA".

7.3 Each party expects that the establishment of multiple compatible sources of small form factor 4-lane electrical interface pluggable 10 Gigabit modules will allow the entire marketplace to grow more rapidly. This enhanced marketplace growth, customer choice, and vigorous competition are the express purposes of this Agreement.

## 8 Contribution to and distribution of this MSA

8.1 The charter members of this MSA are Infineon, Intel and Picolight.

8.2 The final MSA document shall be made available to all Participating Members and to non-participants who request a copy, after the document is signed and complete.

## 9 Scope of this MSA

9.1 The parties agree to cooperate by supporting common product specifications for pluggable transceivers with the package and functionality specified in Section 18, Section 19 and Section 20. The overall package dimensions shall conform to the indicated dimensions and tolerances, and the mounting features shall be located such that the products are mechanically interchangeable with the module holder and connector system. In addition the overall dimensions and mounting requirements for the module holder and connector system on a circuit board shall be configured such that the products are mechanically and electrically interchangeable.

9.2 Each party acknowledges this agreement provides a common solution for PMDs for multiple specifications but may not provide an optimum solution for applications with different constraints.

9.3 The electrical and optical specifications shall be compatible with those enumerated in the appropriate standards (i.e. the IEEE 802.3ae 10 Gigabit Ethernet standard). Recommended circuit layouts for electrical input and output terminations, and grounding practices are also described in the Appendix of this MSA.

9.4 The specific PMD implementation and internal design of the module is entirely at the discretion of each party and is not covered by this Agreement. The parties recognize that their products may not be identical, but need only meet the criteria shown in the Appendix of this MSA to assure interchangeability.

9.5 This agreement relates to transceivers with transmission rates up to 11.2 Gbit/s, operating over multimode fiber, single mode fiber and copper.

## 10 Licensing, fees and IP policy

10.1 No license is granted under the patents, know-how, trade secrets or any other technology of any party to this Agreement either expressly or by implication or by estoppel.

10.2 Each of the MSA parties has agreed that licenses to all intellectual property necessary to realize a module conforming to this MSA will be made available to all interested parties. These licenses will be granted under reasonable and non-discriminatory terms and conditions applicable to that MSA party, conditional on the interested party also agreeing to license any necessary intellectual property to the parties of this MSA.

10.3 Members who hold patents (U.S. or foreign) that have been granted or are under application and who feel that such patents cover technology described in the MSA are required to submit a letter which will be kept on file on the private XPAK website. This letter must assure that any granted patent will follow the XPAK IP policy:

- a) A general disclaimer to the effect that the patentee will not enforce any of its present or future patent(s) whose use would be required to implement the proposed XPAK MSA against any person or entity using the patent(s) to comply with the MSA or
- b) A statement that a license will be made available to all applicants without compensation or under reasonable rates, with reasonable terms and conditions that are demonstrably free of any unfair discrimination.

The submitter should feel free to include any other information that they wish to communicate in such a letter that will be available on a long term basis.

The letter should be addressed and submitted to the XPAK MSA via the e-mail reflector or to XPAK MSA c/o Picolight, Inc, and signed by a responsible party that holds or will hold assignment rights to the patent.

10.4 Each party agrees to be responsible for its own development, manufacturing, marketing and selling in order to supply transceivers meeting the attached specifications.

10.5 This Agreement does not preclude any party from offering other products that may not meet the attached specifications.

10.6 Each party retains complete liberty regarding its methods of implementing a supply of product, e.g., by engineering effort or by technology licensing or transfer or combination of these or other practices.

10.7 Each party also retains sole discretion in its choice of sales channels and distribution.

10.8 Each party affirms its intention to compete freely and openly in the marketplace with the parties as well as other competitors. Each party expects to support products meeting the attached specifications for as long as marketplace conditions warrant. No specific time limit is associated with this Agreement. The determination of market condition suitability is to be made by each party individually and in each party's sole discretion.

## 11 Operating guidelines

11.1 Any new action item, design change, membership action, decision on public information disclosure, or other activity related to this MSA or its Guidelines will require the approval of a minimum of 75% of the voting members. Members abstaining from voting are not to be considered in this percentage. No response will be interpreted as an abstention. Each participating company will have one vote.

11.2 Each participating company must identify the person(s) in their organization that have the authority and responsibility to sign the final MSA. At least one such person, or delegate with full authority to represent the Company, must participate in each meeting and will have the single vote for that Company. If a Company fails to attend a MSA meeting twice in succession, they will be subject to a vote of removal from the MSA.

11.3 If a non-represented Optical Transceiver Company asks to join the MSA, they may join the discussions if they are willing to agree to the operating guidelines and accept the current MSA specifications in their entirety. New members will not be allowed to revisit work already established, or to make motions or vote to change existing designs, parameters, or characteristics. Additionally, approval of at least 75% of the voting members will be required to admit new members.

11.4 There will be no permanent Chairperson for this group, though the position can be created by approval of at least 75% of the voting members.

11.5 Each Participating Company's representatives will treat the Substance of the MSA Discussions as confidential until such time as it is agreed by the participants to make a simultaneous Public disclosure. If the participant group agrees to discuss specific MSA details with the market before making a decision, this may be done with a 75% majority vote. It is acceptable to tell the market that discussions to achieve an MSA are underway without mentioning timing, content, number or names of participants, or possible outcomes of the discussions.

11.6 Companies may be removed from the MSA group by vote of a minimum of 75% of the voting members. Members abstaining from voting are not to be considered in this percentage. The vote will decide whether loss of voting rights or removal from the group will be imposed.

## 12 Sponsors and contributors

12.1 Sponsoring Members (Sponsors) will be equipment manufacturers or service providers in the networking communications industry. Sponsors represent typical customers for XPAK modules.

12.2 Contributors will be companies interested in providing design input to the MSA who are not considered Sponsors or Participating Members.

12.3 Sponsors will be recruited to provide design input and validation of the work created by the MSA.

12.4 Sponsors and contributors will:

- Have full access to all specifications of this MSA and meeting minutes.
- Be admitted to all meetings or teleconferences called by the MSA group. Such admission may be limited to 1 representative per company to allow for manageable and focused meetings.
- Will be encouraged to provide recommendations to add features or functions, to clarify the operation of devices described by this document, or to otherwise suggest modifications to this document.
- Not participate in voting to modify this MSA or its Guidelines.
- Be admitted or removed from the MSA by action of the Group.

## 13 Announcing and promoting the agreement

13.1 This MSA and the form factor that it describes will be known as “XPAK”.

Examples of how this term would be used include (but are not limited to):

The “XPAK MSA group”

The “XPAK form factor”

13.2 Each party agrees to announce this Agreement in a manner agreed upon by the parties, such announcements will mention all the parties who have signed this Agreement.

13.3 Each party agrees to seek public attention by means of such an announcement.

13.4 Each party agrees to use the XPAK name in reference to this MSA in announcements and promotional efforts.

13.5 Each party agrees to use any “image” guidelines agreed by the group when referring to the XPAK MSA such as logos or other identity elements that have been defined by the group.

13.6 After the Agreement is announced, each party may advertise or otherwise promote this Agreement in any way that it deems appropriate. Other parties to this agreement can be mentioned by name when used to discuss the activities of this group without the other party’s prior consent.

## 14 Other vendors

14.1 The parties recognize that additional vendors may choose to match the attached product specifications after this Agreement is announced.

14.2 Each party recognizes it is desirable and keeping with the intent of the Agreement for such additional vendors to support the transceiver mechanical dimensions and functional attributes described in this specification. Therefore, each party agrees to encourage other vendors to support these product specifications, after this Agreement is announced.

## 15 Future direction

15.1 *Current Product:* Should the parties agree to further explore technical and other exchanges pertaining to the products described in this Agreement, then this shall be under a separate agreement.

15.2 *Withdrawal:* The parties recognize that at some future time it may become less feasible to offer the products envisioned by this Agreement. A party may withdraw from its commitment to cooperate at its own discretion upon a 90-day notice to the other parties.

## 16 Limitation of liability

16.1 With the exception of disputes arising out of intellectual property issues, no party to this Agreement shall be liable for any indirect, incidental, punitive, or consequential damages, including without limitation, lost profits or changes of good will, or similar losses, even if advised of the possibility of such damages. In addition, each party’s liability under this Agreement for direct damages shall be limited to \$10,000 (ten thousand United States dollars).



## 17 Membership sign up form

On behalf of [Company Name]:

---

Address:

---

---

Membership category:  
(Check One)

- Participating member  
 Sponsor  
 Contributor

We agree to the terms and conditions of the XPAK MSA guidelines as described in Section 7 through Section 16, and request membership to the MSA group.

**by:**  
**(company signing authority)**

---

Signed

---

Name

---

Title

---

Date

**Designated contact:**  
**(XPAK MSA representative)**

---

Name

---

e-mail address

---

phone number



# Specifications

## 18 Mechanical specifications

### 18.1 Introduction

The mechanical specifications for the XPAK MSA define three versions of the module holder and of the module itself. These are not intended to be interoperable. The “tall profile” is to be used where enhanced thermal performance is required, such as in a dense, multiple module situation under non-ideal airflow and higher inlet temperature. The “low profile” is PCI-compliant. The midboard mounting module holder can accommodate various height modules where faceplate pluggability is not required. The drawings in Figure 1 show the volumetric envelope of these versions, but is not intended to represent an actual implementation, where the increased volume defined by the tall profile may be used for added thermal features or for increased interior volume.

**Figure 1: Isometric drawings**

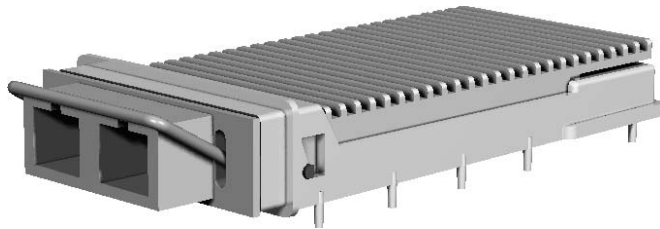

**Low profile**

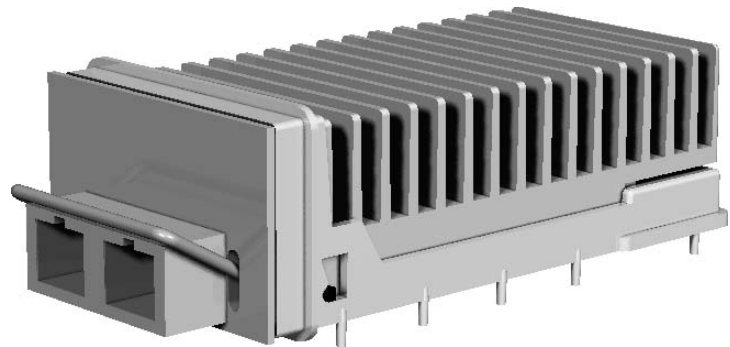

**Tall profile**

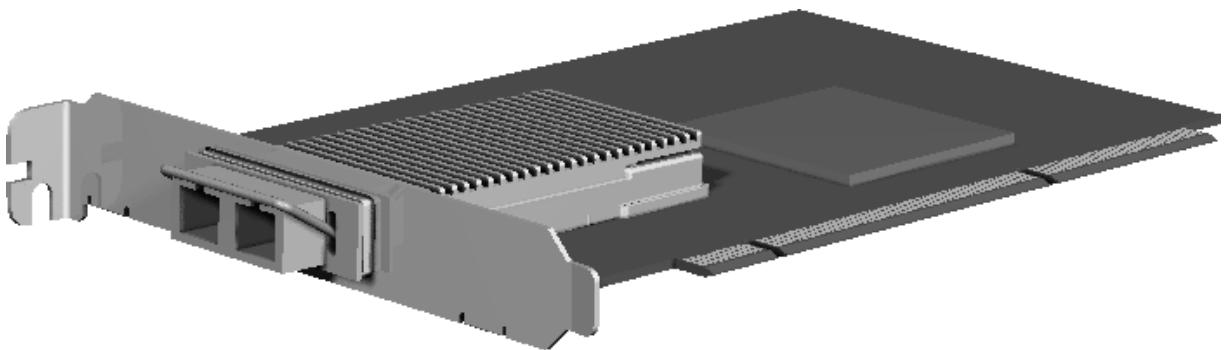

**Low profile version on PCI card (example application)**

Figure 2: Module

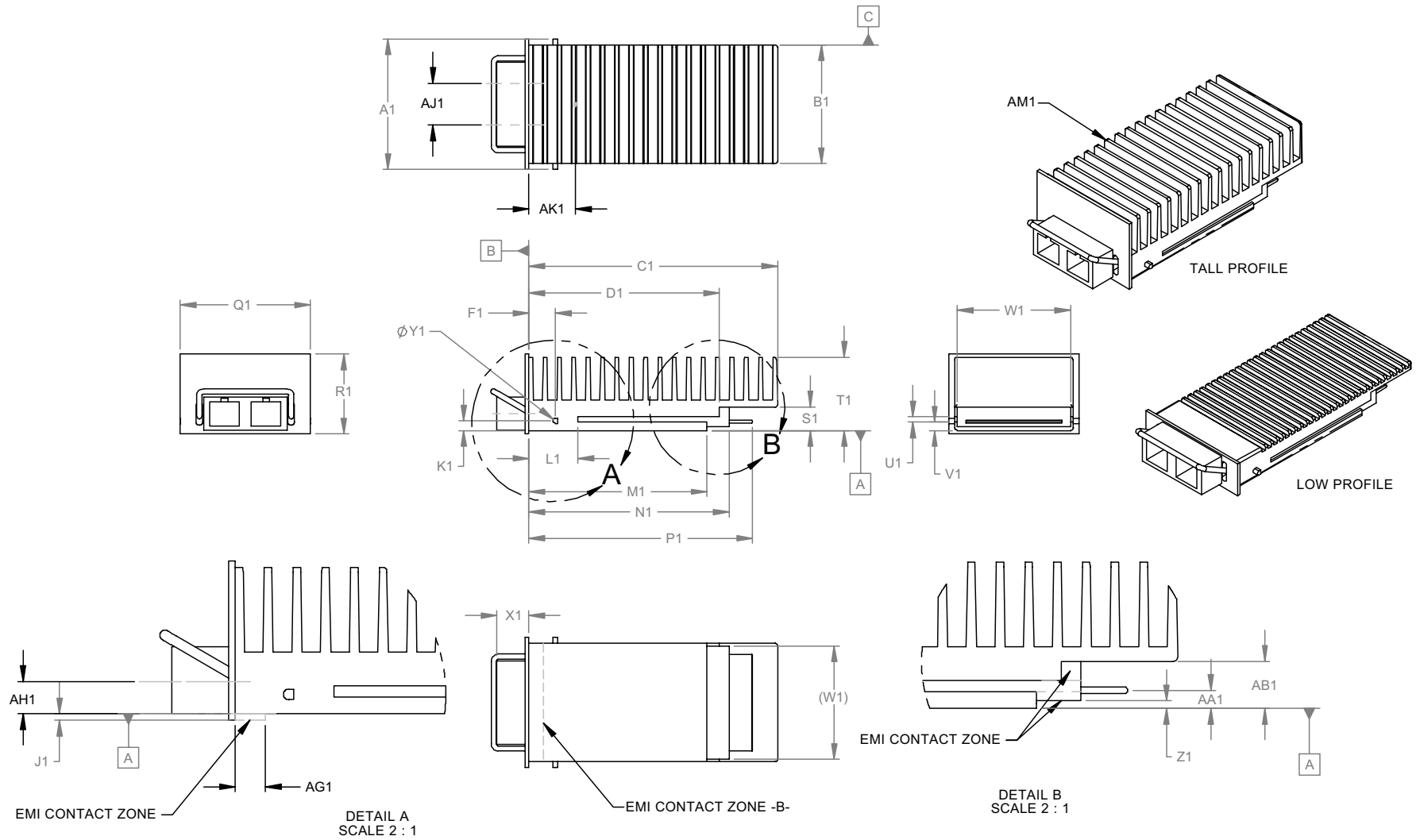

**Table 1 Datum definitions**

Datum	Comments
A	Module bottom surface
B	Back surface of module gasket flange
C	Module width
D	Module holder bottom surface touching host PWA. Tall profile only (coincident with host PWA datum –G- Tall profile only) Low profile module holder references same plane as tall profile from which bottom surface touching host PWA is defined.
E	Module holder front surface
F	Module holder interior width
G	Top surface of host PWA (coincident with module holder datum –D-)
H	Hole in PWA for guide pin
I	Not used
J	Hole in PWA for guide pin

**Table 2 Module dimensions**

Item	Dimensions		Tolerances +/-		Comments
	MM	[IN]	MM	[IN]	
A1	39.62	1.560			Max width of latch features
B1	35.99	1.417	.12	.005	Width of module
C1	75.69	2.980			Max length of module from faceplate
D1	57.96	2.282			Max length to end of module step
E1	.76	.030			Min edge radius
F1	8.13	.320	Basic	Basic	Centerline of latch feature from faceplate
G1					Optical axis from Datum -A-
H1					Optical axis
I1					Not Used
J1	1.02	.040	.12	.005	Faceplate to bottom surface of module
K1	2.92	.115	Basic	Basic	Centerline of latch feature to bottom of module
L1	14.99	.590			Max distance to end of module holder slot
M1	54.23	2.135	.12	.005	Faceplate to module step
N1	60.96	2.400	.12	.005	Faceplate to module step
O1					Not Used
P1	68.07	2.680	.12	.005	Faceplate to end of PWA
Q1	39.55	1.557			Max width of faceplate
R1	24.28	.956			Max height of faceplate (Tall profile)
	11.84	.466			Max height of faceplate (Low profile)
S1	9.91	.390			Min distance to bottom of thermal solution zone (Tall profile)
T1	22.25	.876	.12	.005	Height of module (Tall profile)
	9.80	.386	.12	.005	Height of module (Low profile)
U1	1.65	.065	.12	.005	Height of alignment guide pin slot
V1	2.56	.101	.12	.005	Bottom edge of alignment guide pin slot to bottom of module
W1	34.42	1.355	.12	.005	Width between alignment guide pin slots
X1	9.65	.380			Max length of connector from faceplate
Y1	1.52	.060	.12	.005	Diameter of latch feature front face
Z1	1.14	.045	.12	.005	Min bottom of module to first step
AA1	2.72	.107	.12	.005	Bottom of module to C/L of PWA
AB1	7.14	.281			Min bottom of module to bottom of connector shroud

**Table 2 Module dimensions (Continued)**

Item	Dimensions		Tolerances +/-		Comments
	MM	[IN]	MM	[IN]	
AC1					Location of thermocouple (thermal testing) (Test point should be at base of heat dissipation feature)
AD1	4.57	.180			Max EMI contact zone (optional)

**Figure 3: Host PCB and bezel opening**

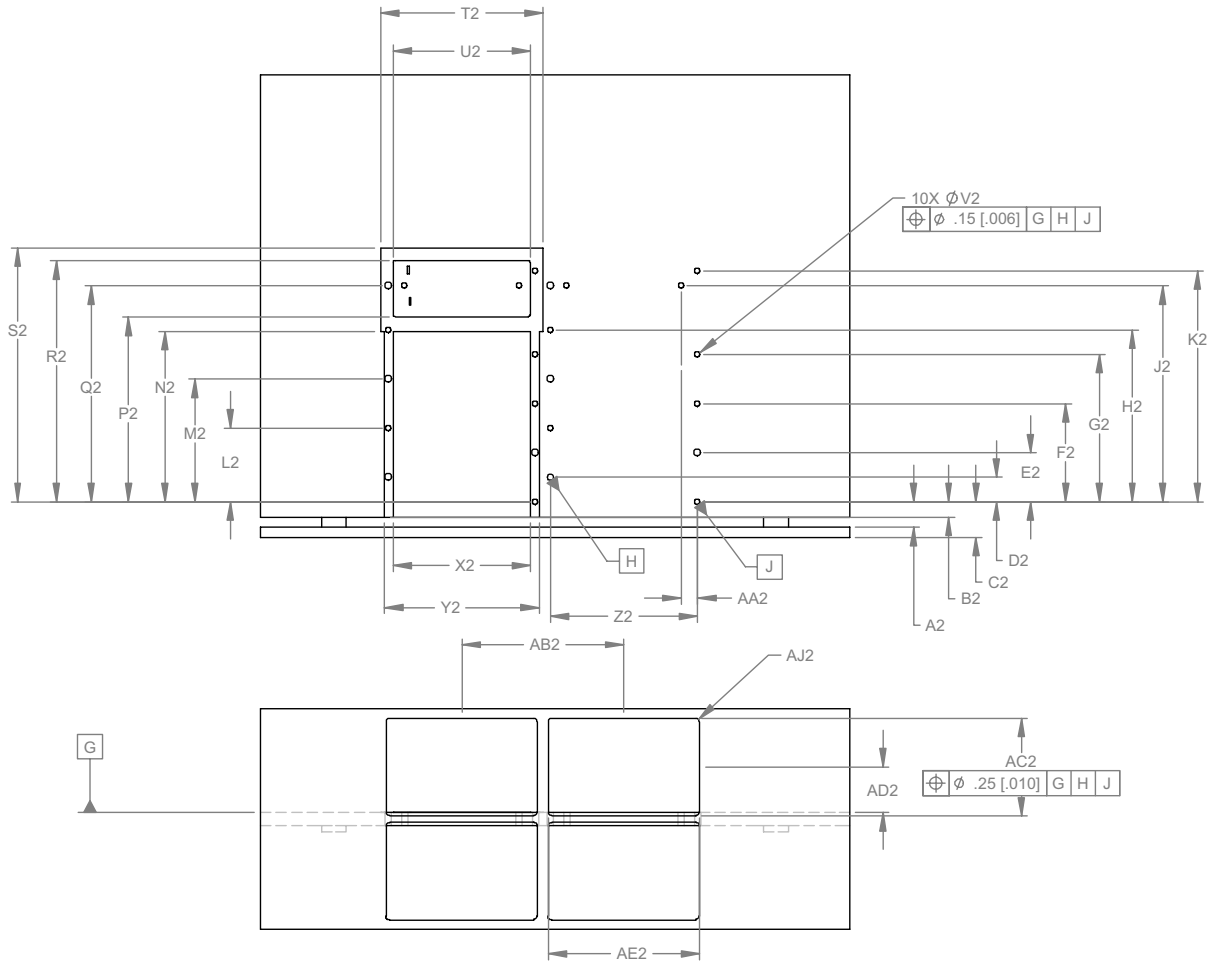

**Figure 4: PCI card examples**

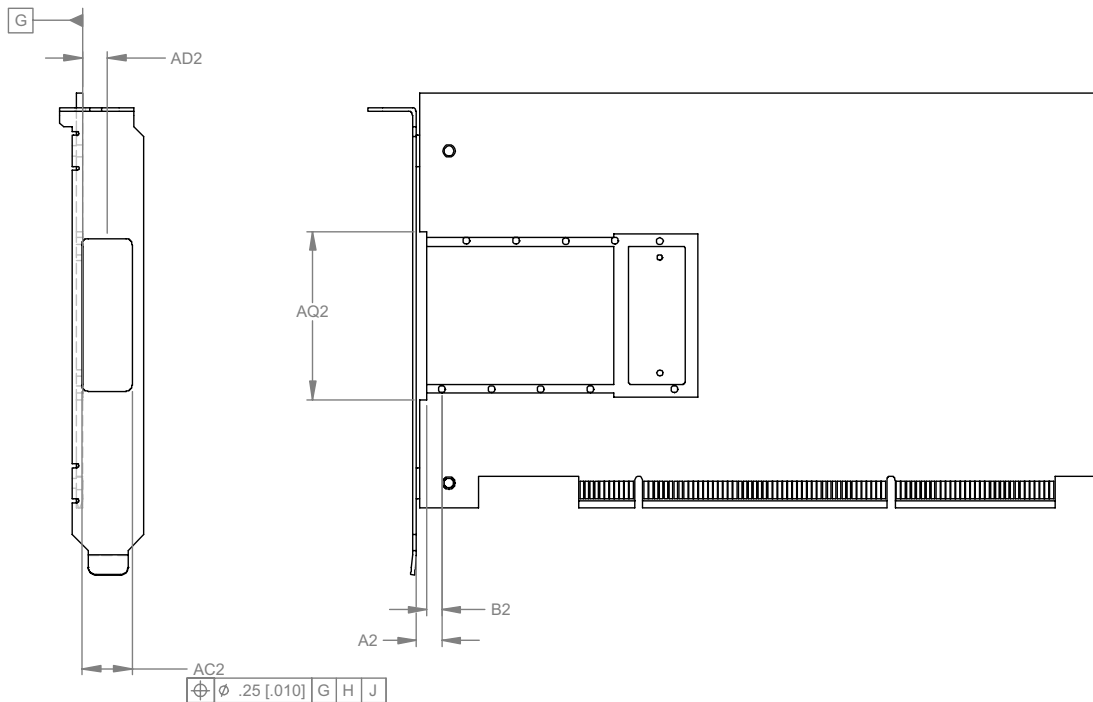

**Table 3 Host PCB and bezel opening dimensions**

Item	Dimensions		Tolerances +/-		Comments
	MM	[IN]	MM	[IN]	
A2	6.60	.260	.38	.015	Guide pin to panel back face (Tall and low profile)
	7.39	.291	.38	.015	Guide pin to panel back face (Flangeless)
B2	3.94	.155	Basic	Basic	Guide pin location (Tall and low profile)
C2	9.14	.360			Max to panel front face (Tall and low profile)
D2	6.35	.250	Basic	Basic	Guide pin location
E2	12.7	.500	Basic	Basic	Guide pin location
F2	25.4	1.000	Basic	Basic	Guide pin location
G2	38.10	1.500	Basic	Basic	Guide pin location
H2	44.45	1.750	Basic	Basic	Guide pin location
I2					Not used
J2	55.88	2.200	Basic	Basic	Connector pin location
K2	59.69	2.350	Basic	Basic	Guide pin location
L2	19.05	.750	Basic	Basic	Guide pin location
M2	31.75	1.250	Basic	Basic	Guide pin location
N2	44.07	1.735			Max front edge of ground pad
O2					Not used
P2	47.80	1.882			Min back edge of ground pad
Q2	55.88	2.200	Basic	Basic	Guide pin location
R2	62.36	2.455			Max front edge of ground pad
S2	65.66	2.585			Min back edge of ground pad
T2	41.91	1.650			Min outside edges of ground pad
U2	35.51	1.398			Max inside edges of ground pad
V2	1.58	.062	.08	.003	Pin hole diameter
X2	35.51	1.398			Max inside edges of ground pad
Y2	40.03	1.576			Min outside edges of ground pad

**Table 3 Host PCB and bezel opening dimensions (Continued)**

Item	Dimensions		Tolerances +/-		Comments
	MM	[IN]	MM	[IN]	
Z2	38.10	1.500	Basic	Basic	Guide pin location
AA2	4.24	.167	Basic	Basic	Connector pin location
AB2	41.91	1.650			Min pitch between module holders
AC2	25.30	.996	.12	.005	Height of panel opening (Tall profile)
	12.85	.506	.12	.005	Height of panel opening (Low profile)
	10.31	.406	.12	.005	Height of panel opening (Flangeless)
AD2	11.76	.463	Basic	Basic	Vertical position of panel opening C/L (Tall profile)
	6.40	.252	Basic	Basic	Vertical position of panel opening C/L (Low profile)
	6.43	.253	Basic	Basic	Vertical position of panel opening C/L (Flangeless)
AE2	39.12	1.540	.12	.005	Width of panel opening (Tall and low profile)
	36.50	1.437	.12	.005	Width of panel opening (Flangeless)
AF2	6.35	.250			Max back edge of ground pad (Midboard)
AG2	3.81	.150			Min front edge ground pad (Midboard)
AH2	25.35	.998			Min keep out for module removal (Midboard)
AJ2	1.02	.040			Max corner radius (Tall and low profile)
	.51	.020			Max corner radius (Flangeless)
AK2	11.99	.472	.12	.005	Height of faceplate recess (Flangeless)
AL2	38.15	1.502	.12	.005	Width of faceplate recess (Flangeless)
AM2	.51	.020			Max corner radius for faceplate recess (Flangeless)
AN2	2.03	.080	.12	.005	Faceplate thickness (Flangeless)
AO2					Not used
AP2	1.02	.040	.12	.005	Depth of recess (Flangeless)



**Figure 5: Tall and low profile module holders**

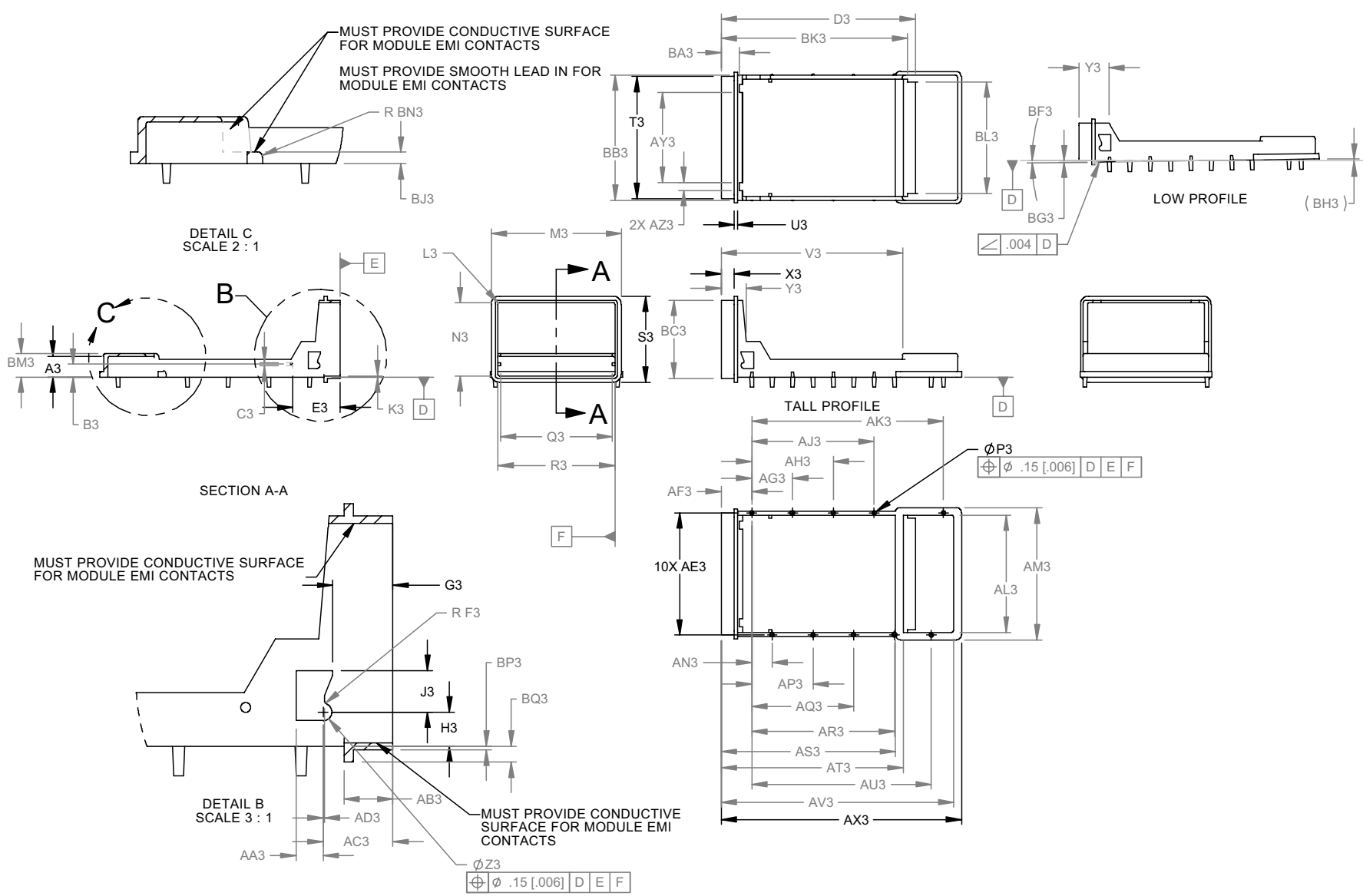

**Table 4 Module holder dimensions**

Item	Dimensions		Tolerances +/-		Comments
	MM	[IN]	MM	[IN]	
A3	6.50	.256	.12	.005	Datum –D- to interior height of connector cover
B3	4.01	.158	.12	.005	Datum –D- to centerline of module holder alignment features
C3	1.02	.040	.12	.005	Diameter of module holder alignment features
D3	60.48	2.381			Front face of module holder to connector cover
E3	15.24	.600	.25	.010	Front face to front edge of module holder alignment feature
	46.99	1.850	.25	.010	Front face to front edge of module holder alignment feature (Midboard mount)
F3	.51	.020	.25	.010	Radius of detent
G3	6.22	.245			Max top of latch cutout to front face of module holder
H3	3.56	.140	Basic	Basic	C/L of latch cutout to Datum –D-
I3					Not Used
J3	4.32	.170			Min C/L of latch cutout to height of latch cutout
K3	.38	.015	.12	.005	Datum –D- to lower internal face of module holder
L3	.51	.020			Max interior corner radius
M3	40.56	1.597			Max width of flange (Tall and low profile)
N3	22.76	.896	.12	.005	Interior height of module opening (Tall profile)
	10.31	.406			Interior height of module opening (Low profile)
O3					Not Used
P3	1.14	.045	.05	.002	Diameter of pin
Q3	34.72	1.367	.12	.005	Width between module holder alignment features
R3	36.50	1.437	.12	.005	Interior width of module opening
S3	26.82	1.056	.12	.005	Height of flange (Tall profile)
	14.38	.566			Height of flange (Low profile)
T3	38.02	1.497	.12	.005	Exterior width of module opening (Tall, low and midboard)
	37.77	1.487	.12	.005	Exterior width of module opening (Flangeless)
U3	1.02	.040	.12	.005	Thickness of flange (Tall and low profile)
V3	56.49	2.224	.12	.005	Front face to connector cover side wall step
X3	4.06	.160	.12	.005	Front face of module holder to front face of flange (Tall and low profile)
Y3	7.72	.304			Max front face of module holder to front of thermal solution opening (tall profile)
	9.40	.370			Max front face of module holder to front of thermal solution opening (low profile)
Z3	1.78	.070	.12	.005	Diameter of latch cutout
AA3	2.79	.110			Min bottom width of latch cutout
AB3	5.08	.200			Max front face to cut out for host PWA
AC3	7.24	.285	Basic	Basic	Front face of module holder to C/L of bottom of latch cutout
AD3	.12	.005	.12	.005	Tangent edge of F3 from C/L of bottom latch cutout
AE3	38.10	1.500	Basic	Basic	Guide pin location
AF3	9.52	.375	Basic	Basic	Front face of module holder to pin location
AG3	12.7	.500	Basic	Basic	Guide pin location (optional)
AH3	25.4	1.000	Basic	Basic	Guide pin location (optional)
AI3					Not used
AJ3	38.1	1.500	Basic	Basic	Guide pin location
AK3	59.69	2.350	Basic	Basic	Guide pin location (optional)
AL3	36.50	1.437			Min inside width of connector flange
AM3	41.07	1.617			Max overall width of connector flange
AN3	6.35	.250	Basic	Basic	Guide pin location

**Table 4 Module holder dimensions (Continued)**

Item	Dimensions		Tolerances +/-		Comments
	MM	[IN]	MM	[IN]	
AO3					Not used
AP3	19.05	.750	Basic	Basic	Guide pin location (optional)
AQ3	31.75	1.250	Basic	Basic	Guide pin location (optional)
AR3	44.45	1.750	Basic	Basic	Guide pin location
AS3	54.28	2.137			Min front face of module holder to front edge of connector flange
AT3	56.67	2.231			Max front face of module holder to back edge of connector flange
AU3	55.88	2.200	Basic	Basic	Guide pin location (optional)
AV3	72.39	2.850			Min front face of module holder to inside edge of connector flange
AX3	74.83	2.946			Max overall length of module holder
AY3	27.94	1.100	.12	.005	Distance between latch cutouts on top surface
AZ3	2.54	.100			Min width of latch cutout on top surface
BA3	5.59	.220	.12	.005	Front face of module holder to front edge of latch cutout on top surface
BB3	39.04	1.537	.25	.010	Width of module holder
BC3	24.28	.956	.25	.010	Exterior height of module opening (Tall profile)
	11.84	.466	.25	.010	Exterior height of module opening (Low profile)
	11.56	.455	.25	.010	Exterior height of module opening (Flangeless)
BD3	2.97	.117	.12	.005	Depth for T3 and BC3 (flangeless)
BE3	.25	.010	.05	.002	Bottom surface of BC3 from Datum -D- (flangeless)
BF3		.8°	Basic	Basic	Slope of bottom edge from datum -D- (Low profile only)
BG3	.81	.032	Basic	Basic	Front vertex of .8° from datum -D- (Low profile only)
BH3	.18	.007			Ref back vertex of .8° from datum -D- Based on max length (Low profile only)
BI3					Not used
BJ3	1.78	.070	.12	.005	Height of rib from datum -D-
BK3	58.01	2.284			Front face of module holder to front edge of connector cover step
BL3	34.72	1.367			Width between connector cover side steps
BM3	7.26	.286	.12	.005	Height of connector cover from Datum -D-
BN3	.76	.03			Min radius on cross bar
BO3					Not used
BP3	.38	.015	.05	.002	Datum -D- to bottom exterior edge of module opening
BQ3	1.65	.065	.05	.002	Datum -D- to bottom of flange
BR3	1.73	.068	.12	.005	Module Holder face cut back from Datum -E- (Flangeless)

**Figure 6: Bezel EMI gasket detail**

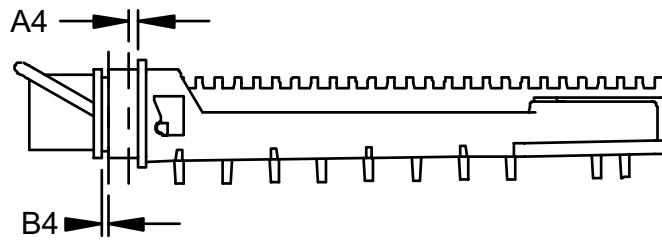

**Table 5 Gasket dimensions**

Item	Dimensions		Tolerances +/-		Comments
	MM	[IN]	MM	[IN]	
A4	1.27	.050	.38	.015	Module Holder to backside of faceplate gasket compression
B4	.89	.035	.12	.005	Module to module holder gasket compression

## 18.2 Midboard mounting

The following section defines an optional module holder allowing an XPAK module (either tall or low profile) to be mounted on the interior of a board. The midboard mounting module holder specified here does not preclude a taller module than specified by the XPAK tall module.

**Figure 7: Isometric view of midboard mounted XPAK module.**

low profile version shown

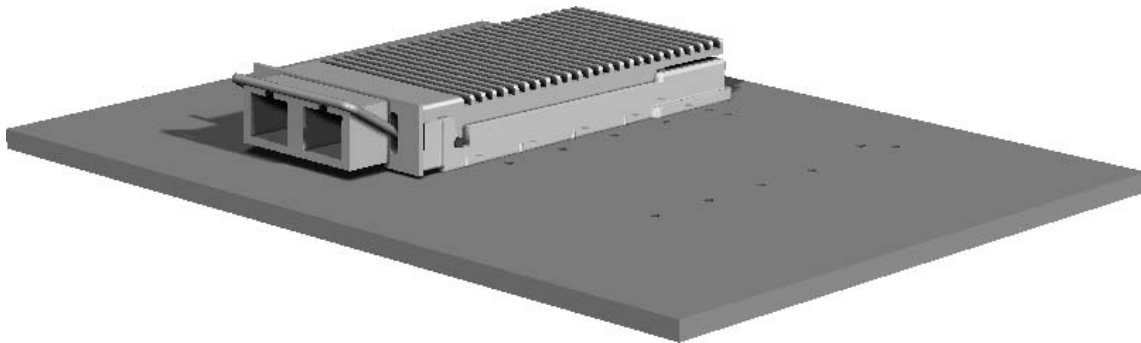

**Figure 8: Midboard mounting module holder**

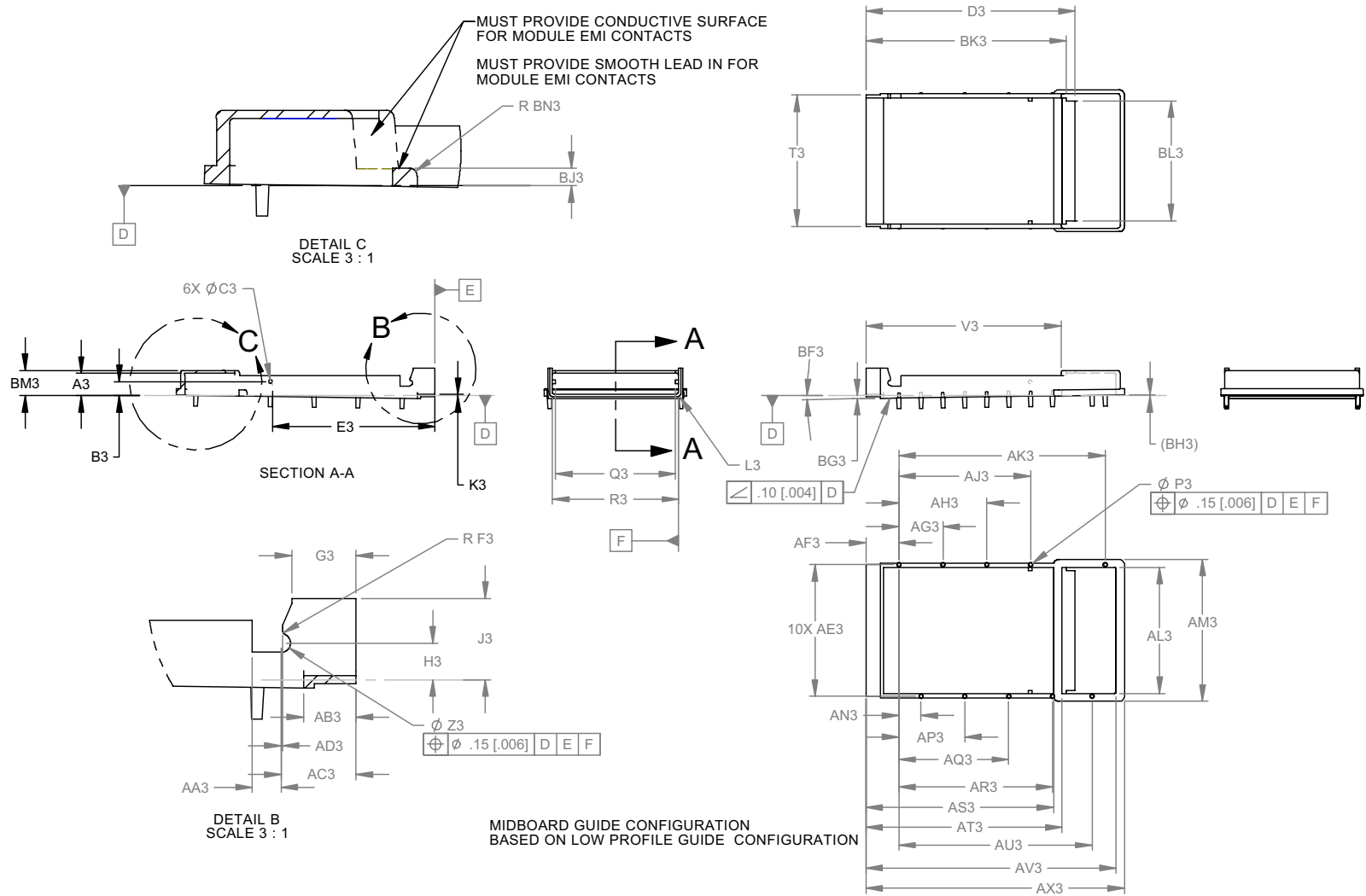

**Figure 9: Midboard mounting host PCB**

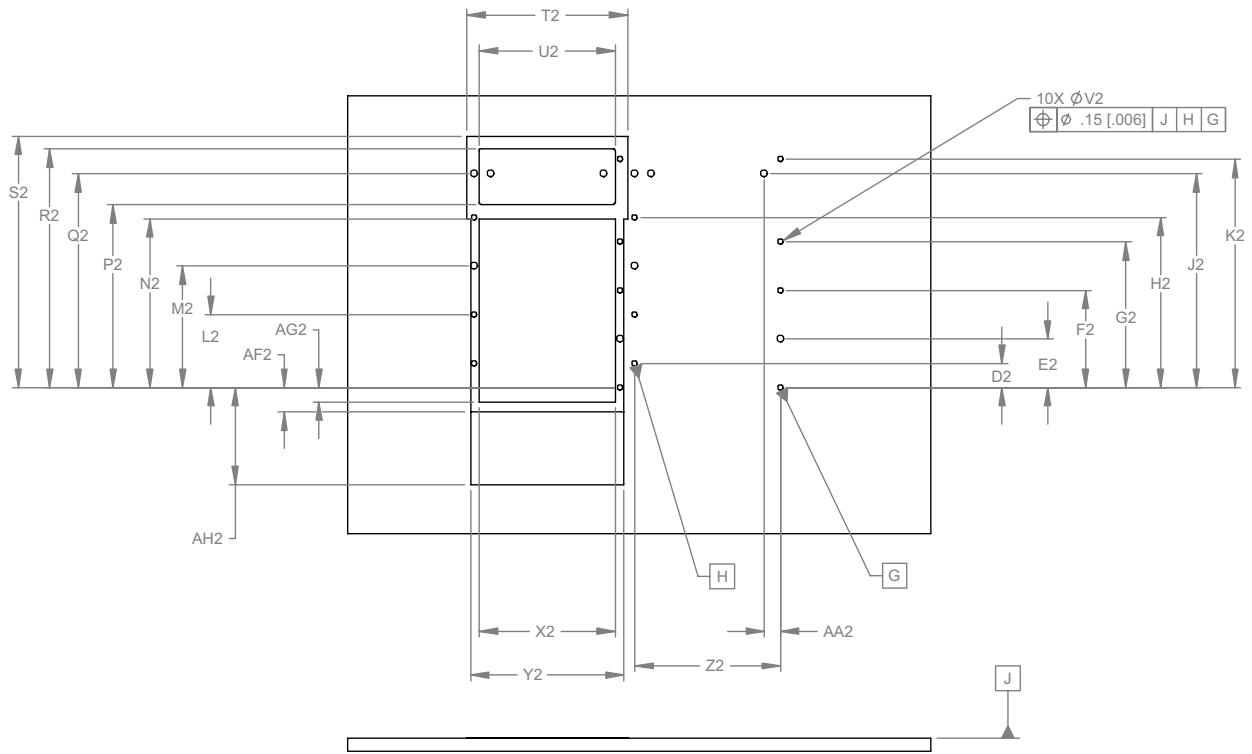

**18.2.1 Midboard mounting module holder dimensions**

Dimensions and datums for Figure 8 and Figure 9 are listed in Table 1 on page 16, Table 2 on page 16, Table 3 on page 18 and Table 4 on page 21.

**Figure 10: Example PCI card with low profile XPAK module**

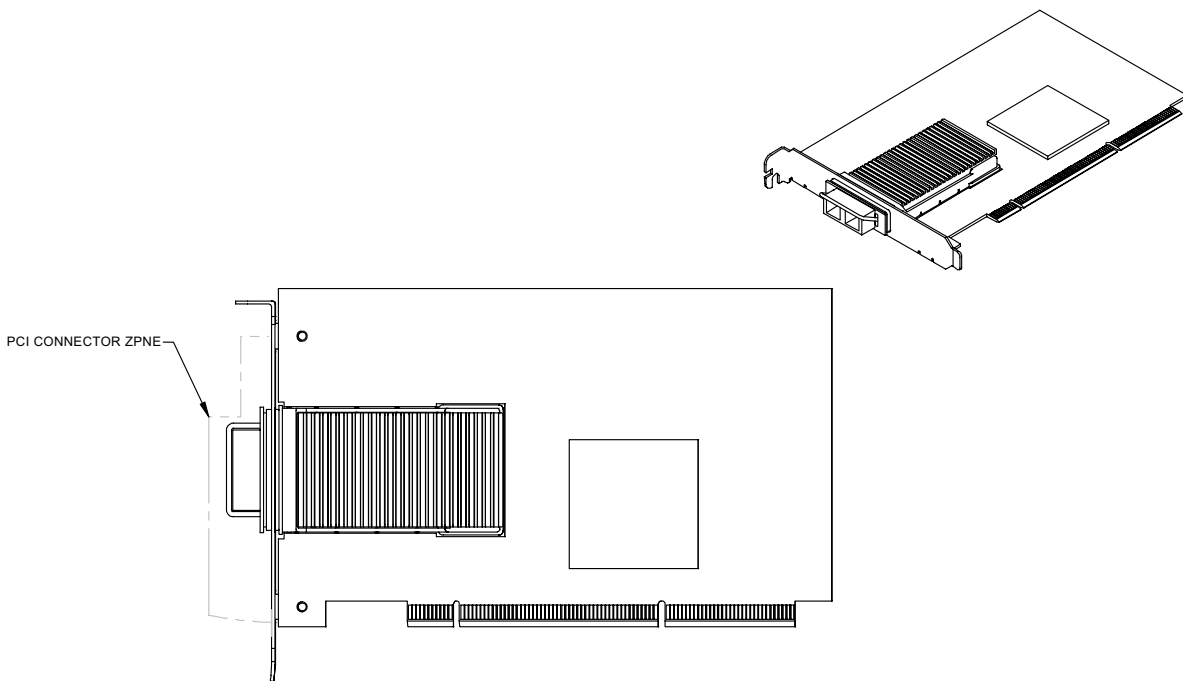

### 18.3 Transceiver printed circuit board

A typical contact pad plating for the printed circuit board is 0.38 micrometers minimum hard gold over 1.27 micrometers minimum thick nickel. Other plating options that meet the performance requirements are acceptable.

### 18.4 Host board mechanical layout

See Figure 3 on page 17. For belly-to-belly applications, a board thickness of at least 0.135" is required.

### 18.5 Color coding

Modules shall be color coded at a location visible outside the bezel when the XPAK module is fully inserted and latched as defined below:

**Table 6 Color coding**

PMD	Color coding
10GBASE-SR	Beige
10GBASE-LR	Blue
10GBASE-ER	Green
10GBASE-LX4	Gold
Copper	Not defined
Other	Not defined

### 18.6 Optical interface

The objective of this section is to specify the optical connector interface to sufficiently ensure performance, intermateability and maximum supplier flexibility.

#### 18.6.1 Optical plug

The optical interface should use a duplex SC optical plug which conforms to IEC 61754-4. Rigid SC duplex connectors should not be used. Connector keys are used for transmit / receive polarity.

Alternate connectors may be used which satisfy the volumetric constraints of Figure 2.

#### 18.6.2 Optical receptacle

The SC Duplex Receptacle shall conform to the requirements of IEC 61754-4 with the following clarification:

The distance between the center lines of the active optical bores shall be 12.25/13.15mm to match the floating duplex SC optical plug.

Increasing this tolerance avoids the restrictive manufacturing tolerance associated with rigid SC connectors.

### 18.7 Copper interface

Various connectors for copper interface may be used which satisfy the volumetric constraints of Figure 2 as well as the applicable governing standards for those interfaces.

### 18.8 Module latching

#### 18.8.1 Basic requirements for latch

The XPAK specification provides basic parameters that assure that a common latch actuation technique will be presented to the end user.

#### 18.8.2 Module latching system

A rotating bail style latching method will be employed for the XPAK module. The bail will be located as part of the removable module, the latching points will be located in the module holder mounted in the host system.

The design implemented by the module manufacturer must latch to the points defined in the XPAK module holder.

The bail must rotate downward as shown in Figure 12 to unlatch the module for removal. The bail must rotate upward as shown in Figure 11 to latch the module for installation.

### 18.8.3 Module

The latching points in the module are defined in Figure 2, dimensions A1, G1, K1, and Y1.

The latch will operate within the area defined between A1 & AL1 (width); R1 Low Profile only (height)

### 18.8.4 Module holder

The latching points in the module holder are defined in Figure 5, Detail B.

**Figure 11: Module installation**

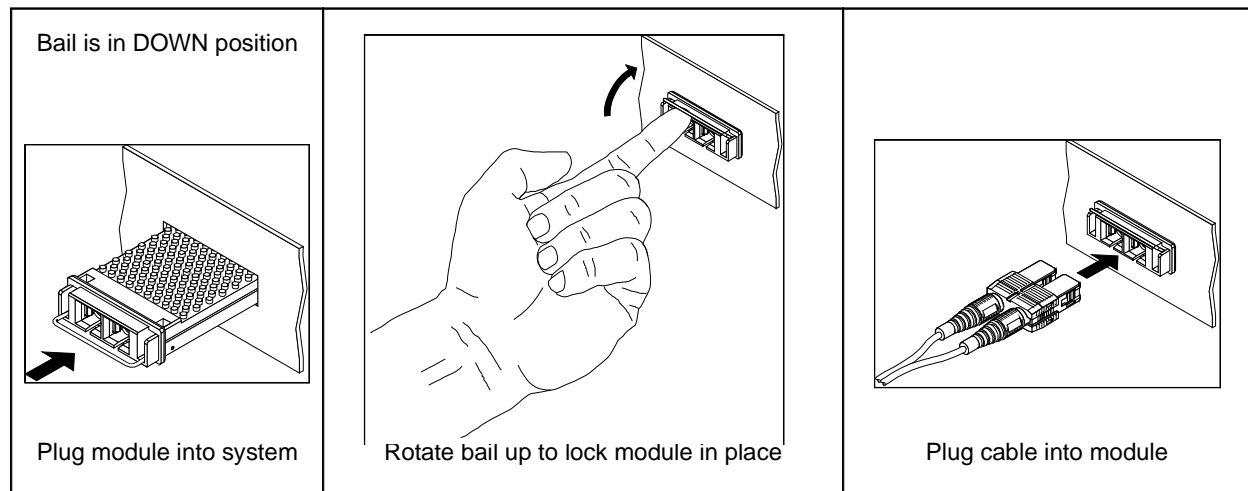

**Figure 12: Module removal**

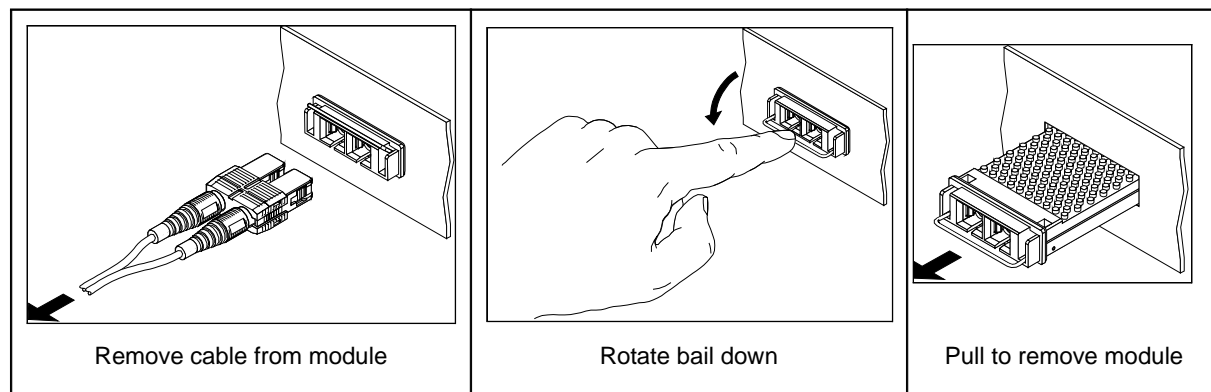

## 19 Thermal specifications

The thermal environment for characterization and measurement is specified in Section A1.

### 19.1 Maximum power dissipation

Any XPAK-compliant module will dissipate a maximum of four Watts (4W). Non-compliant modules in midboard or custom mounting and heatsinking arrangements may dissipate more than 4W.

### 19.2 Maximum case temperature

Maximum case temperature for a XPAK module is 70 degrees Celsius, measured at the position AK1 shown in Figure 2.



## 20 Electrical specifications

The electrical interface, including pinout, power supplies and management functionality, is specified by XENPAK MSA v2.1 with the exceptions listed below. The pinouts for both SFI4-P2 and XAUI implementations, identical to XENPAK MSA v2.1 are shown for reference only in

### 20.1 XPAK register set relative to XENPAK MSA v2.1

The XPAK register map is identical to XENPAK except for the following exceptions:

- The XPAK register OUI, in register 32818 (decimal) 0x8032 (hexadecimal) is 0x000ACB (hexadecimal) (this is different from XENPAK which is 0x0008BE)
- The XPAK register package type mask, in register 32768 (decimal), 0x8012 (hexadecimal) is 00000100 (binary), 4 (decimal), 0x04 (hexadecimal) (this is different from XENPAK which is 0x01)

### 20.2 XPAK XAUI pinout (identical to XENPAK v2.1 pinout)

This pinout is shown for reference only, and is identical to XENPAK v2.1.

**Table 11: XAUI pinout**

Pin No	Name	Pin No	Name
70	GND	1	GND
69	GND	2	GND
68	RESERVED	3	GND
67	RESERVED	4	5.0V
66	GND	5	3.3V
65	TX LANE3-	6	3.3V
64	TX LANE3+	7	APS
63	GND	8	APS
62	TX LANE2-	9	LASI
61	TX LANE2+	10	RESET
60	GND	11	VEND SPECIFIC
59	TX LANE1-	12	TX ON/OFF
58	TX LANE1+	13	RESERVED
57	GND	14	MOD DETECT
56	TX LANE0-	15	VEND SPECIFIC
55	TX LANE0+	16	VEND SPECIFIC
54	GND	17	MDIO
53	GND	18	MDC
52	GND	19	PRTAD4
51	RX LANE3-	20	PRTAD3
50	RX LANE3+	21	PRTAD2
49	GND	22	PRTAD1
48	RX LANE2-	23	PRTAD0
47	RX LANE2+	24	VEND SPECIFIC
46	GND	25	APS SET
45	RX LANE1-	26	RESERVED
44	RX LANE1+	27	APS SENSE
43	GND	28	APS
42	RX LANE0-	29	APS
41	RX LANE0+	30	3.3V
40	GND	31	3.3V
39	RESERVED	32	5.0V

**Table 11: XAUI pinout**

Pin No	Name	Pin No	Name
38	RESERVED	33	GND
37	GND	34	GND
36	GND	35	GND

**20.3 XPAK SFI4-P2 pinout****Table 12: SFI4-P2 pinout**

Pin No	Name	Pin No	Name
70	GND	1	GND
69	GND	2	GND
68	REF CLK-	3	GND
67	REF CLK+	4	5.0V
66	GND	5	3.3V
65	TX LANE3-	6	3.3V
64	TX LANE3+	7	APS
63	GND	8	APS
62	TX LANE2-	9	LASI
61	TX LANE2+	10	RESET
60	GND	11	VEND SPECIFIC
59	TX LANE1-	12	TX ON/OFF
58	TX LANE1+	13	TX LOCK ER#
57	GND	14	MOD DETECT
56	TX LANE0-	15	VEND SPECIFIC
55	TX LANE0+	16	VEND SPECIFIC
54	GND	17	MGMT I/F
53	GND	18	MGMT CLK
52	GND	19	MGMT Mode
51	RX LANE3-	20	PRTAD3
50	RX LANE3+	21	PRTAD2
49	GND	22	PRTAD1
48	RX LANE2-	23	PRTAD0
47	RX LANE2+	24	MODE XAUI/SFI4_P2
46	GND	25	APS SET
45	RX LANE1-	26	RX LOCK ER#
44	RX LANE1+	27	APS SENSE
43	GND	28	APS
42	RX LANE0-	29	APS
41	RX LANE0+	30	3.3V
40	GND	31	3.3V
39	SRCCLK-	32	5.0V
38	SRCCLK+	33	GND
37	GND	34	GND
36	GND	35	GND

# Appendices

# A1 Thermal testing environment

## A1.1 Thermal verification

The purpose of this section is to provide guidance to XPAK suppliers to create a consistent test environment. This will identify the limiting or boundary conditions to help efficient thermal system design when using XPAK modules.

Substantial variations in module thermal performance can occur depending on system level thermal design. As a result, XPAK sponsors and other interested end users have provided system level airflow requirements.

The parameters defined in this section shall enable clear communication of thermal simulation or thermal test data between module supplier and system vendor and will aid correlation between simulation and actual measured results.

This document however does not guarantee system level performance nor port density. This will be resolved on a system specific basis.

Any characterization results presented in this thermal section are given as examples only.

## A1.2 System design & assumptions for characterization, simulations and Measurements

Information presented by the module supplier in relation to this document should be obtained from a “confined or ducted flow” system. An example of a test chamber is shown in Figure 14.

Each application shown in Figure 16 through Figure 20 has unique physical design characteristics that affect air flow over the XPAK module. These characteristics are system dependent and are not described nor defined in this specification. The airflow velocities, inlet temperature, etc noted in Table 8 are based on input from sponsors and other end users as previously noted. Therefore, the airflow in the test chambers is to be directed as noted in Figure 16 through Figure 20. Modules must meet the thermal requirements noted in Table 8.

Airflow should be characterized using a calibrated hot wire anemometer placed at the airflow inlet.

Airflow measurement points are shown in Figure 15.

Thermocouples should be used to measure case temperature at the worst case location on a given design.

Each module vendor as a minimum requirement should provide measurement data, defined as recommended in Table 8.

It is expected that identical PMD types will be characterized for a given test. (for example, mixing 850nm PMD's with 1310nm PMD's within a given test would not be typical).

Groups of 1, 2, 4, and 8 modules will be tested in 1U Switch “like” environments.

A single module will also be tested in PCI card & cPCI/Switch Blade “like” environments.

Figure 16 through Figure 20 provide the air flow direction to be used in each of the aforementioned environments. Table 8 provides additional air flow requirements.

When undergoing thermal evaluation, XPAK transceivers should output idle patterns on both the electrical and optical outputs.

Other measurement data provided is at the discretion of the supplier.

### A1.2.1 Test environment

- The system shall provide uniform airflow across the vent opening and be of constant volume airflow.
- Altitude (sea level)
- Air humidity (50% +/- 10)
- Inlet air temperature (+25 deg C to +60 deg C)
- Minimum range of airflows (100 – 300 lfm)

### A1.2.2 Test Fixture

- A test fixture reference design is shown in Figure 14.
- A wind tunnel with poor thermal conduction will be used – a plastic (IR transparent to allow for the potential use of an infrared camera) is recommended.
- There are no slots in the system PCB.
- Module holders will be installed in all locations.

- Modules under test will be installed adjacent to one another with no gaps from empty module holder positions.
- Dummy modules will be installed in all locations not under test to close the opening(s) in the system faceplate.
- For the multiple module configurations it is assumed that the conditions drawn for module 1 will be duplicated for module “n”.
- The test chamber will be clear of obstruction for 30cm after the outlet.

### A1.2.3 Module conditions

- A steady state should be obtained to take the measurements.

### A1.2.4 Temperature measurement position

- The temperature should be measured at the worst case location on a module for a given design when measured under the conditions defined in this section. This point can be at any location on the module and for the purposes of this MSA will be referred to as reference point AK1. The results formats suggested refer to this worst case position.

### A1.2.5 Optional airflow measurement points

- To aid correlation of vendor simulation to vendor system test data, optional test points for airflow measurement have been defined in close proximity to the module.

### A1.2.6 Example data

- Example data collected according to Section A1.2.4 will be represented in a chart as described in Table 8.
- Case temperature of the hottest module within a multiple or single module configuration will conform to IEC 60950.

### A1.2.7 Test chamber

A test chamber is defined in Figure 13, Figure 14, Figure 15 and Table 7.

**Figure 13: Test chamber cross-section**

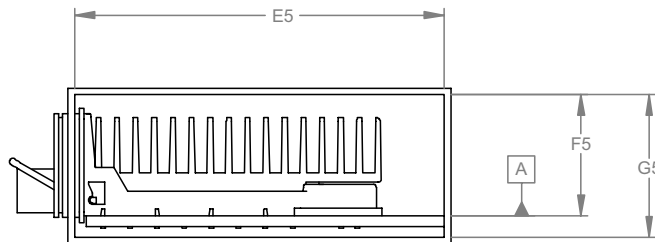

**Table 7 Thermal test environment dimensions**

Item	Dimensions		Tolerances +/-		Comments
	MM	[IN]	MM	[IN]	
A5	19.05	.750	2.00	.079	Distance from module flange to optional airflow test point TP2
B5	57.15	2.250	2.00	.079	Distance from module flange to optional airflow test point TP3
C5	4.22	.166	0.50	.020	Distance from edge of module to optional airflow test points
D5	2.03	.080	2.00	.079	Distance from top of module to optional airflow test points
E5	86.61	3.410	1.00	.039	Inside width of wind tunnel
F5	28.27	1.113	1.00	.039	Location of PWA from top of wind tunnel
G5	33.35	1.313	1.00	.039	Height of wind tunnel
H5	304.80	12.000	1.00	.039	Spacing for airflow measurement point PT1
I5					Not used
J5	31.12	1.225	1.00	.039	Module C/L to edge of PWA
K5	41.91	1.650	Basic	Basic	Pitch between modules
L5	304.80	12.000			Minimum length of outlet chamber

Figure 14: Test chamber

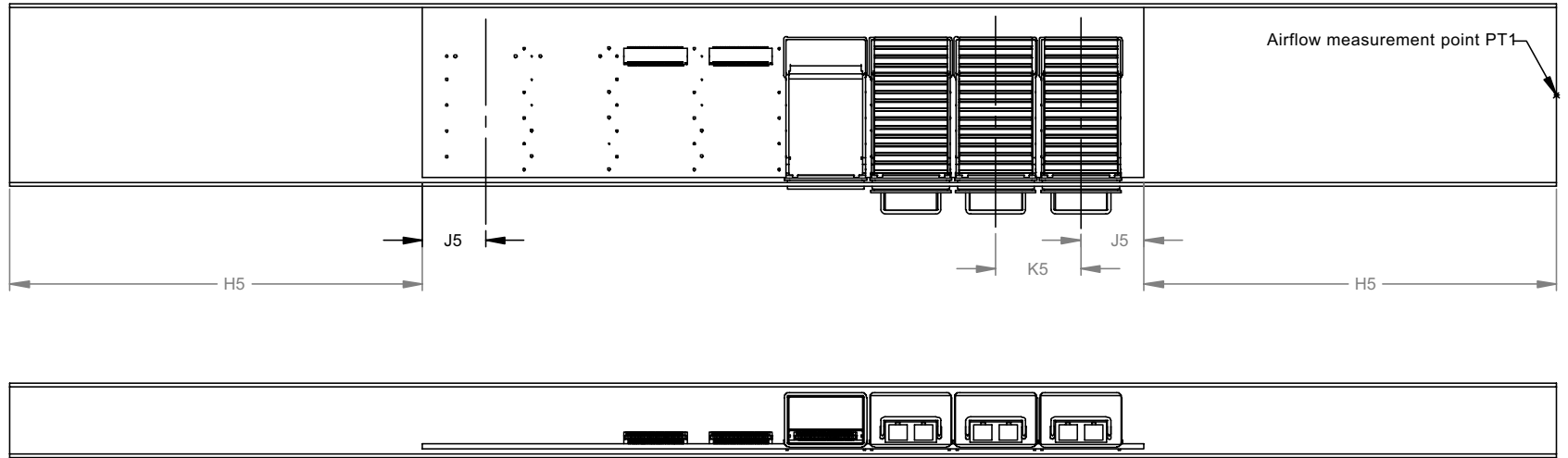

**Figure 15: Airflow measurement points**

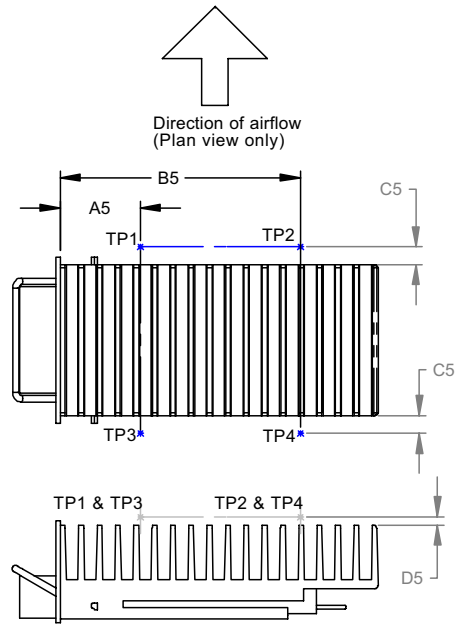

Figure 16: Front to Back Air Flow in Rack Enclosures

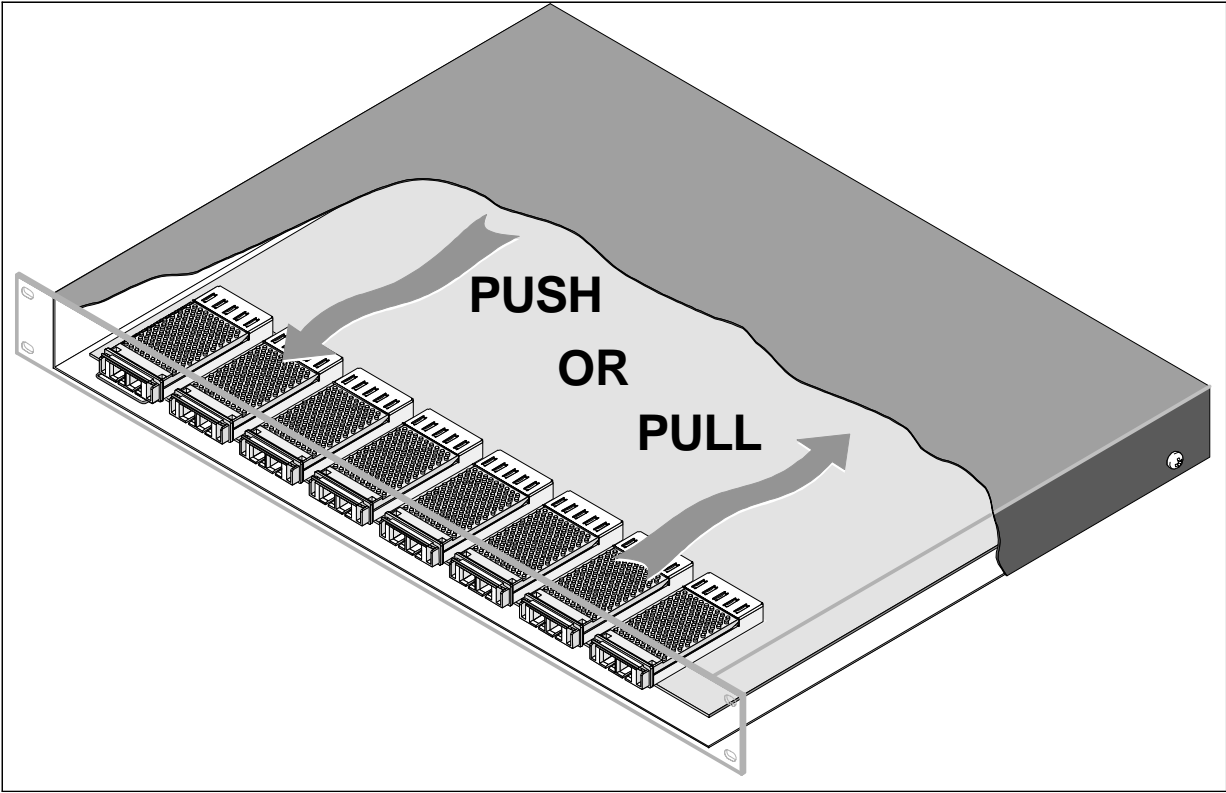
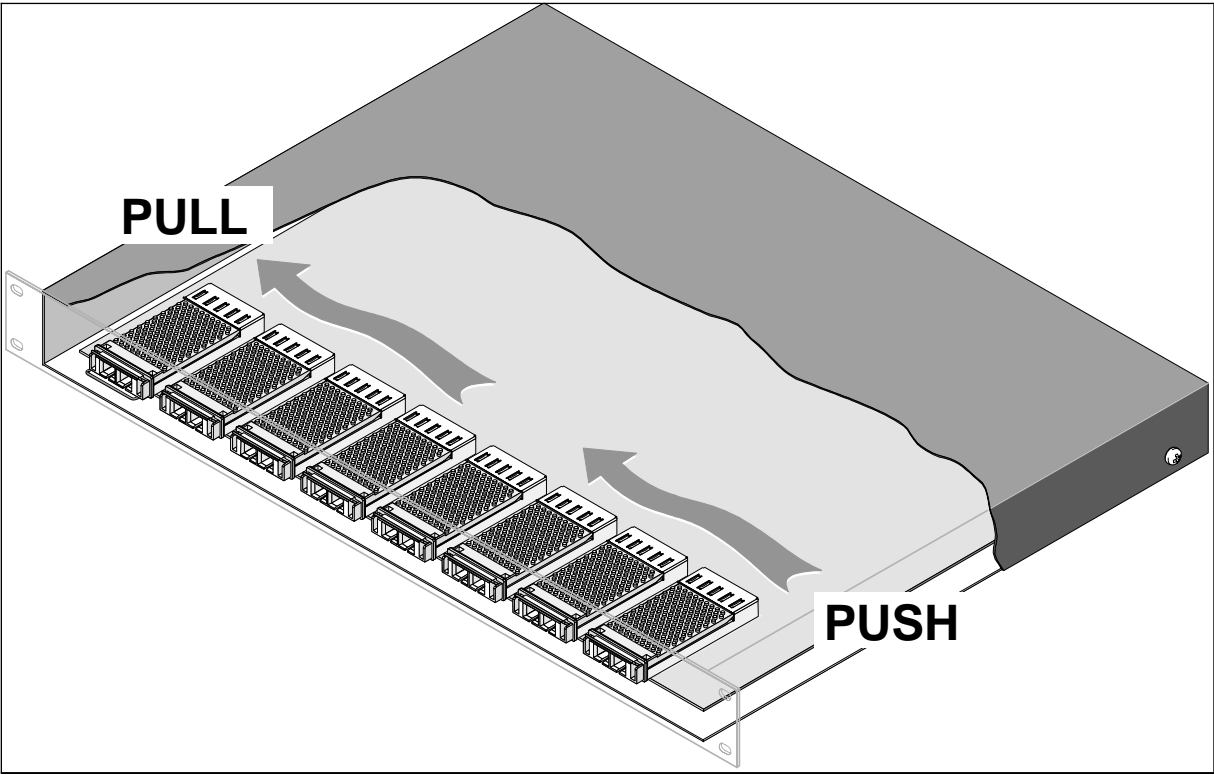
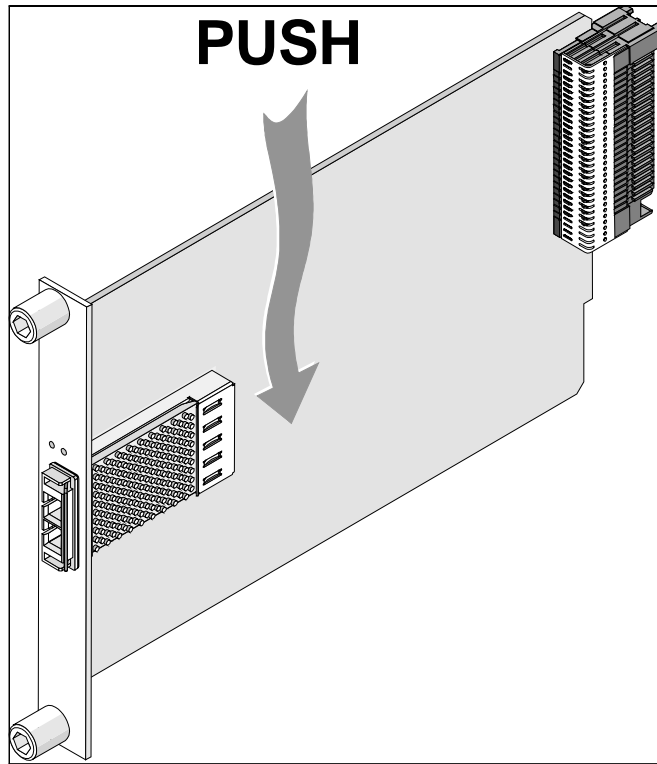

Figure 17: Side to Side Air Flow in Rack Enclosures

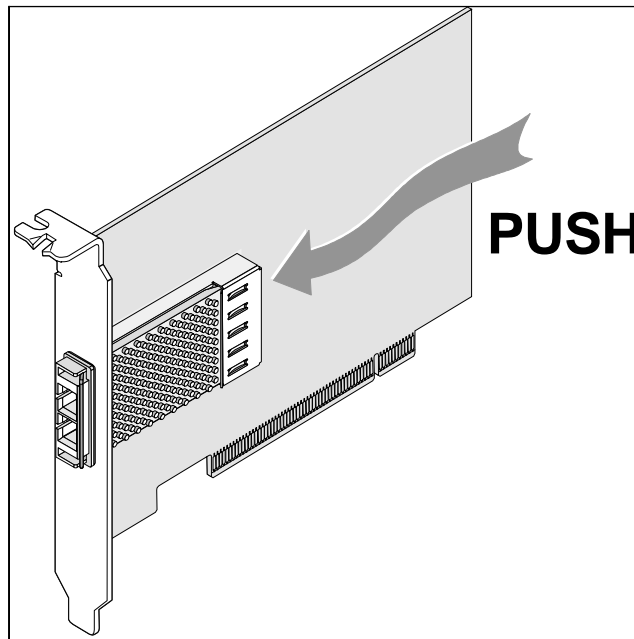



**Figure 18: Air Flow on Switch/Server/cPCI Blades**



**Figure 19: Air Flow on Horizontal & Vertical PCI Card Cards**



**Figure 20: Air Flow in InfiniBand HCA/TCA Carriers**

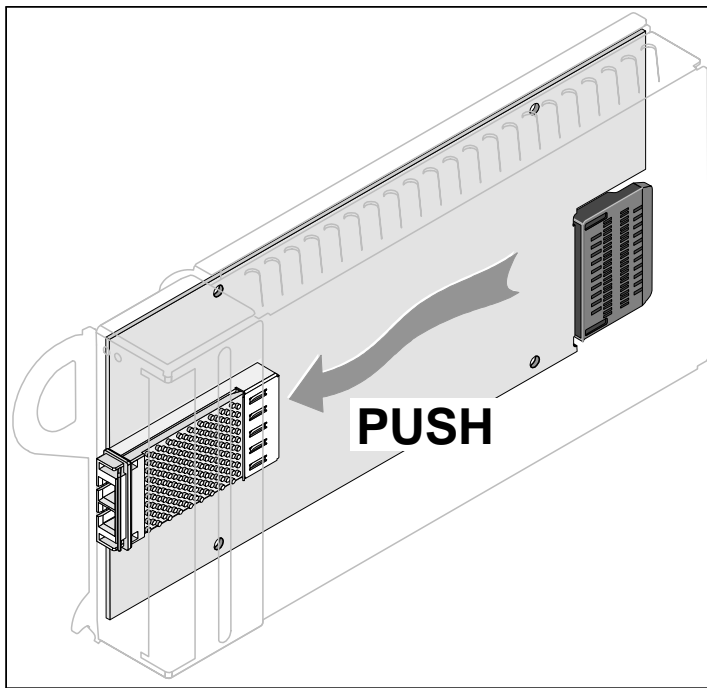
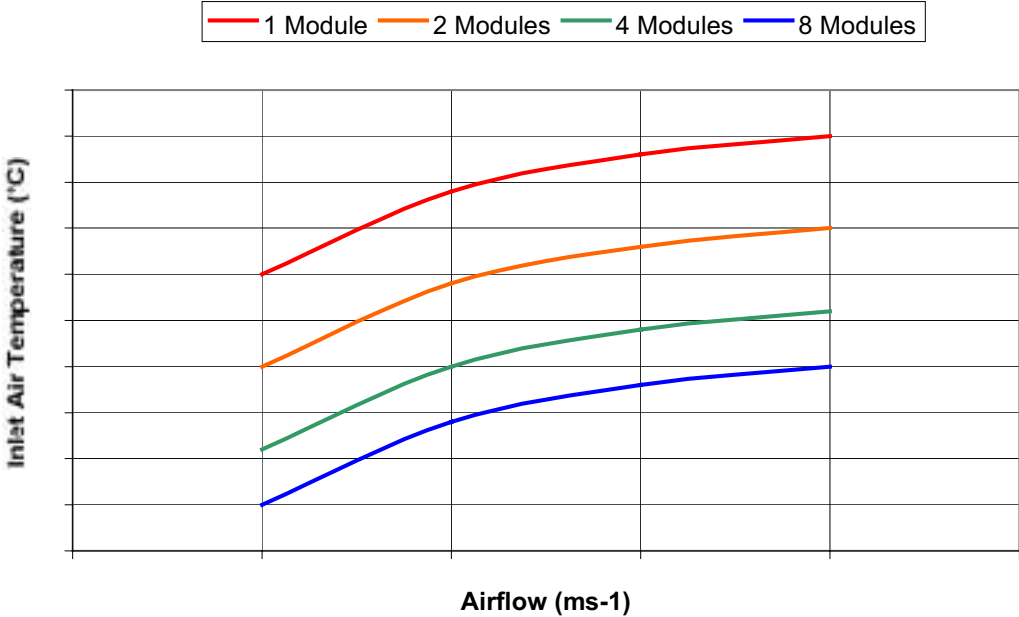

**Table 8 Thermal data table (at minimum airflow)**

	<b>Module Spacing</b>	<b>Max Air Inlet temperature</b>	<b>Test Point A1</b>	<b>Air Flow Point A2</b>	<b>Air Flow Point A2</b>
Side/Side (1) Module			100		
Side/Side (2) Modules			300		
Side/Side (4) Modules			300		
Side/Side (8) Modules			300		
Front/back (1) Module			100		

- Module suppliers to test to all applicable environments for their module – must test one environment minimum.

**Figure 21: Inlet air temperature vs. airflow**



## **A2 Flangeless module holder**

The following optional module holder is for the use of customers with limited internal chassis clearance (height or headroom).

### **A2.1 Flangeless module holder dimensions**

Dimensions and datums for Figure 22 and Figure 23 are listed in Table 1 on page 16, Table 2 on page 16, Table 3 on page 18 and Table 4 on page 21.



**Figure 23: Flangeless module holder**

